

NEUTER OR SPAY KIT COMING SOON ■ MAILBOX IMPROVEMENT WEEK

POSTAL BULLETIN

PUBLISHED SINCE MARCH 4, 1880

PB 22076, MAY 16, 2002



HEROES OF 2001

FIRST-DAY-OF-ISSUE
JUNE 7

PUBLICITY KIT INSIDE

CONTENTS

The *Postal Bulletin* is also available on the World Wide Web at <http://www.usps.com/cpim/ftp/bulletin/pb.htm> for customers and at <http://blue.usps.gov> for employees.

Letter From Postmaster General 3
Letter From Vice President 4
Publicity Kit: Heroes of 2001 Semipostal Stamp 5

Administrative Services
 ASM Revision: Photo Identification Requirements 19
 Handbook Revision/Ordering Instructions: Handbook AS-805, *Information Security* 20

Child Alert Program
 Missing Children Posters 21

Customer Relations
 Mail Alert 25
 All Offices With City Motorized, Rural, and Highway Contract Box Delivery Routes: Mailbox Improvement Week, May 20–25 25
 The Graceful Envelope Contest 39

Domestic Mail
 Reminder: R2001-1 PAVE Cycle F Testing and Certification 41
 District Marketing and Finance Managers: Express Mail Corporate Account (EMCA) — Negative Account Balances 42
 Customer Ordering Instructions: Postal Service Zone Charts 42
 APO/FPO Changes 45
 Overseas Military Mail 45

Memorial Day Posters 57
Independence Day Posters 59

Fraud Alert
 Foreign Order No. 461 63
 Withholding of Mail Orders 63
 Invalid Express Mail Corporate Account Numbers 64
 Missing, Lost, or Stolen U.S. Money Order Forms 67
 Missing, Lost, or Stolen Canadian Money Order Forms 72
 Counterfeit Canadian Money Order Forms 74
 800 Number Available to Verify Canadian Money Orders 74

International Mail
 ICM Updates: International Customized Mail 75

Philately
 Stamp Announcement 02-10: *Star* Definitive Stamp 83
 Stamp Announcement 02-11: *U.S. Flag* Definitive Stamp 86
 Stamp Announcement 02-12: *U.S. Flag* Nondenominated Definitive Stamp 94

Stamp Announcement 02-13: *Antique Toys* Stamps 101
 Stamp Announcement 02-14: *Masters of American Photography* Stamps 103
 Stamp Announcement 02-15: *Ribbon Star* Stamped Envelope 105
 Stamp Announcement 02-16: *Carlsbad Caverns National Park* Stamped Card 109
 Stamp Announcement 02-17: *Heroes of 2001* Semipostal Stamp 112
 Revision: 2002 Stamps and Postal Stationery — Announcement 02-C (May 2002) 114
 Pictorial Cancellations Announcement 117
 Special Cancellation Die Hubs 125

Post Offices
 Post Office Changes 126

Postal Employees
 New Performance Tool: LEAD — Leadership Excellence at the Desktop 128
 Handbook EL-806 Revision: Seizures/Epilepsy — New-Hire Applicants 129
 USPS–APWU National Agreement: Changes to Regular Uniform and Work Clothes Programs Allowances 2000–2003 129
 Reminder: MI EL 410-2002-1, *Process for Completing EAS Merit Performance Evaluations and Setting Objectives* 130
 Thrift Savings Plan Fact Sheet 131

Retail
 Field Notification: E-Mail Notification for Resetting Electronic Manually Reset Meters 133

Postal Bulletin Distribution 134

Postal Bulletin Index
 2001 Annual Index PB 22067 (1-10-02)



The *Postal Bulletin* is published biweekly; information is effective for one year unless it changes a permanent directive or unless otherwise specified.



Ordering Information: Following is the list of postal stock numbers (PSNs) to use when ordering copies of the *Postal Bulletin* from the MDC:

PB 22076 7690-05-000-4841	PB 22069: 7690-05-000-4834	PB 22062: 7690-04-000-5669	PB 22055: 7690-04-000-5662
PB 22075 7690-05-000-4840	PB 22068: 7690-04-000-5675	PB 22061: 7690-04-000-5668	PB 22054: 7690-04-000-5661
PB 22074 7690-05-000-4839	PB 22067: 7690-04-000-5674	PB 22060: 7690-04-000-5667	PB 22053: 7690-04-000-5660
PB 22073 7690-05-000-4838	PB 22066: 7690-04-000-5673	PB 22059: 7690-04-000-5666	PB 22052: 7690-04-000-5659
PB 22072: 7690-05-000-4837	PB 22065: 7690-04-000-5672	PB 22058: 7690-04-000-5665	PB 22051: 7690-04-000-5658
PB 22071: 7690-05-000-4836	PB 22064: 7690-04-000-5671	PB 22057: 7690-04-000-5664	PB 22050: 7690-04-000-5657
PB 22070: 7690-05-000-4835	PB 22063: 7690-04-000-5670	PB 22056: 7690-04-000-5663	

JOHN E. POTTER
POSTMASTER GENERAL, CEO



May 2002

Dear Fellow Postal Employee:

I am proud to announce the start of our 2002 U.S. Savings Bonds Campaign which runs from May 13 through June 7, 2002. The Savings Bonds Campaign is your chance to learn about U.S. Savings Bonds and to sign up for payroll deduction. For those of you who already participate, you can take this opportunity to review your financial plans, adjust your allotments, and add the Series I Bonds to your deductions.

This year we are offering both the Series EE and Series I Bonds through payroll deduction. The Series EE Savings Bond offers market-based interest rates. Payroll deduction for the Series EE Bonds will begin within two pay periods.

The inflation-indexed I Bond earns an adjustable interest rate that keeps your savings growing over and above inflation for up to 30 years. This means a rising cost of living will not erode your purchasing power. Requests for payroll deduction for the Series I Bonds will be taken during the Campaign period and held for processing later this year.

Earnings from U.S. Savings Bonds are exempt from local and state income taxes. Federal income taxes are deferred until you choose to redeem them, or your U.S. Savings Bonds stop earning interest at 30 years. You may even be able to avoid federal income taxes if you use your earnings to pay for qualified higher education expenses. This could be a very important feature for those of you with young families.

Enclosed are the following items: the U.S. Savings Bonds Program Brochure, the Series EE deduction card, the Series I deduction card, and a return envelope. Simply complete the appropriate deduction card(s), and return the card(s) in the prepaid envelope before June 7. Payroll deductions for Series EE Bonds will begin within two pay periods. Requests for Series I Bonds will be held for processing and payroll deductions will begin later this year. We will notify you before the effective date of the Series I Bond deduction.

You can get more savings bond information on the Internet at www.savingsbonds.gov or by calling 1-888-588-BOND. Now is the time to invest in your future and to invest in America.

Sincerely,

A handwritten signature in black ink that reads "John E. Potter".

John E. Potter

475 L'ENFANT PLAZA SW
WASHINGTON DC 20260-0010
www.usps.com

AZEEZALY S. JAFFER
VICE PRESIDENT, PUBLIC AFFAIRS AND COMMUNICATIONS



May 2002

DISTRICT MANAGERS
POSTMASTERS

SUBJECT: *Heroes of 2001* Semipostal Stamp Ceremonies

Community Relations has prepared the enclosed publicity kit to assist you in planning local events for the upcoming *Heroes of 2001* semipostal stamp to be issued in New York.

This new stamp provides an excellent opportunity for us to say thank-you to the heroes who live and work in our communities. Ceremonies surrounding the issuance of the stamp will serve as a forum for our customers and civic leaders to participate in discussions on present and future challenges facing the Postal Service.

As you begin planning your activities to pay tribute to the men and women who are our everyday heroes, also plan on highlighting the vital role the Postal Service has played, and continues to play, in binding this nation together. Explain to your audiences how we look forward to working with our employees, our customers, and civic leaders to define the Postal Service of the future and to ensure that the American people continue to receive the best postal service in the world.

The enclosed publicity kit provides a step-by-step guide to help you plan your stamp ceremonies. The kit includes:

- Suggestions to generate publicity
- How to obtain stamp artwork
- Pictorial cancellation artwork
- Licensing restrictions
- Questions and answers
- IRS exemption letter
- Fill-in news release for the *Heroes of 2001* semipostal stamp
- Sample media advisory
- Service talk for employees
- Advertising plan

Please use these materials to publicize your *Heroes of 2001* stamp ceremonies, and be sure to keep your Area Public Affairs and Communications Manager informed of your activities.

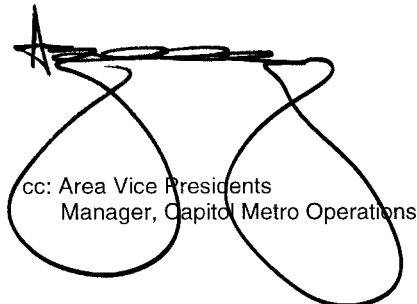

cc: Area Vice Presidents
Manager, Capitol Metro Operations

475 L'ENFANT PLAZA SW
WASHINGTON DC 20260-3100
202-268-2143
FAX: 202-268-3524

*PUBLICITY KIT***Heroes of 2001 Semipostal Stamp****Events and Publicity**

On June 7, 2002, the U.S. Postal Service will issue the *Heroes of 2001* semipostal stamp. The stamp will go on sale nationwide that day. This new stamp is expected to remain on sale through December 31, 2004, and will be sold for 45 cents. All sales of this semipostal stamp must be recorded in **AIC 087**. The difference between the sales price and the underlying First-Class Mail® rate constitutes a contribution to provide assistance to the families of the emergency relief personnel killed or permanently disabled in the line of duty in connection with terrorist attacks on September 11, 2001. It is the second semipostal stamp the Postal Service has issued — the first being the *Breast Cancer Research* semipostal stamp that remains on sale until December 31, 2003.

Public Law #107-67 requires that funds raised from the sale of the *Heroes of 2001* semipostal stamp (net of the Postal Service's reasonable costs) be transferred to the Federal Emergency Management Agency (FEMA) to provide assistance to the families of the emergency relief personnel killed or permanently disabled in connection with the terrorist attacks of September 11, 2001.

There are many ways to generate local interest in this very special *Heroes of 2001* stamp. Following are some methods to capture customer and media attention.

Stage a Kick-Off Event

Invite employees, local firefighters, emergency medical technicians (EMTs), law enforcement personnel, local politicians, chamber of commerce members, and others to make public purchases of the *Heroes of 2001* stamp and to mail letters using the stamp.

Other Event Ideas

(Remember, when planning events, make sure stamps are available.)

- Develop a "Celebration of Life," "Remembrance," or "Heroes" wall at your Post Office and invite EMTs, law enforcement people, firefighters, and/or family members to display a red, white, and blue ribbon in honor of our heroes.
- Plan an event at the local fire or police station or other public location and include a display of an enlargement of the new stamp. Invite appropriate speakers and/or present special awards to a local hero or heroes.
- Present a framed enlargement of the new stamp to your local fire, EMT, or police department.
- The Postal Service employs approximately 800,000 people, many of whom donate their time as EMTs, National Guardsmen, or volunteer firefighters. Recognize your local postal "heroes" at ceremonies. Ask Congressional, civic, and community leaders to participate.
- Hold ceremonies to welcome home the men and women of your community who served in Afghanistan.
- Coordinate groups of children — children of postal employees, YMCA camps, Boy Scout and Girl Scout troops, etc., to write thank-you letters or notes to local police, EMTs, or firefighters. Have the children place the *Heroes of 2001* semipostal stamps on their letters and drop them in the mailbox at the Post Office. (Photo opportunity.)
- Coordinate an essay-writing contest or art contest for children using the *Heroes of 2001* theme. Get local newspaper editors to judge essays and select winners. Have local art teachers from community schools judge art entries. Invite winners of those contests to your ceremonies, recognize their work, and present them with a sheet of stamps or philatelic collectible. Display their work in your lobby.

Implement any of these ideas, or brainstorm with your employees to come up with ideas of your own. Using the publicity materials in this kit, be sure to publicize each and every event to your local newspaper, radio stations, and television stations. Send a letter or press release, and then follow up with a phone call.

Suggested Participating Organizations

Local FEMA Offices
 FEMA Headquarters
 202-646-2500
www.fema.gov

US Fire Administration (part of FEMA)
www.fema.gov (click on *US Fire Admin.*)

FRATERNAL ORDER OF POLICE ASSOCIATES
 PO BOX 9124
 WARWICK RI 02889-0124
 401-738-1525
www.grandlodgefop.org

INTERNATIONAL ASSOCIATION OF FIREFIGHTERS
DEPARTMENT OF PUBLIC RELATIONS AND
COMMUNICATIONS
1750 NEW YORK AVENUE NW
WASHINGTON DC 20006-5395
www.iaff.org

INTERNATIONAL ASSOCIATION OF FIRE CHIEFS
4025 FAIR RIDGE DRIVE
FAIRFAX VA 22033-2868
703-273-0911
www.iafc.org

Stamp Artwork

To obtain stamp artwork, including color transparencies and enlargements, contact:

DODGE COLOR
4827 RUGBY AVE STE 100
BETHESDA MD 20814-3028
301-656-0025

Please plan ahead and allow enough time for production and shipping.

Important Reminders

Funds from the sale of the *Heroes of 2001* semipostal stamp will be used to provide assistance to the families of the emergency relief personnel who were killed or became permanently disabled in the line of duty in connection with the September 11, 2001, terrorist attacks.

All sales for the *Heroes of 2001* stamp must be recorded in AIC 087.

Event Planning Checklist

When planning *Heroes of 2001* stamp events, keep the following suggestions in mind:

- Begin planning immediately.
- Set a date.
- Secure participants (business customers, postal employees who are heroes or have a tie to the tragedy, local politicians, celebrities, etc.).
- Order enlargements of the stamp image, flyers, and other supplies for the event.
- Prepare the special pictorial cancellation provided in this kit.
- Secure staging and sound equipment, if applicable.

- Plan signage, including a podium sign and banners.
- Launch a local publicity campaign using the materials in this kit.
- Draft a sequence-of-events agenda and speaker remarks.
- Plan retail opportunities encouraging sales of the stamp.
- Prepare ceremony programs and invitations, if applicable.
- Send news clippings to your area Public Affairs and Communications manager.

Heroes of 2001 Stamp Pictorial Cancellation

The Postal Service has authorized one pictorial cancellation design for field use to help spread awareness about the *Heroes of 2001* semipostal stamp. Post Offices planning events are encouraged to use the design depicted below. Offices can offer this cancellation through mail-back service for 30 days.

As a reminder, the Postal Service must endeavor to make all unusual postmarking services widely known to collectors through advance publicity to avoid limiting the availability of these postmarks. Therefore, all pictorial cancellations must be reported to Stamp Services before local events. *Please use the announcement form on page 17 to report your use of the cancellation.*

Guidelines for Finalizing Heroes of 2001 Station Pictorial Cancellation Art

To finalize the *Heroes of 2001* Station pictorial cancellation art (see below), insert the date and the city, state, and ZIP Code of the physical location of your event within the postmark circle. Overall dimensions of the pictorial cancellation must not exceed 4 inches horizontally by 2 inches vertically. Collectors prefer the dimensions 3 1/2 inches by 1 inch.





Company	Contact	Address	City, State, ZIP Code	Telephone	Fax
Financial Innovations*	Mark Weiner	1 Weingeroff Boulevard	Cranston, RI 02910	401-467-3178	401-467-3570
Ipromoteu.com	Pat Caccamo	8 Strathmore Road	Natick, MA 01760	877-470-1436	905-542-9454
Jonathan Grey and Assoc.	Mario Rodriguez, Michelle Hagerty	920 Calle Negocio, Suite B	San Clemente, CA 92673	949-498-2515	949-298-2830
March Co.	Doug March	3815 Academy Parkway, N/NE	Albuquerque, NM 87109-4408	505-345-2521	505-345-0407
Sonoma Pins	Bernard Friedman	677 First Street W	Sonoma, CA 95467-7003	707-996-9956	707-996-9957
Winco	Andy Boston, Bryan Fougner	9019 Oso Avenue, Suite F	Chatsworth, CA 01311-4117	818-718-1191	818-700-9778
US Allegiance	Steve Crawford, Jennifer Houston	63007 Layton Avenue	Bend, OR 97701-3735	541-330-6282	541-330-6268

* Agreement not yet fully executed.

Licensing: Heroes of 2001 Pins for Sale

Use of the *Heroes of 2001* stamp image remains highly restricted. The Postal Service has now been granted the right to use the image on pins for Postal premiums.

The pins are not for resale.

You can order the pins using authorized Postal Service purchase methods from the following list of official licensees. If you have any questions on pricing, quantity, and so forth, please directly contact the companies listed at the top of this page.

If you have any questions on how to obtain other officially licensed Postal Service products, please contact Tiffani St.Cloud at 202-268-8116 or send an e-mail to licensing@usps.com.

Questions and Answers

How many Heroes of 2001 stamps will be printed?

The Postal Service will print 205 million self-adhesive *Heroes of 2001* stamps.

How is this stamp different from other postage stamps?

The *Heroes of 2001* stamp, also referred to as a "semi-postal," is the second U.S. stamp in history to have its net proceeds above postage (and the Postal Service's reasonable costs) earmarked for a specified cause. The first semi-postal was issued as a result of legislation enacted in 1997 to benefit breast cancer research.

Why is a semipostal stamp being issued to provide assistance for families of emergency relief personnel killed or permanently disabled in connection with terrorist attacks of September 11, 2001?

Public Law #107-67 directs the Postal Service to issue the stamp. The legislation instructs the Postal Service to transfer the funds available from the sale of the semipostal to FEMA.

How much does the Heroes of 2001 stamp cost?

The price of the *Heroes of 2001* stamp is 45 cents and is valid for postage in the amount of the First-Class Mail single-piece, first-ounce letter rate in effect at the time of purchase, which is currently 34 cents. The difference between the price of the stamp and the First-Class Mail postage rate (minus Postal Service costs) will be transferred to FEMA.

Who receives the money?

Funds will be transferred to FEMA to provide assistance to the families of emergency relief personnel killed or permanently disabled in the line of duty in connection with the terrorist attacks of September 11, 2001.

Who designed the Heroes of 2001 Stamp?

The art director is Derry Noyes. The photograph is by Thomas E. Franklin of the *Bergen Record* newspaper.

Has the Postal Service issued other stamps to promote social or health-related causes?

Yes. For six decades, the Postal Service has issued new stamps to help raise awareness of a variety of health and social issues including prostate cancer awareness, organ and tissue donation, hospice care, drug abuse, AIDS awareness, and environmental conservation. However, none of those were semipostal stamps.

Where will the stamp be available for sale?

The *Heroes of 2001* stamp may be purchased at Post Offices, in vending machines in postal and non-postal locations, by calling toll-free 800-STAMP-24, and by accessing the Postal Service Web site at www.usps.com.

When does the stamp go off sale?

The stamp may remain on sale no later than December 31, 2004.

Service Talk

The Postal Service, through its commemorative stamp program, has a long history of promoting awareness about a multitude of social causes that affect people throughout the United States and around the world.

On July 29, 1998, we issued our nation's first semipostal stamp, the *Breast Cancer Research* stamp, which is scheduled to be sold through December 31, 2003.

The *Heroes of 2001* stamp was developed to provide assistance for families of emergency relief personnel killed or permanently disabled in the line of duty in connection with the terrorist attacks of September 11, 2001. We recommend that you bring these stamps to your customers' attention and ask them to consider purchasing the *Heroes of 2001* stamp to use on their mailings.

To review, here's how sales must be handled:

- The Postal Service must track the exact number of stamps sold. The *Heroes of 2001* stamp must be sold for 45 cents under **AIC 087**. The *Breast Cancer Research* stamp will continue to be reported in its separate AIC number.
- The stamp is valid for postage equal to the First-Class Mail first-ounce letter rate in effect at the time of purchase. Customers may have to be reminded that the stamp is good for 34 cents postage, not 45 cents. The difference consists of a tax-deductible contribution.
- Every Post Office must have *Heroes of 2001* stamps available for sale. Each person responsible for ordering and maintaining stamp stock must make certain their office has adequate supplies of these stamps.
- If your customers indicate they want this stamp but do not want to pay the purchase price (45 cents), please remind them that the Postal Service must, by law, collect the extra amount above postage. Use of semipostal stamps is voluntary. Offer your customer an alternative stamp to purchase if they elect not to make a contribution.
- Advise customers interested in donating without buying the stamp that they can do so through local or national charitable organizations.
- Give all customers a receipt. For retail offices that cannot provide the customer with a POS ONE or IRT receipt, use PS Form 1096, *Receipt* (see page 10).
- This self-adhesive stamp can be sold individually over the counter. Each pane has been specifically die-cut for that purpose.

- **Vending Packets:** Effective May 29, 2002, the *Heroes of 2001* stamp vending packet, Item 367400, will be released for sale, will be priced at \$4.50, and will be sold from vend "D3" (168 vends) in all multi-commodity machines in service, specifically the PCM-1625A and PCM-1625B. This stamp will remain on sale through December 31, 2004. Product identifiers have been created and can be downloaded from the Self Service web site at <http://retail.usps.gov/html/programs/selfservice.html>. Each packet will contain 10 *Heroes of 2001* semipostal stamps, one PS Form 1096, and one sheet of instructions for completing PS Form 1096.

Thank you for your help in promoting the *Heroes of 2001* stamp with our customers.

Retail Information — Postal Store

The *Heroes of 2001* stamp, as well as future *Breast Cancer Research* semipostal stamps, will be packaged for postal stores on a new specific "semipostal" backer card. A receipt form will be printed directly on the backer card with instructions on how to correctly compute the tax-deductible portion of this purchase. An automatic distribution of the *Heroes of 2001* stamp will be made to the postal stores as well as to the stamp distribution offices (SDOs). This stamp will be available for reorder from Minnesota Diversified Industries (MDI) by the SDOs and the Albuquerque postal stores. Distribution of this stamp will not be made to SDOs until first day of issue date is announced.

Taxpayers who purchase a *Heroes of 2001* semipostal stamp from the Postal Service are entitled to treat as a charitable contribution the difference between the price of the *Heroes of 2001* stamp, and the price of regular First-Class Mail postage. All sales of the *Heroes of 2001* stamp must be tracked under **AIC 087**.

Cash Receipts: Postage and Fees Refunds for Semipostal Stamps

Customers may exchange or convert semipostal stamps for their postage value (i.e., the price of the stamps less the contribution amount) to the extent that exchange or conversion of postage stamps is permitted under *Domestic Mail Manual* P014, Refunds and Exchanges. The postage the customer exchanges or converts is equal to the First-Class Mail single-piece rate in effect at the time of exchange. However, if the customer provides a receipt showing the date of purchase, the postage exchanged or converted is equal to the First-Class Mail single-piece rate in effect at the time of purchase. The contribution amount is not

refundable and is not included in the exchange or conversion value.

POS

All sales of the *Heroes of 2001* semipostal stamp must be tracked under **AIC 087**.

Vending Packets

Effective June 7, 2002, the *Heroes of 2001* stamp vending packet, Item 367400, will be priced at \$4.50 and will be sold from vend D3 (168 vends) in all multi-commodity machines in service, specifically the PCM-1625A and PCM-1625B. Product identifiers have been created and can be downloaded from the Self Service web site at <http://retail.usps.gov/html/programs/selfservice.html>. Each packet will contain 10 *Heroes of 2001* semipostal stamps, one PS Form 1096, *Receipt*, and one sheet of instructions for completing PS Form 1096.

Letter From Department of the Treasury

The letter on page 11 is from the Internal Revenue Service. It explains that the difference between the price of the *Heroes of 2001* semipostal stamp and the price of regular First-Class Mail postage will be treated as a tax-deductible charitable contribution.

Advertising Plan

In order to maximize awareness of the *Heroes of 2001* stamp, the Postal Service has developed an advertising and promotional plan to support the issuance of this stamp. This plan uses national, local, and retail initiatives to create awareness and to generate sales of the stamp.

National advertising initiatives include placing print ads in *Parade*, *USA Weekend*, and *USA Today*. Other initiatives include placing local print ads in *The New York Times*, *The Washington Post*, *Smithsonian Museum Guide*, *The Hill*, *Roll Call*, *CQ Weekly*, *Federal Times*, and *Stars and Stripes*. All of the elements will include the stamp design, description of the program, and a call to action for consumers to purchase the *Heroes of 2001* stamp at their local Post Office or by calling 800-STAMP-24.

Retail

Post Offices will receive the following in-store messaging components to support the issuance of the *Heroes of 2001* semipostal stamp in early June. They are a lobby poster and a counter easel with take-one brochure.

The poster, counter easel, and take-one brochures will be shipped directly to Post Offices along with specific placement instructions.



Semipostal Fundraising Stamp

Purchase stamps online at www.usps.com/shop or also available in Postal stamp vending machines.

DID YOU KNOW

a portion of the purchase price for a **semipostal stamp is tax deductible**? Details are inside.

The difference between the purchase price of this product and the First-Class first-ounce rate at the time of purchase is tax-deductible.

Use this form at tax time.

UNITED STATES POSTAL SERVICE[®] Receipt

Amount (Written Out) /100 Dollars Amount (in Numbers) \$

Purpose:

Is any Portion of this Sale a Charitable Tax Deduction?
 Yes No

If "Yes," the fair market value of the postage portion of the foregoing stamps equals the First-Class postage rate.

By (Signature and Title) Date

PS Form 1096, April 1999

Figuring the tax-deductible portion of this purchase is easy.

- A** Total amount of semipostal stamp purchase (e.g., 20 stamps @ \$ purchase price)
- B** Total First-Class rate at the time of purchase multiplied by the number of stamps purchased (e.g., 20 stamps x \$ First-Class rate). This is the "fair market value*" of the stamps.
- C** Total purchase amount (A) minus "fair market value" (B) = Tax Deductible

UNITED STATES POSTAL SERVICE[®] Receipt

Amount (Written Out) [A] /100 Dollars Amount (in Numbers) \$

Purpose: Breast Cancer Research Semipostal Stamps

Is any Portion of this Sale a Charitable Tax Deduction?
 Yes No

If "Yes," the fair market value of the postage portion of the foregoing stamps equals the First-Class postage rate.

By (Signature and Title) [C] Date March 23, 2002

PS Form 1096, April 1999

*The fair market value of the postage portion of a semipostal stamp is the First-Class first-ounce rate at the time of purchase.



OFFICE OF
CHIEF COUNSEL

DEPARTMENT OF THE TREASURY
INTERNAL REVENUE SERVICE
WASHINGTON, D.C. 20224

DEC 21 2001

David Failor
Acting Manager, Stamp Services
United States Postal Service
475 L'Enfant Plaza, SW, Room 5670
Washington, DC 20260-2435

Dear Mr. Failor:

Commissioner Rossotti has asked me to respond to your inquiry regarding the deductibility of amounts paid for postage stamps issued pursuant to the 9/11 Heroes Stamp Act of 2001, Pub. L. No. 107-67, § 652, 111 Stat. 514 (2001).

In order to afford the public a direct and tangible way to provide assistance to the families of emergency relief personnel killed or permanently disabled in the line of duty in connection with the terrorist attacks against the United States on September 11, 2001, the 9/11 Heroes Stamp Act directs the United States Postal Service to issue special first-class postage stamps (Heroes stamps), to be sold for an amount at least 15 percent greater than the regular rate of first-class postage. The excess is to be transferred to the Federal Emergency Management Agency (FEMA).

When a taxpayer, with the intention of making a gift, purchases an item of value from a qualified charity, the excess of the payment over the value received is a charitable contribution. Accordingly, taxpayers who purchase a Heroes stamp from the United States Postal Service are entitled to treat as a charitable contribution the difference between the price of the Heroes stamp, and the price of regular first-class postage.

If you have any further questions, please contact Sean Dwyer at (202) 622-5020.

Sincerely,

A handwritten signature in cursive script that reads "Kimberly L. Koch".

KIMBERLY L. KOCH
Acting Chief, Branch 1
Associate Chief Counsel
(Income Tax & Accounting)



POSTAL NEWS

FOR IMMEDIATE RELEASE
[INSERT DATE]

Contact: [INSERT YOUR NAME]
[INSERT YOUR PHONE NUMBER]
Internet: www.usps.com

MEDIA ADVISORY/PHOTO OPPORTUNITY

[CITY NAME] Post Office Invites Community to Honor the Heroes of 2001

- WHAT:** To provide assistance to the families of the emergency relief personnel killed or permanently disabled in the line of duty in connection with the September 11, 2001, terrorist attacks, the U.S. Postal Service is challenging its employees and local citizens to use the *Heroes of 2001* postage stamp on their cards and letters. **[BRIEFLY DESCRIBE EVENT ACTIVITIES]**
- WHO:** **[LIST NOTABLE EVENT PARTICIPANTS, PERFORMERS, ETC.]**
- WHEN:** **[LIST DATE AND TIME]**
- WHERE:** **[LIST EXACT STREET LOCATION]**
- DETAILS:** The *Heroes of 2001* is the second semipostal stamp issued by the U.S. Postal Service. This new stamp will be issued nationwide on June 7, 2002, and will be on sale no later than December 31, 2004. Funds raised from the sale of the *Heroes of 2001* semipostal stamp (net of the Postal Service's reasonable costs) will be transferred to the Federal Emergency Management Agency to provide assistance to the families of the emergency relief personnel killed or permanently disabled in the line of duty in connection with the September 11, 2001, terrorist attacks.
- CONTACTS:** **[LIST NAMES AND TELEPHONE NUMBERS OF POSTMASTER AND/OR AREA PUBLIC AFFAIRS AND COMMUNICATIONS MANAGER]**

###



POSTAL NEWS

FOR IMMEDIATE RELEASE
[INSERT DATE]

Contact: [INSERT YOUR NAME]
[INSERT YOUR PHONE NUMBER]
Internet: www.usps.com

[CITY NAME] Post Office Invites Community to Honor Local Heroes; Postal Service Issues Heroes of 2001 Fundraising Stamp

[CITY AND STATE] — As a result of recently enacted legislation, the [NAME] Post Office has joined a nationwide campaign to provide assistance to the families of the emergency services personnel killed or permanently disabled in the line of duty in the September 11, 2001, terrorist attacks. Employees of the Post Office are encouraging the use of the *Heroes of 2001* semipostal stamp.

The *Heroes of 2001* semipostal stamp is the second in U.S. history to have its net proceeds above postage (and the Postal Service's reasonable costs) earmarked for specified purposes.

"The self-adhesive *Heroes of 2001* semipostal stamp is now available," said Postmaster [FIRST AND LAST NAME]. "The Postal Service has a proud tradition of issuing stamps to help raise awareness of social issues. This stamp continues our active role in helping members of affected communities. We encourage everyone to purchase and use the stamp on your cards and letters."

[INSERT ONE PARAGRAPH DESCRIBING THE STAMP EVENT THAT TOOK PLACE OR WILL TAKE PLACE AT YOUR LOCAL POST OFFICE OR OTHER LOCATION]

The 45-cent, self-adhesive *Heroes of 2001* semipostal stamp is valid for postage at the current First-Class Mail, first-ounce letter rate in effect at the time of purchase (currently 34 cents), with the differential (less the Postal Service's reasonable costs) going to the Federal Emergency Management Agency to provide assistance to the families of emergency relief personnel killed or permanently disabled in the line of duty in connection with the September 11th terrorist attacks. The 11-cent differential consists of a tax-deductible contribution.

The *Breast Cancer Research* semipostal stamp is the first stamp in U.S. history to have its net proceeds earmarked for a specific cause. To date more than \$25 million has been raised for breast cancer research.

Both the *Heroes of 2001* stamp and *Breast Cancer Research* stamp are available for purchase at Post Offices across the country, by toll-free telephone orders at 800-STAMP-24, and by online orders at the Postal Store at www.usps.com.

###

Area Public Affairs and Communications Managers

RALPH STEWART
MANAGER PUBLIC AFFAIRS AND COMMUNICATIONS
EASTERN AREA US POSTAL SERVICE
615 CHESTNUT ST 15TH FLOOR
PO BOX 40593
PHILADELPHIA PA 19197-0593
215-931-5054

JIM MRUK
MANAGER PUBLIC AFFAIRS AND COMMUNICATIONS
GREAT LAKES AREA US POSTAL SERVICE
244 KNOLLWOOD DR 4TH FLOOR
BLOOMINGDALE IL 60117-2208
630-539-6565

DIANE TODD
MANAGER PUBLIC AFFAIRS AND COMMUNICATIONS
NY METRO AREA US POSTAL SERVICE
421 EIGHTH AVE RM 5114
NEW YORK, NY 10199-9681
212-330-3167

DAVID MAZER
MANAGER PUBLIC AFFAIRS AND COMMUNICATIONS
PACIFIC AREA US POSTAL SERVICE
7001 S CENTRAL AVE ROOM 364A
LOS ANGELES CA 90052-9641
323-586-1212

DEBRA HAWKINS
MANAGER, PUBLIC AFFAIRS AND COMMUNICATIONS
NORTHEAST AREA US POSTAL SERVICE
6 GRIFFIN RD N
WINDSOR, CT 06006-9876
860-285-7265

HELEN SKILLMAN AND DEBORAH YACKLEY
PUBLIC AFFAIRS AND COMMUNICATIONS
CAPITOL METRO US POSTAL SERVICE
10320 LITTLE PATUXENT PKWY STE 308
COLUMBIA MD 21044-5210
202-268-3053

SCOTT BUDNY
MANAGER PUBLIC AFFAIRS AND COMMUNICATIONS
WESTERN AREA US POSTAL SERVICE
1745 STOUT ST STE 1075
DENVER CO 80299-7500
303-313-5125

DAN DE MIGLIO
MANAGER PUBLIC AFFAIRS AND COMMUNICATIONS
PACIFIC AREA US POSTAL SERVICE
390 MAIN STREET STE 200
SAN FRANCISCO CA 94105-8000
415-536-6490

CESTA AYERS JR.
(A) MANAGER PUBLIC AFFAIRS AND COMMUNICATIONS
SOUTHWEST AREA US POSTAL SERVICE
7800 N STEMMONS FREEWAY
DALLAS TX 75247-4220
214-819-8748

EARL C ARTIS JR
MANAGER PUBLIC AFFAIRS AND COMMUNICATIONS
SOUTHEAST AREA US POSTAL SERVICE
225 NORTH HUMPHREY BLVD
MEMPHIS TN 38166-0832
901-747-7544

Government Relations Managers and Representatives

State	Contact	Telephone Number
Alabama	Laurie Solnik	202-268-3743
Alaska	Jennifer Alvarez	202-268-7839
American Samoa	Jennifer Alvarez	202-268-7839
Arizona	Renee Gadson	202-268-7217
Arkansas	Faith Beamon	202-268-3745
California	Bill Weagley	202-268-3745
Connecticut	Jo Waterman	202-268-6748
Colorado	Renee Gadson	202-268-7217
Delaware	Jo Waterman	202-268-6748
District of Columbia	Rebecca Sumner	202-268-3755
Florida	Laurie Solnik	202-268-3743
Georgia	Jim Quirk	202-268-8468
Guam	Jennifer Alvarez	202-268-7839
Hawaii	Jennifer Alvarez	202-268-7839
Idaho	Jennifer Alvarez	202-268-7839
Illinois	Cynthia Puryear	202-268-3750
Indiana	Rebecca Sumner	202-268-3755
Iowa	Sheila Meyers	202-268-7505
Kansas	Renee Gadson	202-268-7217
Kentucky	Pat Irons	202-268-3744
Louisiana	Faith Beamon	202-268-3754
Maine	Kathy Sitterle	202-268-6027
Maryland	Rebecca Sumner	202-268-3755
Massachusetts	Jo Waterman	202-268-6748
Michigan	Cynthia Puryear	202-268-3750
Minnesota	Sheila Meyers	202-268-7505
Mississippi	Laurie Solnik	202-268-3743
Missouri	Sheila Meyers	202-268-7505
Montana	Jennifer Alvarez	202-268-7839
Nebraska	Sheila Meyers	202-268-7505
Nevada	Jennifer Alvarez	202-268-7839
New Hampshire	Jo Waterman	202-268-6748
New Jersey	Jo Waterman	202-268-6748
New Mexico	Renee Gadson	202-268-7217
New York	Kathy Sitterle	202-268-6027
North Carolina	Jim Quirk	202-268-8468
North Dakota	Sheila Meyers	202-268-7505
Ohio	Pat Irons	202-268-3744
Oklahoma	Faith Beamon	202-268-3754
Oregon	Jennifer Alvarez	202-268-7839
Pennsylvania	Rebecca Sumner	202-268-3755
Puerto Rico	Kathy Sitterle	202-268-6027
Rhode Island	Jo Waterman	202-268-6748
South Carolina	Jim Quirk	202-268-8468



State	Contact	Telephone Number
South Dakota	Sheila Meyers	202-268-7505
Tennessee	Jim Quirk	202-268-8468
Texas	Faith Beamon	202-268-3754
Utah	Renee Gadson	202-268-7217
Vermont	Kathy Sitterle	202-268-6027
Virgin Islands	Kathy Sitterle	202-268-6027
Virginia	Pat Irons	202-268-3744
Washington	Jennifer Alvarez	202-268-7839
West Virginia	Pat Irons	202-268-3744
Wisconsin	Cynthia Puryear	202-268-3750
Wyoming	Renee Gadson	202-268-7217

— *Community Relations,
Public Affairs and Communications, 5-16-02*

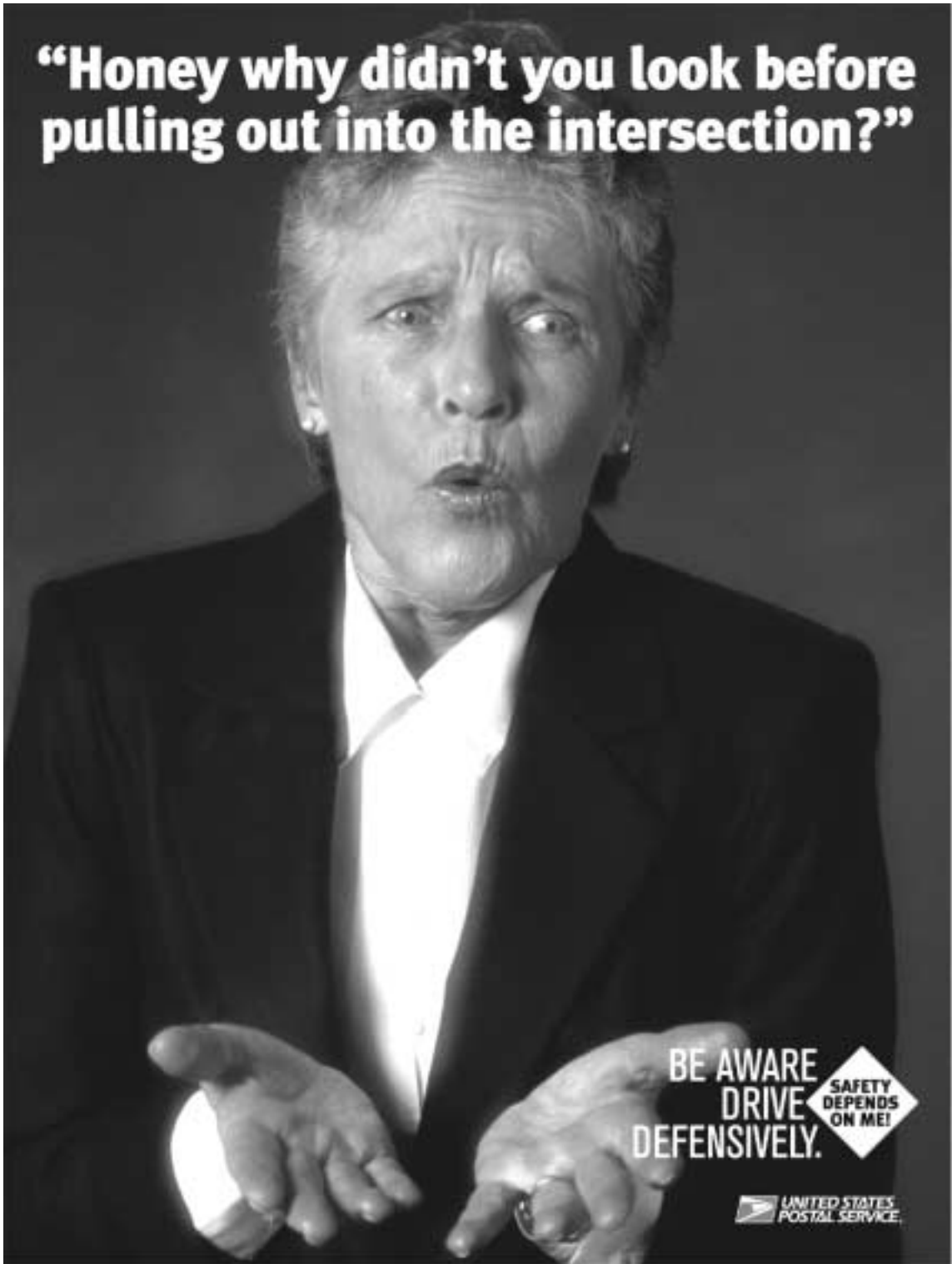

“Honey why didn’t you look before pulling out into the intersection?”

**BE AWARE
DRIVE
DEFENSIVELY.**

**SAFETY
DEPENDS
ON ME!**

 **UNITED STATES
POSTAL SERVICE**



Pictorial Cancellation Announcement

<p>Complete this announcement and forward it to the following address:</p> <p>PICTORIAL CANCELLATIONS PROGRAM MANAGER STAMP SERVICES US POSTAL SERVICE 475 L'ENFANT PLZ SW RM 4474-EB WASHINGTON DC 20260-2437</p>	<p><i>Insert pictorial cancellation Copy here (Camera ready or reproducible) No larger than 4" horizontal x 2" vertical (the dimensions of this box)</i></p>
---	--

Postal Service Contact (name, address, phone)	
Station Date(s)	
Sponsor	
Station Name	
<i>Complete</i> Street Address or PO Box Number	
City/State/ZIP+4	

Mail Cancellation Requests to:

Station Name	
Addressee Name (usually "Postmaster")	
<i>Complete</i> Street Address or PO Box 9998	
City/State/ZIP+4	

CUT ALONG DOTTED LINE





Administrative Services

ASM REVISION

Photo Identification Requirements

Effective May 16, 2002, *Administrative Support Manual* (ASM) 13, sections 277.1 and 277.233 are revised. We revised the sections to require that every postal employee; postal contractor; and temporary employee, including casual employees, have a PS Form 4098-F, *Employee Identification (face)*, or an equivalent photo identification card. Districts must comply with this requirement by the beginning of fiscal year 2003. Also, Postal Service managers must ensure that no part of the employee's social security number is displayed on the employee's photo identification card. This requirement applies to all employee photo identification cards issued after May 31, 2002.

We will incorporate this revision into the printed version of ASM 14 and into an incremental update of the online ASM 13, which is accessible through the Postal Service PolicyNet page on the intranet at <http://blue.usps.gov/cpim>; click on *Manuals*.

Administrative Support Manual (ASM)

	*	*	*	*	*
2	Audits and Investigations				
	*	*	*	*	*
27	Security				
	*	*	*	*	*
277	Identification Security				
	*	*	*	*	*

277.1 Purpose

[Revise section 277.1 to read as follows:]

Identification is issued for security control of access to postal premises and operations and to identify individuals as Postal Service employees. Every postal employee; postal contractor; and temporary employee, including casual employees, must have photo identification. Postal Service managers must ensure that no employee photo identification (i.e., photo identification) card displays any part of the employee's social security number. The Postal Inspection Service provides guidelines for all Postal Service identification programs.

277.2 Types of Accredited Identification

* * * * *

277.23 Field Only

* * * * *

[Revise the heading and text of section 277.233 to read as follows:]

277.233 Form 4098-F and Employee Identification

The responsible district manager issues Form 4098-F, *Employee Identification (face)*, or an equivalent photo identification card, to every postal employee; postal contractor; and temporary employee, including casual employees. All employees must wear and visibly display Form 4098-F or an equivalent photo identification card while officially employed and on duty (see section 277.3). All cards must include, at a minimum, the name of the employee, the facility to which they are assigned, and a photo of the employee. Each district manager is responsible for Form 4098-F or equivalent photo identification cards. Form 4098-F and equivalent photo identification cards provide visible identification of employees while on the workroom floor and serving customers outside of postal facilities. While on duty away from the facilities servicing customers, each employee must wear and display Form 4098-F or an equivalent photo identification card.

* * * * *

— Security Group,
Postal Inspection Service, 5-16-02

HANDBOOK REVISION/ORDERING INSTRUCTIONS

Handbook AS-805, Information Security

Handbook AS-805 has been revised and retitled and is now available from the Material Distribution Center (MDC) and the Postal Service PolicyNet page at <http://blue.usps.gov/cpim>; click on *HBKs*.

The April 1994 edition of Handbook AS-805 was titled *Information Systems Security*. The March 2002 edition of Handbook AS-805 obsoletes Handbook AS-818, *Local Area Network and Personal Computer Security*; MI AS-830-92-11, *Electronic Messaging System Policy*; MI AS-840-95-12, *Employee Access to the Internet*; MI AS-850-97-3, *Security Certification and Accreditation of Sensitive Applications and Systems*; and MI AS-870-90-7, *Computer Virus Guidelines*. Please recycle all copies of these documents, as well as the April 1994 edition of Handbook AS-805.

The Postal Service relies extensively on computerized systems and electronic data to support its mission. The security of these systems and data is essential to avoid disruptions in critical operations, data tampering, fraud, and inappropriate disclosure of sensitive information. The revised Handbook AS-805 addresses the technologies that support the Postal Service and reflects industry and government prudent practices.

The policies in Handbook AS-805 apply to all Postal Service personnel, which includes employees, contractors, vendors, business partners, and any other authorized users of Postal Service information resources. The policies cover all information systems, applications, products, services networks, computer-controlled mail processing and mail handling equipment, and resources sponsored by, operated on behalf of, or developed for the Postal Service.

Employees may order copies of Handbook AS-805 in the following ways:

- **Touch tone order entry:** Call 800-332-0317, select option 1, then option 2.
- **E-mail:** Complete PS Form 7380, *MDC Supply Requisition* (either manually or by F3Fill) and send it as an attachment to the e-mail address *MDC Customer Service*.
- **Mail:** Mail a completed PS Form 7380 to the MDC at the following address:

SUPPLY REQUISITIONS
MATERIAL DISTRIBUTION CENTER
500 SW GARY ORMSBY DR
TOPEKA KS 66624-9702

The relevant ordering information for Handbook AS-805 is as follows:

PSN:	7610-03-000-9136
PSIN:	HBKAS805
Unit of Issue:	EA
Price:	\$4.67
Edition Date:	March 2002
Quick Pick Number:	N/A

— *Corporate Information Security Office,
Information Technology, 5-16-02*

Child Alert Program

May 2002

Have You Seen Any of These Missing Children?

Please participate in the NALC/USPS Child Alert Program. Tear out this page and carry it with you. If you have information on any of these missing persons, tell your postal supervisor.



Joshua Aberant
 Born: 5-18-85
 Date Missing: 3-18-02
 Missing From: Budd Lake, NJ



Benjamin Adams
 Born: 8-23-86
 Date Missing: 2-5-02
 Missing From: Greenville, SC



Amy Conteh
 Born: 12-15-85
 Date Missing: 12-15-01
 Missing From: Silver Spring, MD



Aleah Coultas
 Born: 10-16-98
 Date Missing: 2-1-02
 Missing From: Springfield, IL



Katie Hinton
 Born: 11-15-85
 Date Missing: 3-3-02
 Missing From: Atlanta, GA



Scott Maynard
 Born: 12-14-93
 Date Missing: 11-26-01
 Missing From: Greensboro, NC

**Please call the National Center for Missing and Exploited Children
 Hot Line 1-800-843-5678
 TDD 1-800-826-7653**

CUT ALONG DOTTED LINE



Missing Children Poster Display Instructions

Please display this poster prominently on bulletin boards in retail lobbies of main Post Offices, classified stations, and branches. Operators of contract postal units may display this poster at their option.

Companion posters, authorized for display on bulletin boards maintained by employee organizations, appear periodically in *The Postal Record*, a publication for members of the National Association of Letter Carriers.

This poster is published in cooperation with the National Center for Missing and Exploited Children, the United States Department of Justice, and the National Association of Letter Carriers. Information appearing on this poster is selected solely by NCMEC.

In addition to *Postal Bulletin* updates, NCMEC distributes information via broadcast fax. Notification of newly reported missing children is sent to designated district "Missing Children" coordinators at fax numbers provided by district managers. Within 24 hours of receipt of a facsimile Missing Children poster, district coordinators should distribute copies to all postal facilities in their districts. Missing Children posters are to be displayed for 30 days in Post Office lobbies, workroom floor areas, and other postal facilities, unless notification is received (from NCMEC) to remove a particular poster sooner. The broadcast fax network is used to distribute posters and information in only the most urgent cases of missing and exploited children. This system supplements, but does not replace, the missing children information in this *Postal Bulletin*.

Missing Children posters are available to the U.S. Postal Service only as described above. If postal employees are contacted by individuals or local agencies about displaying a sign or poster of a missing child in local Post Offices, the individual or agency should be politely informed that the U.S. Postal Service displays only those posters provided by NCMEC, because it has been designated by the U.S. Department of Justice to be the national clearinghouse and resource center for missing and exploited children. The individual or agency should then be referred to NCMEC at 1-800-843-5678.

May 2002

Have You Seen Any of These Missing Children?

Please participate in the NALC/USPS Child Alert Program. Tear out this page and carry it with you. If you have information on any of these missing persons, tell your postal supervisor.



Brittany McAllister
Born: 3-8-87
Date Missing: 3-1-02
Missing From: Las Vegas, NV



Alexandra Ortiz
Born: 1-18-94
Date Missing: 12-7-01
Missing From: Miami, FL



Barbara Stevens
Born: 11-13-86
Date Missing: 3-26-02
Missing From: Hartford, CT

**Please call the National Center for Missing and Exploited Children
Hot Line 1-800-843-5678
TDD 1-800-826-7653**

CUT ALONG DOTTED LINE



Missing Children Poster Display Instructions

Please display this poster prominently on bulletin boards in retail lobbies of main Post Offices, classified stations, and branches. Operators of contract postal units may display this poster at their option.

Companion posters, authorized for display on bulletin boards maintained by employee organizations, appear periodically in *The Postal Record*, a publication for members of the National Association of Letter Carriers.

This poster is published in cooperation with the National Center for Missing and Exploited Children, the United States Department of Justice, and the National Association of Letter Carriers. Information appearing on this poster is selected solely by NCMEC.

In addition to *Postal Bulletin* updates, NCMEC distributes information via broadcast fax. Notification of newly reported missing children is sent to designated district "Missing Children" coordinators at fax numbers provided by district managers. Within 24 hours of receipt of a facsimile Missing Children poster, district coordinators should distribute copies to all postal facilities in their districts. Missing Children posters are to be displayed for 30 days in Post Office lobbies, workroom floor areas, and other postal facilities, unless notification is received (from NCMEC) to remove a particular poster sooner. The broadcast fax network is used to distribute posters and information in only the most urgent cases of missing and exploited children. This system supplements, but does not replace, the missing children information in this *Postal Bulletin*.

Missing Children posters are available to the U.S. Postal Service only as described above. If postal employees are contacted by individuals or local agencies about displaying a sign or poster of a missing child in local Post Offices, the individual or agency should be politely informed that the U.S. Postal Service displays only those posters provided by NCMEC, because it has been designated by the U.S. Department of Justice to be the national clearinghouse and resource center for missing and exploited children. The individual or agency should then be referred to NCMEC at 1-800-843-5678.

Customer Relations

Mail Alert

The mailings below will be deposited in the near future. Offices should honor the requested home delivery dates. Mailers wishing to participate in these alerts, for mailings of 1 million pieces or more, should contact Business Service Network Integration at 703-292-3867 at least 1 month preceding the requested delivery dates. The Postal Service

also offers electronic Mail Alerts via ADVANCE. For more information, see the *ADVANCE Notification & Tracking System Technical Guide* on the Internet at <http://www.ribbs.usps.gov/files/advance/ADVTECH.PDF> or contact the National Customer Support Center at 800-458-3181.

Title of Mailing	Class and Type of Mail	Requested Delivery Dates	Number of Pieces (Millions)	Distribution	Presort Level	Comments
JC Penney Memorial Day (Credit Card Customer)	Standard/Flat	5/18–5/21	18.0	National	Car-Rt	Harte-Hanks
Decision Magazine	Standard/Flat	5/27–6/1	1.1	National	Car-Rt, Barcode, 3/5 Digit, Basic	Minneapolis, MN
JCP Saturday Sale Preview	Standard/Flat	5/28–5/30	17.4	National	Car-Rt	Harte-Hanks
Sportsman's Guide	Standard/Catalog	5/28–5/31	1.4	National	3/5 Digit, Car-Rt	Quad Graphics, Martinsburg
JCP Summer Blow-out Catalog	Standard/Postcard	5/29–5/31	10.5	National	Car-Rt	Harte-Hanks
Sally Beauty Supply	Standard/Letter	5/29–5/31	1.1	National	3/5 Digit, Car-Rt, 5% residual	Time sensitive

— Business Service Network Integration, Service and Market Development, 5-16-02

ALL OFFICES WITH CITY MOTORIZED, RURAL, AND HIGHWAY CONTRACT BOX DELIVERY ROUTES

Mailbox Improvement Week, May 20–25

Each year, the Postal Service designates the third full week of May to encourage customers on city motorized, rural, or highway contract box delivery routes to examine and, where necessary, improve the appearance of their mailboxes. Neat, attractive mailboxes make a significant contribution to the appearance of the countryside and to streets in suburban areas. Mailbox Improvement Week, May 20–25, calls attention to the need for providing mailboxes that are:

1. Approved by the Postmaster General.
2. Designed to protect the mail from weather.
3. Safe to use.
4. Conveniently located.
5. Neat in appearance.

Mailboxes that meet these five important requirements help delivery and collection operations and improve service to the entire route. There are two approved styles of curbside mailboxes: (1) traditional design, in three standard

sizes (see Exhibit A on page 26); and (2) contemporary design, also in three sizes (see Exhibit B on page 26). USPS Std 7 governs the design and specifications of curbside mailboxes and includes provisions for improved quality of the product and a new category, locked mailboxes.

Notice 209

Postmasters should send Notice 209, *Mailbox Improvement Week*, to all rural and highway contract box delivery route customers the week before Mailbox Improvement Week to alert them of the event. Notice 209 can be requisitioned from the Material Distribution Center (MDC) as follows:

- **Touch Tone Order Entry:** Call 800-332-0317, choose option 1, then option 2.
- **E-mail:** Complete PS Form 7380, *MDC Supply Requisition* (manually or by F3 Fill), and send it as an attachment to the e-mail address *MDC Customer Service*.

- **Mail:** Mail a completed PS Form 7380 to the following address:

SUPPLY REQUISITIONS
500 SW GARY ORMSBY DR
TOPEKA KS 66624-9702

The relevant ordering information for Notice 209 is as follows:

PSN: 7610-03-000-9145
PSIN: NOT209
Unit of Issue: EA
Quick Pick #: 496
Bulk Pack Quantity: N/A
Price: \$.0242
Edition Date: November 2000

City Motorized, Rural, and Highway Contract Box Delivery Routes

Customers must use *only* approved traditional or contemporary curbside mailboxes for new installations or replacements. However, a customer may use a custom-built curbside mailbox if the local postmaster gives prior approval and the mailbox conforms generally to the same requirements as approved manufactured curbside mailboxes relative to the flag, size, strength, and quality of construction. Carriers on motorized city routes may continue to serve mailboxes that are designed primarily for use by customers receiving door delivery and that have been erected and served under previous regulations (see Exhibit C on this page). However, carriers should advise customers that they may use only approved curbside mailboxes when replacing these types of mailboxes. A list of approved manufacturers of traditional curbside mailboxes appears on pages 27–28.

For motorized city routes, and where the use of street names and house numbers is authorized on rural and highway contract box delivery routes, the mailbox must display the number on the side of single mailboxes or on the door of grouped mailboxes. If the mailbox is on a street other than the one on which the customer resides, the street name and house number must be on the mailbox. When rural and highway contract box delivery route customers have assigned box numbers, the numbers must appear on the side of single mailboxes or on the doors of grouped mailboxes, visible to the approaching carrier. The street number, box number, and/or any other address information must be inscribed in contrasting color in neat letters and numerals not less than 1 inch in height. In all instances, placing the owner's name on the box is optional.

Exhibit A

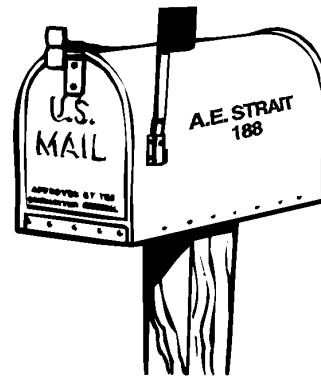

Exhibit B

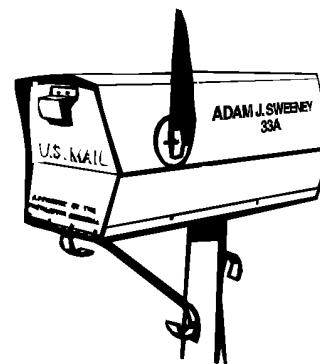
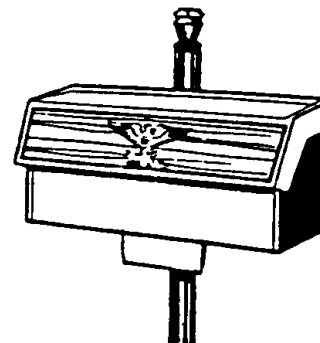

Exhibit C



Motorized city, rural, and highway contract box delivery route customers should be encouraged but not required to group mailboxes whenever practical, especially where many mailboxes are located at or near crossroads, service turnouts, or similar locations. Customers should also paint mailboxes and supports/posts and keep them rust-free. Advertising on mailboxes and supports/posts is prohibited.

In areas where snow removal is a problem, the Postal Service suggests using a semi-arch or extended arm-type support (see Exhibit D), which allows snowplows to sweep near or under mailboxes without damaging supports and provides easy access to the mailboxes by carriers and customers.

Exhibit D

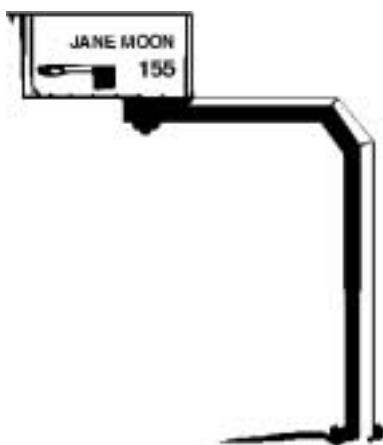

Generally, mailboxes are installed at a height of 41–45 inches from the road surface to the bottom of the mailbox or point of mail entry. Mailboxes are set back 6–8 inches from the front face of the curb or road edge to the mailbox door. However, because of varying road and curb conditions and other factors, the Postal Service recommends that customers contact the postmaster or carrier before erecting or replacing mailboxes and supports.

Location

Customers must place mailboxes on motorized city, rural, and highway contract box delivery routes so a carrier can safely and conveniently serve them without leaving his or her vehicle. The mailboxes must be on the right-hand side of the road in the carrier’s travel direction in all cases where traffic conditions make it dangerous for the carrier to drive to the left to reach the mailboxes, or where doing so would constitute a violation of traffic laws and regulations (*Postal Operations Manual*, POM, 632.6, Apartment House Receptacles, exempts apartment houses and other multiple dwellings from this rule). On new rural and highway contract box delivery routes, all mailboxes must be on the right-hand side of the road in the direction of the route line

of travel. Mailbox placement must conform with state laws and highway regulations. City motorized, rural, and highway contract box delivery route carriers are subject to the same traffic laws and regulations as other motorists. Customers must remove obstructions, including vehicles, trash cans, and snow, that impede efficient delivery. Except when a mailbox is temporarily blocked, carriers must have access to the mailbox without leaving the vehicle unless authorized to dismount.

Mailbox Supports

The Postal Service does not regulate mailbox supports in any way except for purposes of carrier safety and delivery efficiency. Posts and other supports for curbside mailboxes are owned and controlled by customers, who are responsible for ensuring that posts are neat and adequate in strength and size. Heavy metal posts, concrete posts, and miscellaneous items of farm equipment, such as milk cans filled with concrete, are examples of potentially dangerous supports. The ideal support is an assembly that bends or falls away when struck by a vehicle. Post or support designs may not represent effigies or caricatures that disparage or ridicule any person. Customers may attach the box to a fixed or movable arm. POM 632.5, Curbside Mailboxes, specifies postal regulations regarding construction and placement of mailboxes and supports on motorized city, rural, and highway contract box delivery routes.

The Federal Highway Administration (FHWA) has determined that mailbox supports no larger than 4 inches by 4 inches, or a 2-inch diameter standard steel or aluminum pipe, buried no more than 24 inches, should safely break away if struck by a vehicle. According to FHWA, the mailbox must also be securely attached to its post to prevent separation if struck. See Exhibits E (page 33) and F (page 34) for examples of mailbox mountings and supports suggested by the FHWA.

The following list of curbside mailboxes approved by the postmaster general supersedes all previously published lists of approved manufacturers.

Curbside Mailboxes Approved by the Postmaster General

USPS-STD-7B

Manufacturers and Models

AMERICAN POSTAL MANUFACTURING CO
500 W OKLAHOMA AVE
MILWAUKEE WI 53207-2649
1812 (contemporary)

ARCHITECTURAL MAILBOXES
2741 PLAZA DEL AMO STE 206
TORRANCE CA 90503
Oasis 5100 (Locking, full-service)

ARMADILLO ENCLOSURES INC
PO BOX 462199
ESCONDIDO CA 92046-2199
1000F (Locking, full-service)
1000R (Locking, full-service)

DAVIS TOOL INC
215 SW WOOD ST
HILLSBORO OR 97123
1022-X-LIM (Locking, limited service)
1123-X-LIM (Locking, limited service)

FLEXIBLE COMPOSITES CO
2629 MOUNT JORDAN RD
SANDY UT 84092
CMB-01 (Traditional)

FUORISERIE IMPORTS
61 PEARL ST STE 503
BROOKLYN NY 11201
ECCO 3 (Traditional)

FUJI INDUSTRIES CO
1200B MELISSA LN
BENTONVILLE AR 72712
HOU-MB-05 (Traditional)

IMPERIAL MAILBOX SYSTEMS
3901 NORRIS LN
MILLBROOK AL 36054 001-00
001-01 (Contemporary)
001-04 (Contemporary)
001-06 (Contemporary)
001-07 (Contemporary)
001-08 (Contemporary)
001-09 (Contemporary)
002-00 (Contemporary)

JAMESTOWN ADVANCED PRODUCTS INC
2855 GIRTS RD
JAMESTOWN NY 14701 23
49 (Traditional)
54 (Traditional)
56 (Traditional)

JANZER CORP
9 CHELTEN WAY
TRENTON NJ 08638-5000
StoneyBrae (Traditional)

LETTER LOCKER LLC
20594 OTTAWA RD
APPLE VALLEY CA 92308-6253
Supreme Letter Locker (Locking, full-service)
Standard Letter Locker (Locking, full-service)

MAIL SYSTEMS NW INC
12365 SW TOOZE RD
SHERWOOD OR 97140-7205
Belaire 16 (Locking, limited-service)
Belaire 20 (Locking, full-service)
Senator 16 (Locking, full-service)
Senator XL (Locking, full-service)

SECURITY MANUFACTURING
815 S MAIN ST
GRAPEVINE TX 76051
Trailmaster (Locking, full-service)

SOLAR GROUP INC
PO BOX 525
TAYLORSVILLE MS 39168-0525
AR15 (Contemporary)
CENTURY 2000 (Contemporary)
CL-1 (Contemporary)
ES15 Estate (Contemporary)
PL-10 (Traditional)

STEEL CITY CORP
190 N MERIDIAN RD
YOUNGSTOWN OH 44501-1227
LE Brute (Traditional)
IB IronBox (Traditional)
PX Polybox (Traditional)
2D Two Door Brute (Traditional)
T1 (Traditional)
T2 (Traditional)
T3 (Traditional)

STEP2 COMPANY
10010 AURORA HUDSON RD
STREETSBORO OH 44241-0412
5402 (Contemporary)
5452 (Contemporary)

UNEK PRODUCTS INC
4620 ROYAL LANE
DALLAS TX 75229
PV-300 (Locking, full-service)
PV-400 (Locking, full-service)

VEEDERS MAILBOX INC
10050 MONTGOMERY RD #324
CINCINNATI OH 45242
LGVMB-G (Traditional)
LGVMB-SS (Traditional)
SMVMB-B (Traditional)
SMVMB-SS (Traditional)

Cluster Box Units and All-Weather Parcel Lockers

During Mailbox Improvement Week, postmasters and managers or their designees must review all cluster box units (CBUs), neighborhood delivery and collection box units (NDCBUs), and outdoor parcel lockers (OPLs) in their delivery areas to identify any hazards or irregularities, and they must record the results of the review. PS Form 8143, *Equipment Checklist and Follow-up Review*, is the suggested format to use in conducting and recording the reviews. PS Form 8143 is available only in this *Postal Bulletin* (see Exhibit G on page 35) and must be reproduced locally. Employees conducting the reviews must complete PS Form 1624, *Delivery/Collection Equipment Work Request*, for any equipment that poses a safety hazard to postal customers or employees. Requisition PS Form 1624 from the MDC using normal ordering procedures

(described on pages 25–26). The relevant ordering information for PS Form 1624 is as follows:

PSN: 7530-01-000-9392
 PSIN: PS1624
 Unit of Issue: SE
 Quick Pick #: N/A
 Bulk Pack Quantity: N/A
 Price: \$.0411
 Edition Date: July 1992

Equipment Review Procedure

Employees must use the CBU and parcel locker equipment checklist and follow-up review procedure when examining the condition of CBUs, NDCBUs, and OPLs. You must:

1. List the 5-digit, USPS-marked Postal ID number of the unit. This is usually visible on the front or side of the body or pedestal. If a Postal ID number is not available, list the unit location, equipment type, and manufacturer in the left-hand column. If you are able to access the back of the unit, list the unit's vendor-supplied serial number.
2. Assign each checklist item one of the following ratings:
 - a. OK — Equipment does not need attention for this item.
 - b. X — Equipment needs attention for this item.
 - c. NA — Item does not apply to this particular piece of equipment.
3. When examining the equipment, use the instructions below to complete PS Form 8143:
 - a. Check equipment. All CBUs, NDCBUs, and OPLs should be straight, vertical, and firmly mounted with the customer compartments facing away from the street. Visually verify that four bolts/nuts are firmly in place securing the pedestal to the concrete pad and also to the CBU, NDCBU, or OPL. Apply hand pressure to the top edge of the unit from the front side. While the unit may flex under the load, verify that the pedestal stays firmly mounted to the concrete and that the unit does not separate from the pedestal.
 - b. Check visible welds. Make note of cracked, broken, or rusted welds. For NDCBUs and OPLs only, tap the pedestal with a lightweight hammer, especially along the seams, to check for corrosion from the inside out or perforated corrosion.
 - c. For CBUs and NDCBUs, observe whether the carrier access door is locked and secure. Open it and observe whether it is bowed or warped and whether the door and locking bar operate smoothly. With

the carrier access door open, check whether restraining devices prevent the door from blowing closed. These devices, which may have to be set manually, should be serviceable.

- d. Ensure that the arrow lock operates smoothly and that the mounting hardware is tight. For NDCBUs and OPLs, the cover that protects the arrow lock from customer tampering must be serviceable and firmly attached.
 - e. For OPLs, the cover that protects the arrow lock from theft must be secured with the proper quantity of tamper resistant screw.
 - f. Ensure that all customer access doors are present, closed, and locked with no visible damage or signs of forced entry. Check that customer door numbers are readable.
 - g. Ensure that the exterior surface of the unit is free from rust and graffiti.
 - h. Examine the unit. Check it for defects or damage and whether it reflects a proper Postal Service image.
 - i. Check whether the unit and/or any protecting structure appears watertight and in good repair. Check whether there are any noticeable watermarks inside the unit or any wet mail.
 - j. Note any other conditions that require attention. Also, look for signs of vandalism such as pry marks on doors and locks.
4. Record the results of the inspection on the checklist.
 5. Submit the completed PS Form 1624 for each unit reviewed to the maintenance office responsible for centralized delivery equipment installation and/or repair in the area.

Carriers must note equipment deficiencies and report them to the postmaster, supervisor, or designee. The postmaster or designee must then submit PS Form 1624 reporting the equipment defects. In addition, carriers should complete PS Form 1767, *Report of Hazard, Unsafe Condition, or Practice*, for items that pose an immediate threat to safety, such as an improperly secured or leaning CBU. Order PS Form 1767 from the MDC using normal ordering procedures (described on pages 25–26). The relevant ordering information for PS Form 1767 is as follows:

PSN: 7530-01-000-9422
 PSIN: PS1767
 Unit of Issue: SE
 Quick Pick #: 141
 Bulk Pack Quantity: N/A
 Price: \$.0625
 Edition Date: December 1982

The postmaster or supervisor must immediately notify by telephone the office responsible for repair of reported hazards. The postmaster or supervisor must follow up to ensure that the work is satisfactorily completed and documented. The office responsible for repair should use its local buying authority to accomplish the repairs.

In April 2001 national contract for CBUs were awarded to American Locker Security Systems, Auth-Florence Manufacturing, and Security Manufacturing. OPLs are available only through the national contract with American Locker. All orders for CBUs and OPLs must be placed against these national contracts and all orders must be placed through e-Buy.

Cluster Box Units (CBUs)

USPS-B-1118F, June 1994

AMERICAN LOCKER SECURITY SYSTEMS INC
608 ALLEN ST
JAMESTOWN NY 14701-3966
800-828-9118
716-664-9600
716-483-2822 (fax)
Contract #072368-01-P-0378 — Place orders through e-Buy.
Unit is painted plastic — pedestal is painted plastic.

AUTH FLORENCE MANUFACTURING CO
591 MITCHELL RD
GLENDALE HEIGHTS IL 60139-2582
800-275-1747
630-545-1784
630-545-1896 (fax)
Contract #072368-01-P-0379 — Place orders through e-Buy.
Unit is anodized, painted aluminum — pedestal is anodized, painted stainless steel.

SECURITY MANUFACTURING CORP
815 SOUTH MAIN ST
GRAPEVINE TX 76051-5535
800-762-6937
817-329-1600
817-481-3993 (fax)
Contract #072368-01-P-0380 — Place orders through e-Buy.
Unit is anodized, painted aluminum — pedestal is anodized, painted aluminum.

Outdoor Parcel Locker (OPL)

USPS-B-1116A, September 13, 1989

AMERICAN LOCKER SECURITY SYSTEMS INC
608 ALLEN ST
JAMESTOWN NY 14701-3966
800-828-9118
716-664-9600
716-483-2822 (fax)
Contract #072368-01-P-0378 — Place orders through e-Buy.
Unit is plastic — pedestal is anodized aluminum. (Note: Pedestal can only be used on American Locker units.)

Replacement Pedestals — NDCBU Universal

AUTH FLORENCE MANUFACTURING CO
591 MITCHELL RD
GLENDALE HEIGHTS IL 60139-2582
800-275-1747
630-545-1784
630-545-1896 (fax)
Contract #072368-01-P-0379 — Place orders through e-Buy.
Pedestal is anodized aluminum. Does not fit Superior units.

SECURITY MANUFACTURING CORP
815 SOUTH MAIN ST
GRAPEVINE TX 76051-5535
800-762-6937
817-329-1600
817-481-3993 (fax)
Contract #072368-01-P-0380 — Place orders through e-Buy.
Pedestal is painted aluminum. Does not fit Superior or ARA units.

PAGE SPECIALTY COMPANY
5877 S FULTON WAY
ENGLEWOOD CO 80111-3719
CONTACT: BOB PAGE
800-327-7439
303-770-2842
303-771-6837 (fax)
No national contract.
Pedestal is painted aluminum. (Note: Page is a small business.)

GREG'S BODY & FABRICATING
PO BOX 813
FRUITLAND PARK FL 34731-0813
352-787-6262
352-787-6262 (fax)
No national contract.
Pedestal is painted aluminum.

Replacement Pedestals — OPL

AMERICAN LOCKER SECURITY SYSTEMS INC
608 ALLEN ST
JAMESTOWN NY 14701-3966
800-828-9118
716-664-9600
716-483-2822 (fax)
Contract #072368-01-P-0378 — Place orders through e-Buy.
Pedestal is anodized aluminum. (Note: Can be used only on American Locker units.)

Replacement Pedestals — Carousel/Rotating

PAGE SPECIALTY COMPANY
5877 SOUTH FULTON WAY
ENGLEWOOD CO 80111-3719
800-327-7439
303-770-2842
303-771-6837 (fax)
No national contract.
Pedestal is painted steel.

Apartment House Mail Receptacles — Horizontal and Vertical

USPS Publication 17, April 1982

USPS-STD-4B(RDD), Effective May 1, 1975

AMERICAN DEVICE MANUFACTURING
591 MITCHELL RD
GLENDALE HEIGHTS IL 60139-2582
800-275-1747
630-545-1784
630-545-1896 (fax)

AMERICAN EAGLE MANUFACTURING CO
3017 WHEELLOCK ST
DALLAS TX 75220-2944
800-488-4810
214-358-5544
214-358-2261 (fax)
Horizontal only.

AUTH FLORENCE MANUFACTURING CO
591 MITCHELL RD
GLENDALE HEIGHTS IL 60139-2582
800-275-1747
630-545-1784
630-545-1896 (fax)

BOMMER INDUSTRIES INC
PO BOX 187
LANDRUM SC 29356-0187
800-334-1654
864-457-3301
864-457-5370 (fax)

JENSEN INDUSTRIES INC
1946 E 46TH ST
LOS ANGELES CA 90058-2096
323-235-6800
800-882-6489 (fax)

MAIL SECURITY
714 W FLORENCE AVE
LOS ANGELES CA 90044-6106
323-750-7844
323-750-3433 (fax)
Vertical only.

SALSBURY INDUSTRIES
1010 E 62ND ST
LOS ANGELES CA 90001-1598
800-323-3003
213-232-6181
800-725-9393 (fax)

SECURITY MANUFACTURING CORP
815 S MAIN ST
GRAPEVINE TX 76051-5535
800-762-6937
817-329-1600
817-481-3993 (fax)

Locks and Cams, CBU/NDCBU

USPS-L-1172B, March 2, 1992

PSIN 0910A and B (locks) & PSIN 0913A through K (cams)

ESP LOCK PRODUCTS INC
375 HARVARD ST
LEOMINSTER MA 01453-3499
Contact: Sari Phibault
978-537-6121
978-537-1699 (fax)
No national contract.

HUDSON LOCK INC
81 APSLEY ST
HUDSON MA 01749-1547
Contact: Joanna Smith
978-562-3481
978-562-9859 (fax)
No national contract.

HURD CORPORATION
503 BOHANNON AVE
PO BOX 145
GREENEVILLE TN 37744-1450
423-787-8800
423-787-8817 (fax)
No national contract.

NATIONAL CABINET LOCK
200 OLD MILL RD
PO BOX 200
MAULDIN SC 29662-0200
Contact: Teresa Gilstrap
803-297-6655
803-297-9987 (fax)
Contract #266351-P0411

WIND CORPORATION
14 FINANCE DR
DANBURY CT 06810-4132
Contact: Patrick Wind
203-778-1001
203-778-1006 (fax)
Contract #266351-99-B-0987

Locks, Interlocking System, Parcel Locker, CBU

PSIN 0306P

USPS-L-1294A, November 19, 1996

KABA ILCO CORPORATION
400 JEFFREYS RD
PO BOX 2627
ROCKY MOUNT NC 27802-2627
Contact: Mike Philips (x256)
800-334-1381
252-446-3321
252-446-4702 (fax)
No national contract.

AMERICAN LOCKER SECURITY SYSTEMS INC
608 ALLEN ST
JAMESTOWN NY 14701-3966
800-828-9118
716-664-9600
716-483-2822 (fax)
No national contract.

Note: Apartment-style boxes are approved for indoor installation or protected outdoor locations. However, the Postal Service is prohibited from purchasing this equipment for new installations. You may order replacement parts for postal-owned equipment that was installed in the past.

State and Local Regulations

Some states have enacted laws that are more stringent and specific about the type of mailbox that may be used, the post or support that must be used to mount the mailbox, and the location of the delivery equipment. Regulations and recommendations published in this notice might not reflect appropriate requirements for your area. When providing guidance to the general public concerning mailbox placement and replacement, advise them not only of postal regulations but also of any mailbox regulations that you know have been enacted by state or local authorities.

Publicity

Postmasters should give these guidelines and suggestions maximum local publicity. Consult your area Public Affairs and Communications representative for further guidance and assistance in publicizing Mailbox Improvement Week. The news release on page 37 is provided for postmasters to distribute to daily or weekly newspapers or broadcast stations in their delivery area to promote Mailbox Improvement Week. Postmasters should retype the release double-spaced on Postal Service letterhead. It may also be helpful to alert the media to locations of particularly interesting mailboxes in your delivery area.

Responsibility

Motorized city, rural, and highway contract box delivery route carriers must cooperate to ensure the success of this endeavor and later report the results to the postmaster. Also, postmasters should use the most up-to-date list of manufacturers and mailbox suppliers when providing motorized city, rural, and highway contract box delivery route customers with information about the type of box to install.

— *Delivery Policies and Programs,
Delivery and Retail, 5-16-02*

Exhibit E
Cantilever Mailbox Supports

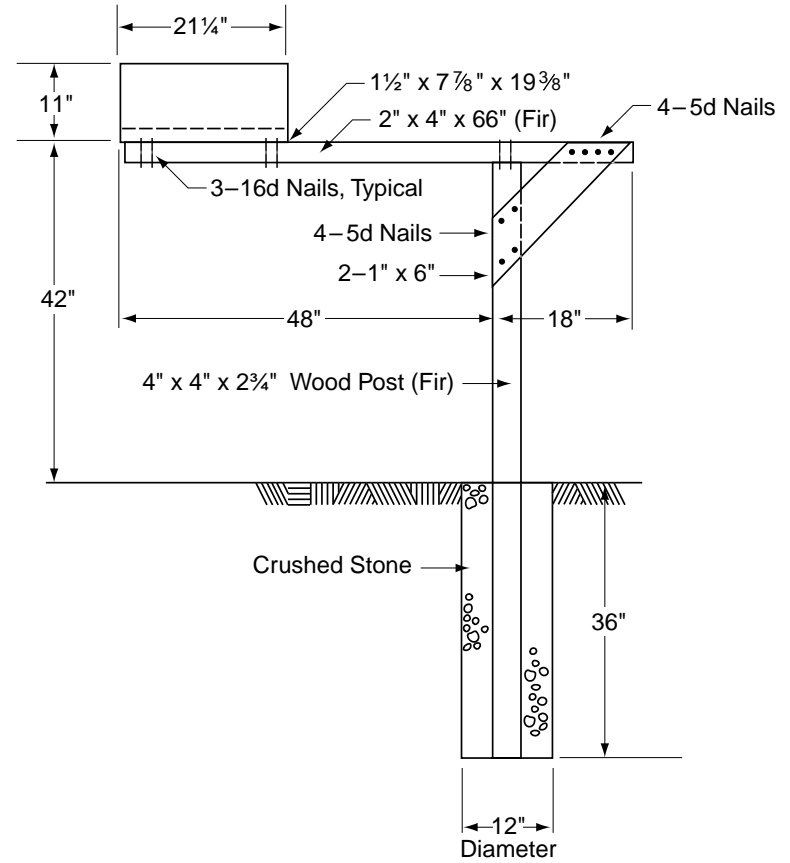
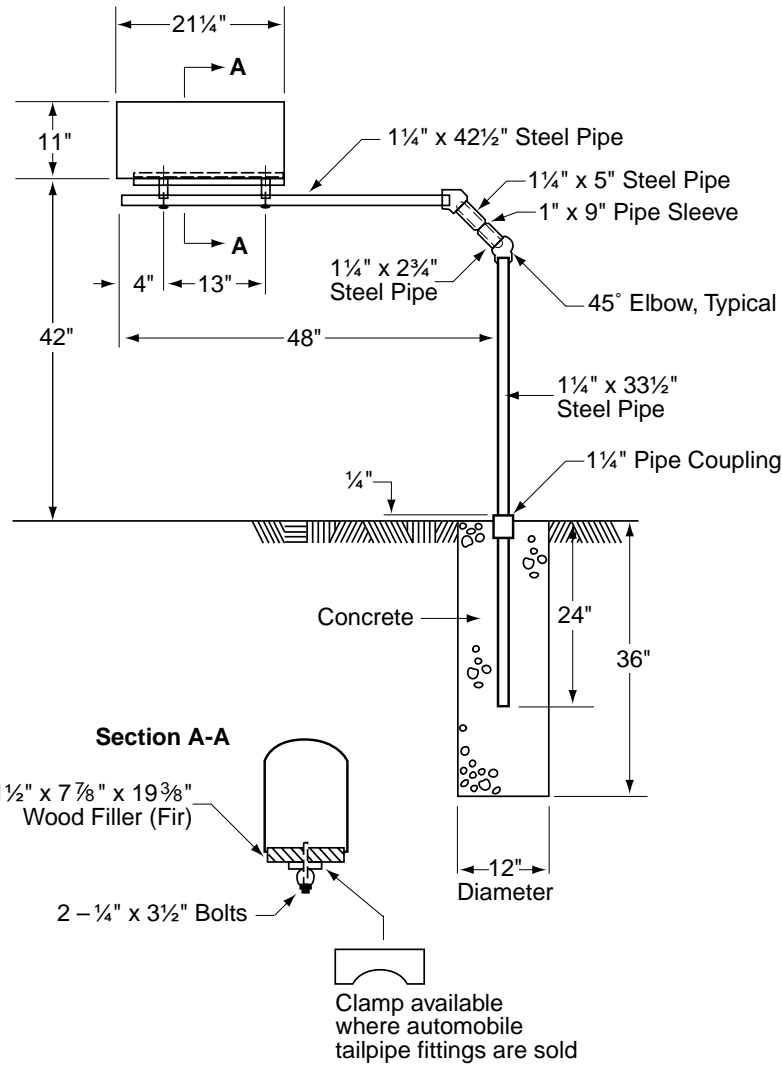
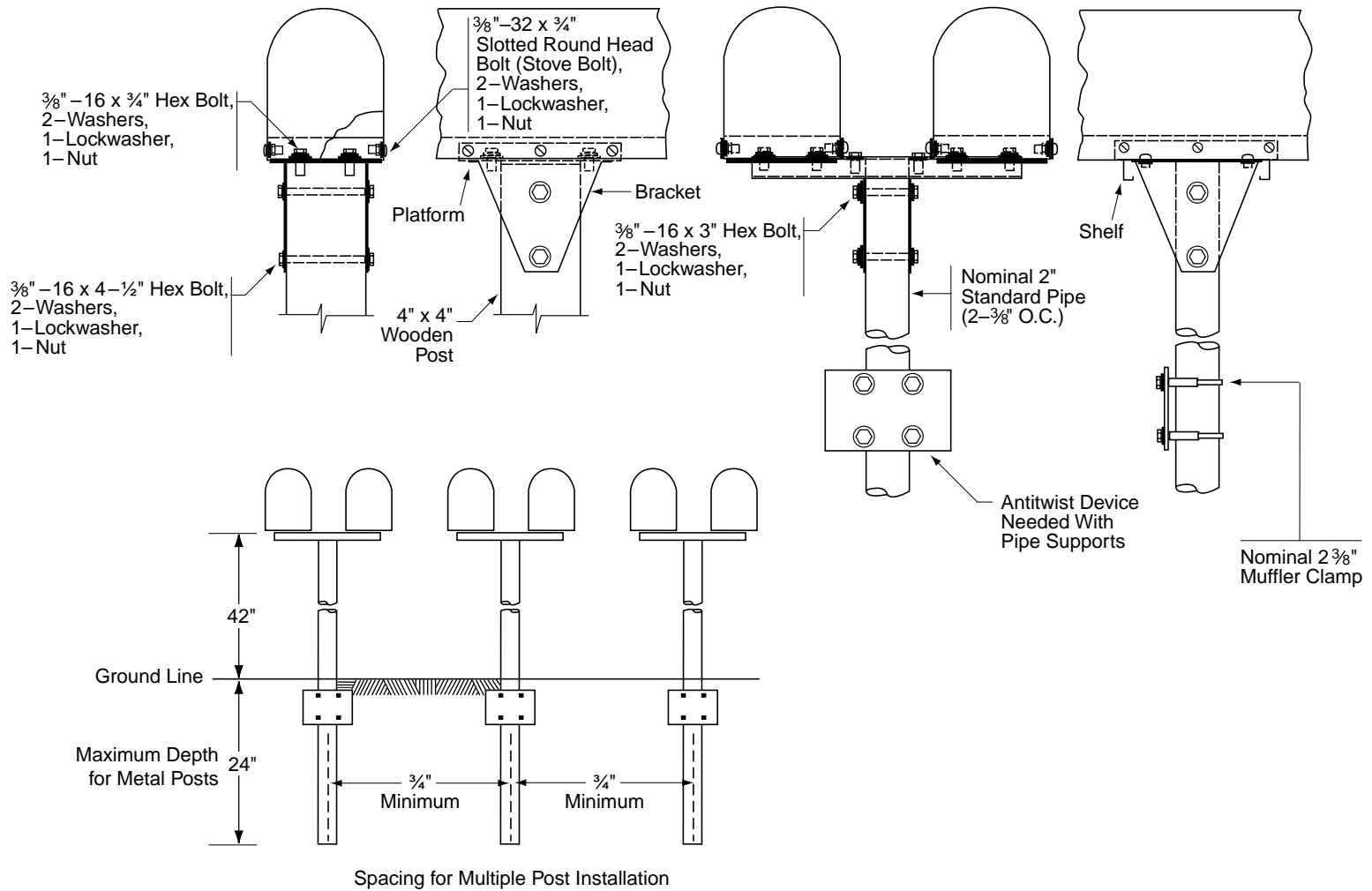

Exhibit F
Single and Double Mailbox Installations





**"Dad, you always make me buckle up.
Why didn't you?"**

Always buckle up

**SAFETY
DEPENDS
ON ME!**

UNITED STATES
POSTAL SERVICE



POSTAL NEWS

FOR IMMEDIATE RELEASE
[INSERT DATE]

Contact: [INSERT YOUR NAME]
[INSERT YOUR PHONE NUMBER]
Internet: www.usps.com

Mailbox Improvement Week Arrives in Time for Spring Cleaning

The U.S. Postal Service is asking all [CITY NAME] homeowners to inspect and repair their mailboxes during Mailbox Improvement Week, May 20–25, says Postmaster [FULL NAME].

“Repairing suburban and rural mailboxes improves the appearance of our community and makes delivering and receiving mail safer for our carriers and customers,” [LAST NAME] says.

The Postal Service makes this annual request because of the wear and tear that occurs to mailboxes every year. “This is especially important after the effects of last winter,” [HE/SHE] adds [IF APPLICABLE].

Some of the typical activities that may need to be done include:

- Replacing loose hinges on a mailbox door.
- Repainting a mailbox that may have rusted or started peeling paint.
- Remounting a mailbox post if loosened.
- Replacing or adding house numbers.

“If a homeowner plans to install a new mailbox or replace a worn one, he or she must use only Postal Service approved traditional or contemporary mailboxes,” said [LAST NAME]. “Customers should be careful when purchasing curbside mail receptacles because the use of unapproved boxes is prohibited. Customers may use a custom-built mailbox, but they must consult with my office to ensure it conforms to guidelines applying to flag, size, strength, and quality of construction.”

For more information on the use of names or numbers on mailboxes, or answers to any other questions, contact Postmaster [FULL NAME] at [PHONE NUMBER] or call your local postmaster at

###



"Dad, all you had to do was wear the seat belt"



He's right.

**SAFETY
DEPENDS
ON ME!**





Artists—Send your Greetings from America by entering the

Graceful Envelope Contest

Transform an ordinary envelope into a work of art!

Fifty hand-addressed and decorated envelopes based on the Greetings from America set of 50 postage stamps will be selected for display at USPS headquarters.

Entries must be postmarked no later than Thursday, August 1, 2002, and must be addressed using hand-executed lettering to:

**THE GRACEFUL ENVELOPE CONTEST
WASHINGTON CALLIGRAPHERS GUILD
BOX 3688
MERRIFIELD VA 22116-3688**

Entries must be processed and delivered through the U.S. Postal Service as First-Class Mail and may not be wrapped in a separate envelope or protective covering.

Entries must be no smaller than 5" x 3.5" and no larger than 7.5" x 5.5" (maximum depth 1/4"). Legibly print your name and complete address on the BACK of the envelope, as entries will not be opened.

Judges will look for creative and attractive interpretations of the theme "Greetings from America," effective use of color and design, and artistic hand lettering. Computerized type and images are not permitted.

There is no entry fee. Artists must be 18 or older and are limited to one entry. Envelopes may be manufactured or hand-made. Only the front will be judged.

The eighth annual Graceful Envelope Contest is sponsored by the U.S. Postal Service and administered by the Washington (DC) Calligraphers Guild. Complete rules and last year's winning envelopes can be viewed at www.calligraphersguild.org



The Washington Calligraphers Guild
www.calligraphersguild.org

Receipt of entries will not be acknowledged; artists will be notified of the final status of their entries in September 2002. Fifty winners will be selected. No prizes will be awarded.

Winning envelopes will be displayed this fall at U.S. Postal Service headquarters in Washington, DC, and on the Internet, and winners will receive certificates. All entries become the property of the Washington Calligraphers Guild for use in publications or exhibitions and will not be returned.

CUT ALONG DOTTED LINE





**Artists—Send your
Greetings from America
by entering the**

Entries must be postmarked no later than Thursday, August 1, 2002, and must be addressed using hand-executed lettering to:

**THE GRACEFUL ENVELOPE CONTEST
WASHINGTON CALLIGRAPHERS GUILD
BOX 3688
MERRIFIELD VA 22116-3688**

Graceful **Envelope Contest**

*Transform an ordinary
envelope into a work of art!*

*Fifty hand-addressed and decorated
envelopes based on the
Greetings from America
set of 50 postage stamps
will be selected for display
at USPS headquarters.*

Entries must be processed and delivered through the U.S. Postal Service as First-Class Mail and may not be wrapped in a separate envelope or protective covering.

Entries must be no smaller than 5" x 3.5" and no larger than 7.5" x 5.5" (maximum depth 1/4"). Legibly print your name and complete address on the BACK of the envelope, as entries will not be opened.

Judges will look for creative and attractive interpretations of the theme "Greetings from America," effective use of color and design, and artistic hand lettering. Computerized type and images are not permitted.

There is no entry fee. Artists must be 18 or older and are limited to one entry. Envelopes may be manufactured or hand-made. Only the front will be judged.

The eighth annual Graceful Envelope Contest is sponsored by the U.S. Postal Service and administered by the Washington (DC) Calligraphers Guild. Complete rules and last year's winning envelopes can be viewed at www.calligraphersguild.org.



The Washington Calligraphers Guild
www.calligraphersguild.org

Receipt of entries will not be acknowledged; artists will be notified of the final status of their entries in September 2002. Fifty winners will be selected. No prizes will be awarded.

Winning envelopes will be displayed this fall at U.S. Postal Service headquarters in Washington, DC, and on the Internet, and winners will receive certificates. All entries become the property of the Washington Calligraphers Guild for use in publications or exhibitions and will not be returned.

Domestic Mail

REMINDER

R2001-1 PAVE Cycle F Testing and Certification

On April 15, 2002, Presort Accuracy, Validation, and Evaluation (PAVE) Cycle F certification testing became available for all presort software developers. Presort software that is certified during Cycle F will support all of the changes required by the R2001-1 rate case.

Timeline

The timeline for the PAVE Cycle F testing and certification process is as follows:

Start of Cycle F	April 15, 2002
Cycle E certifications expire	June 29, 2002
Rate Case Implementation Date	June 30, 2002
Cycle testing fees take effect	July 16, 2002
End of Cycle F	October 15, 2002

PAVE Verifies Presort Accuracy

The PAVE testing and certification process verifies only the presort accuracy of the software. For testing purposes, PAVE supplies the software developers with address files that include all of the necessary information for each address to ensure that the mailpiece is presorted correctly.

PAVE Does Not Verify Address Information

PAVE does not verify the origin of address information or the assignment of addressing components. For PAVE purposes, addressing components such as County ID for In-County eligibility, ZIP+4[®] codes, and line-of-travel or carrier route information are provided to the developer. Some presort products provide this information to its users, while other presort programs rely upon the user to furnish accurate address components.

Because PAVE does not verify how software companies obtain address information, it is the responsibility of the mailer to verify that the address information is correct. The mailer should determine how the software acquires the County ID, ZIP+4 code, and line-of-travel or carrier route information to ensure that the information is correct. Incorrect components could effect the proper presorting of the mail. Consequently, the mail owner could be subject to additional postage.

Fees

In Cycle F, there are changes to the length of time that free testing is available. Cycle F testing is free to those who start and complete testing by July 15, 2002. Presort software developers who begin testing after July 15 or who have not completed testing by that date will be assessed the following fees:

- Test file — initial test (file generation, postage, and handling), \$50.00.
Each additional test requested, \$10.00.
- Certification — results evaluation (presort analysis and documentation review), \$200.00.
Each additional test evaluated, \$25.00.
- Minimum fee per product, \$250.00.

Fees are also assessed in the following situations:

- Any product that has failed electronic testing three times (Gold certification) in any one test category.
- Any product that has failed hardcopy review two times (Gold or Standard certification) in any one test category.

If you would like to arrange for Cycle F testing and certification or if you have any questions call the PAVE department at 800-238-3150 or send an e-mail message to pncsc@email.usps.gov.

— *Business Mail Acceptance,
Marketing Technology and Channel Management, 5-16-02*

DISTRICT MARKETING AND FINANCE MANAGERS

Express Mail Corporate Account (EMCA) — Negative Account Balances

Recent audits have shown that the number of negative balances for Express Mail Corporate Accounts has increased. Procedures for managing Express Mail Corporate Accounts are listed in *Domestic Mail Manual* (DMM) P500.2.0, Corporate Account.

District Marketing managers and Finance managers should review those procedures in the DMM and take appropriate action to eliminate negative balances.

— Revenue and Field Accounting,
Finance, 5-16-02

— Package Services,
Product Development, 5-16-02

CUSTOMER ORDERING INSTRUCTIONS

Postal Service Zone Charts

Effective July 1, 2002, certain 3-digit ZIP Code latitudes and longitudes that are used within the Postal Service zone charts data will be realigned to reflect the proper sectional center facility (SCF) coordinates. In addition, a new 3-digit ZIP Code (398) will be activated.

Customers may order the following media, which include the changes described above:

- Zone Chart Lookup Program:
\$60.00
Available on CD
- Zone Chart Matrix
\$50.00
Available on CD
- Zone Chart Hardcopy
\$20.00
526 pages

Also effective July 1, 2002, the Zone Chart Lookup Program, Zone Chart Matrix, and Zone Chart Hardcopy will be available only as annual subscriptions. With an annual subscription, customers automatically will receive all updates for 12 months (updates are in the same media as the original order).

To order zone charts in any of the media listed above, customers must complete PS Form 8184, *Zone Chart Data & DMM Module L Labeling List Order Form*. Customers may obtain PS Form 8184 by photocopying the form on pages 43–44 of this *Postal Bulletin* or by printing it from the Postal Service Web site at www.usps.com; click on *Forms*, then *All Online PDF Forms in Numeric Order*. They must submit PS Form 8184 along with a check, money order, or credit card information to the address shown on the form. Customers who have questions or need further information may contact the zone chart administrator at the Postal Service National Customer Support Center at 800-238-3150, extension 4473.

If customers wish to obtain individual zone charts at no cost, they may print charts for mail originating from a single 3-digit ZIP Code by accessing Postal Explorer at <http://pe.usps.gov>; click on *Zone Charts*.

— Business Mail Acceptance,
Marketing Technology and Channel Management, 5-16-02



**ZONE CHART DATA &
DMM MODULE L LABELING LIST
ORDER FORM**

Customer Information *(Please print)*

Attention Name

Firm/Customer Name

Complete Street Address, PO Box or Rural and RR Box Apt/Suite #

City or Post Office State ZIP+4

Foreign Country Name *(When applicable)* Area Code Phone Number

Zone Chart Data Subscription

Option 1: **Zone Chart Lookup Program** X \$60.00 = \$

The Zone Chart Lookup Program allows the user to print and/or display a zone chart, to retrieve a zone and/or zone chart, and to create a zone chart text file. Annual subscription includes any data updates for one year. This program runs on any DOS, Windows or OS/2 computer environment and is available on CD-ROM.

Option 2: **Zone Chart Matrix** X \$50.00 = \$

The zone chart data is in a matrix ASCII file and requires a minimum of 2 mega bytes of disk space. This ASCII File has a record length of 2003 bytes. To use this data, the user must write a program or incorporate this data into a program. The annual subscription includes any data updates for one year and is available on CD-ROM.

Option 3: **Zone Chart Hardcopy** X \$20.00 = \$

This is a complete hardcopy of all zone charts; a total of 526 pages.

DMM Module L Labeling List Subscription

Option 4: **Electronic Labeling List** X \$60.00 = \$

Select Option: CD-ROM RIBBS

The electronic labeling list contains Module L of the *Domestic Mail Manual* (DMM) in electronic format. This product is a yearly subscription which includes periodic updates. Updates are mailed as they occur. This product is available to US Postal Service facilities free of charge.

Express Mail Service (Call Customer Service @ 1-800-238-3150 for cost) \$

Total Cost: \$

For Payment Method see reverse side of this form.

NOTE: Customers may receive, free of charge, zone charts for their originating mail from their local post office or at pe.usps.gov. Do not request copies of individual zone charts using this order form.

Customers who need assistance may call Customer Service at 1-800-238-3150. Please allow 10 business days for processing and delivery of all products. For Express Mail orders, please allow 5 business days.

Send check or money order along with order form to the address below. For credit card orders, simply send the order form.

ACCOUNTS RECEIVABLE
NATIONAL CUSTOMER SUPPORT CENTER
UNITED STATES POSTAL SERVICE
6060 PRIMACY PKWY STE 201
MEMPHIS TN 38188-0001

For USPS Use Only
Control Number:
Check Number:

PS Form 8184 Page 2 of 2 May 2002

Payment Method	
Make check or money order Payable to "United States Postal Service"	
<input type="checkbox"/> Tax ID #	<input type="text"/>
<input type="checkbox"/> Check	<input type="checkbox"/> Money Order
<input type="checkbox"/> Discover	<input type="checkbox"/> Diners Club
<input type="checkbox"/> Express Mail Corporate Acct. #	<input type="checkbox"/> Visa
<input type="checkbox"/> Credit Card #	<input type="checkbox"/> American Express
	<input type="text"/>
	<input type="text"/>
	Card expiration date: ____ / ____
Authorized Personnel (please print)	
Signature	
The signature above accepts total responsibility governing the use of this card and agrees to comply with the terms of the issuer.	
Mail To:	
(Complete only if shipping address is different from mailing address)	
Attention	
Company	
Address	
City, State, ZIP+4	

APO/FPO Changes

The following change appears in the APO/FPO table that is also published in its entirety in this *Postal Bulletin* (22076). **Acceptance clerks may contact the Military Postal Service Agency with any questions regarding APO/FPO ZIP Codes, toll free, at 800-810-6098, Monday–Friday, 0730–1630.**

APO/FPO	Action	Effective Date	See Restrictions
APO AE 09347	Activate	Immediately	A,B,B1,C,C1,D,E2,F,F1,H,M,N,R,R1,V,X,Y,Z,Z1
APO AE 09349	Activate	Immediately	A,B,B1,C,C1,D,E2,F,F1,H,M,N,R,R1,V,X,Y,Z,Z1
FPO AE 09725	Add B1	Immediately	B, B1,C
FPO AE 09728	Add B1	Immediately	B, B1,C
APO AP 96405	Activate	Immediately	B, B1, F, V, Z1

— *International Network Operations, Network Operations Management, 5-16-02*

Overseas Military Mail

Mail addressed to or from military post offices overseas is subject to certain conditions or restrictions of mailing regarding content, preparation, and handling. The table below outlines these conditions by APO/FPO ZIP Codes through the use of footnoted mailing restrictions codes, which appear on the page following the table.

Acceptance clerks should use this table with the integrated retail terminal (IRT) or POS ONE terminal to determine whether an APO/FPO ZIP Code is active and

which conditions of mailing apply. **Acceptance clerks may contact the Military Postal Service Agency with any questions regarding APO/FPO ZIP Codes, toll free, at 800-810-6098, Monday–Friday, 0730–1630.**

For Express Mail Military Service (EMMS) availability, all acceptance clerks must refer to the local hardcopy EMMS directory.

Changes from previous listing are in bold type.

Conditions Applied to Mail Addressed to Military Post Offices Overseas

APO/FPO	See Restrictions	APO/FPO	See Restrictions	APO/FPO	See Restrictions
09001	Not Active	09025	Not Active	09049	Not Active
09002	Not Active	09026	Not Active	09050	B-B1-C-D-U
09003	Not Active	09027	Not Active	09051	Not Active
09004	Not Active	09028	B-B1-C-D-U	09052	Not Active
09005	Not Active	09029	Not Active	09053	B-B1-C-D-U
09006	Not Active	09030	Not Active	09054	B-B1-C-D-U
09007	B-B1-C-D-U	09031	B-B1-C-D-U	09055	Not Active
09008	Not Active	09032	Not Active	09056	B-B1-C-D-U
09009	B-B1-C-D-U	09033	B-B1-C-D-U	09057	Not Active
09010	Not Active	09034	B-B1-C-D-U	09058	B-B1-C-D-U
09011	Not Active	09035	Not Active	09059	B-B1-C-D-U
09012	B-B1-C-D-U	09036	B-B1-C-D-U	09060	B-B1-C-D-U
09013	B-B1-C-D-U-Z1	09037	Not Active	09061	Not Active
09014	B-B1-C-D-U	09038	Not Active	09062	Not Active
09015	Not Active	09039	Not Active	09063	B-B1-C-D-L-U
09016	Not Active	09040	Not Active	09064	Not Active
09017	Not Active	09041	Not Active	09065	Not Active
09018	Not Active	09042	B-B1-C-D-U	09066	Not Active
09019	Not Active	09043	Not Active	09067	B-B1-C-D-U
09020	Not Active	09044	Not Active	09068	Not Active
09021	B-B1-C-D-U	09045	B-B1-C-D-U	09069	B-B1-C-D-U
09022	Not Active	09046	B-B1-C-D-U	09070	Not Active
09023	Not Active	09047	Not Active	09071	Not Active
09024	Not Active	09048	Not Active	09072	Not Active

APO/ FPO	See Restrictions	APO/ FPO	See Restrictions	APO/ FPO	See Restrictions
09073	Not Active	09128	B-B1-C-D-U	09183	B-B1-C-D-U
09074	B-B1-C-D-U	09129	Not Active	09184	Not Active
09075	Not Active	09130	Not Active	09185	B-B1-C-D-U
09076	B-B1-C-D-U	09131	B-B1-C-D-U	09186	B-B1-C-D-U
09077	Not Active	09132	Not Active	09187	Not Active
09078	Not Active	09133	Not Active	09188	Not Active
09079	Not Active	09134	Not Active	09189	Not Active
09080	B-B1-C-D-U	09135	Not Active	09190	Not Active
09081	B-B1-C-D-U	09136	B-B1-C-D	09191	Not Active
09082	Not Active	09137	B-B1-C-D-U	09192	Not Active
09083	Not Active	09138	B-B1-C-D-U	09193	Not Active
09084	Not Active	09139	B-B1-C-D	09194	Not Active
09085	Not Active	09140	B-B1-C-D-U	09195	Not Active
09086	B-B1-C-D-U	09141	Not Active	09196	Not Active
09087	Not Active	09142	B-B1-C-D-U	09197	Not Active
09088	Not Active	09143	B-B1-C-D-U	09198	Not Active
09089	B-B1-C-D-U	09144	Not Active	09199	Not Active
09090	B-B1-C-D-U	09145	Not Active	09200	Not Active
09091	Not Active	09146	Not Active	09201	Not Active
09092	Not Active	09147	Not Active	09202	Not Active
09093	Not Active	09148	Not Active	09203	Not Active
09094	B-B1-C-D	09149	Not Active	09204	Not Active
09095	B-B1-C-D-U	09150	Not Active	09205	Not Active
09096	B-B1-C-D-U	09151	Not Active	09206	Not Active
09097	Not Active	09152	Not Active	09207	Not Active
09098	B-B1-C-D-U	09153	Not Active	09208	Not Active
09099	B-B1-C-D-U	09154	B-B1-C-D-U	09209	Not Active
09100	B-B1-C-D-U	09155	Not Active	09210	Not Active
09101	Not Active	09156	Not Active	09211	B-B1-C-D-U
09102	B-B1-C-D-U	09157	Not Active	09212	B-B1-C-D-U-V
09103	B-B1-D-U	09158	Not Active	09213	B-B1-C-D-U
09104	B-B1-C-D-U	09159	Not Active	09214	B-B1-C-D-U
09105	Not Active	09160	Not Active	09215	Not Active
09106	Not Active	09161	Not Active	09216	Not Active
09107	B-B1-C-D-U	09162	Not Active	09217	Not Active
09108	Not Active	09163	Not Active	09218	Not Active
09109	Not Active	09164	Not Active	09219	Not Active
09110	B-B1-C-D-U	09165	B-B1-C-D-U	09220	Not Active
09111	B-B1-C-D-U	09166	B-B1-C-D-U	09221	Not Active
09112	B-B1-C-D-U	09167	Not Active	09222	Not Active
09113	Not Active	09168	Not Active	09223	Not Active
09114	B-B1-C-D-U	09169	B-B1-C-D-U	09224	Not Active
09115	Not Active	09170	Not Active	09225	B-B1-C-D-U
09116	Not Active	09171	Not Active	09226	B-B1-C-D-U
09117	Not Active	09172	B-B1-C-D-U	09227	B-B1-C-D-U
09118	Not Active	09173	B-B1-C-D-U	09228	Not Active
09119	Not Active	09174	Not Active	09229	B-B1-C-D-U
09120	Not Active	09175	B-B1-C-D-U	09230	Not Active
09121	Not Active	09176	Not Active	09231	Not Active
09122	Not Active	09177	B-B1-C-D-U	09232	Not Active
09123	B-B1-C-D-U	09178	Not Active	09233	Not Active
09124	Not Active	09179	Not Active	09234	Not Active
09125	Not Active	09180	B-B1-C-D-U	09235	Not Active
09126	B-B1-C-D	09181	Not Active	09236	Not Active
09127	Not Active	09182	B-B1-C-D-U	09237	B-B1-C-D-U-V

APO/ FPO	See Restrictions	APO/ FPO	See Restrictions	APO/ FPO	See Restrictions
09238	Not Active	09293	Not Active	09339	Not Active
09239	Not Active	09294	Not Active	09340	A-B-B1-C1-F-R-V
09240	Not Active	09295	Not Active	09341	Not Active
09241	Not Active	09296	Not Active	09342	Not Active
09242	Not Active	09297	Not Active	09343	Not Active
09243	Not Active	09298	Not Active	09344	Not Active
09244	B-B1-C-D-U	09299	Not Active	09345	A-B-B1-C1-E2-F-H1-M-N-R- R1-V-Z1
09245	B-B1-C-D-U	09300	Not Active	09346	Not Active
09246	Not Active	09301	Not Active	09347	A-B-B1-C-C1-D-E2-F-F1-H- M-N-R-R1-V-X-Y-Z-Z1
09247	Not Active	09302	B-B1-E2-F-H1-R-R1-U2-V- Z1	09348	Not Active
09248	Not Active	09303	B-B1-E2-F-H1-R-R1-U2-V- Z1	09349	A-B-B1-C-C1-D-E2-F-F1-H- M-N-R-R1-V-X-Y-Z-Z1
09249	Not Active	09304	B-B1-E2-F-H1-R-R1-U2-V- Z1	09350	A-B-B1-C1-E2-F-H1-M-R- R1-V-Z1
09250	B-B1-C-D-U	09305	B-B1-E2-F-H1-R-R1-U2-V- Z1	09351	A-B-B1-C1-E2-F-H1-M-N-R- R1-V-Z1
09251	Not Active	09306	Not Active	09352	A-B-B1-C1-E2-F-H1-M-R- R1-V-Z1
09252	B-B1-C-D-U	09307	Not Active	09353	A-B-B1-C1-E2-F-H1-M-R- R1-V-Z1
09253	Not Active	09308	Not Active	09354	A-B-B1-C1-E2-F-H1-M-N-R- R1-V-Z1
09254	Not Active	09309	A-B-B1-C1-E2-F-H1-M-N-R- R1-V-Z1	09355	A-B-B1-C1-E2-F-H1-M-N-R- R1-V-Z1
09255	Not Active	09310	A-B-B1-C1-E2-F-H1-M-N-R- R1-V-Z1	09356	A-B-B1-C1-E2-F-H1-M-N-R- R1-V-Z1
09256	Not Active	09311	A-B-B1-C1-E2-F-H1-M-R- R1-V-Z1	09357	Not Active
09257	Not Active	09312	Not Active	09358	Not Active
09258	Not Active	09313	Not Active	09359	Not Active
09259	Not Active	09314	B-B1-C-F-V	09360	B-B1-V
09260	Not Active	09315	Not Active	09361	A-B-B1-C1-E2-F-H1-M-N-R- R1-V-Z1
09261	Not Active	09316	A-B-B1-C1-E2-F-H1-M-N-R- R1-V-Z1	09362	A-B-B1-C1-E2-F-H1-M-N-R- R1-V-Z1
09262	B-B1-C-D-U	09317	A-B-B1-C1-E2-F-H1-M-N-R- R1-V-Z1	09363	Not Active
09263	B-B1-C-D-U	09318	A-B-B1-C1-E2-F-H1-M-N-R- R1-V-Z1	09364	A-B1-F-N-R1-Z1
09264	B-B1-C-D-U	09319	Not Active	09365	Not Active
09265	B-B1-C-D-N-U	09320	Not Active	09366	Not Active
09266	B-B1-C-D-U	09321	Not Active	09367	Not Active
09267	B-B1-C-D-U	09322	Not Active	09368	Not Active
09268	Not Active	09323	Not Active	09369	Not Active
09269	Not Active	09324	Not Active	09370	Not Active
09270	Not Active	09325	Not Active	09371	Not Active
09271	Not Active	09326	Not Active	09372	Not Active
09272	Not Active	09327	Not Active	09373	Not Active
09273	Not Active	09328	Not Active	09374	Not Active
09274	Not Active	09329	Not Active	09375	Not Active
09275	Not Active	09330	Not Active	09376	Not Active
09276	Not Active	09331	Not Active	09377	Not Active
09277	Not Active	09332	Not Active	09378	Not Active
09278	Not Active	09333	Not Active	09379	Not Active
09279	Not Active	09334	Not Active	09380	Not Active
09280	Not Active	09335	Not Active	09381	Not Active
09281	Not Active	09336	Not Active	09382	Not Active
09282	Not Active	09337	Not Active		
09283	Not Active	09338	Not Active		
09284	Not Active				
09285	Not Active				
09286	Not Active				
09287	Not Active				
09288	Not Active				
09289	Not Active				
09290	Not Active				
09291	Not Active				
09292	Not Active				

APO/ FPO	See Restrictions	APO/ FPO	See Restrictions	APO/ FPO	See Restrictions
09383	Not Active	09437	Not Active	09491	Not Active
09384	Not Active	09438	Not Active	09492	Not Active
09385	Not Active	09439	Not Active	09493	Not Active
09386	Not Active	09440	Not Active	09494	B-B1-C-C1-U
09387	Not Active	09441	Not Active	09495	Not Active
09388	Not Active	09442	Not Active	09496	B-B1-C-C1-U-V
09389	Not Active	09443	Not Active	09497	Not Active
09390	Not Active	09444	Not Active	09498	B-B1-C-C1-U
09391	Not Active	09445	Not Active	09499	B-B1-C-C1-U
09392	Not Active	09446	Not Active	09500	Not Active
09393	Not Active	09447	B-B1-C-C1-U-V	09501	B-V
09394	Not Active	09448	Not Active	09502	B-V
09395	A-B-B1-C1-E2-F-H1-M-N-R- R1-V-Z1	09449	Not Active	09503	B-V
09396	A-B-B1-F-V	09450	Not Active	09504	B-V
09397	Not Active	09451	Not Active	09505	B-V
09398	Not Active	09452	Not Active	09506	B-V
09399	Not Active	09453	Not Active	09507	B-V
09400	Not Active	09454	B-B1-C-C1-U	09508	B-V
09401	Not Active	09455	Not Active	09509	B-V
09402	Not Active	09456	B-B1-C-C1-U	09510	B-V
09403	Not Active	09457	Not Active	09511	B-N-V-Z
09404	Not Active	09458	Not Active	09512	Not Active
09405	Not Active	09459	B-B1-C-C1-U	09513	Not Active
09406	Not Active	09460	Not Active	09514	Not Active
09407	Not Active	09461	B-B1-C-C1-U	09515	Not Active
09408	Not Active	09462	Not Active	09516	Not Active
09409	B-B1-C-C1-U-V	09463	B-B1-C-C1-U	09517	B-V
09410	Not Active	09464	B-B1-C-C1-U	09518	Not Active
09411	Not Active	09465	Not Active	09519	Not Active
09412	Not Active	09466	Not Active	09520	Not Active
09413	Not Active	09467	Not Active	09521	B-V
09414	Not Active	09468	B-B1-C-C1-U	09522	Not Active
09415	Not Active	09469	B-B1-C-C1-U	09523	Not Active
09416	Not Active	09470	B-B1-C-C1-U	09524	B-V
09417	Not Active	09471	Not Active	09525	Not Active
09418	Not Active	09472	Not Active	09526	Not Active
09419	Not Active	09473	Not Active	09527	Not Active
09420	Not Active	09474	Not Active	09528	Not Active
09421	B-B1-C-C1-U	09475	Not Active	09529	Not Active
09422	Not Active	09476	Not Active	09530	Not Active
09423	Not Active	09477	Not Active	09531	Not Active
09424	Not Active	09478	Not Active	09532	B-V
09425	Not Active	09479	Not Active	09533	Not Active
09426	Not Active	09480	Not Active	09534	B-V
09427	Not Active	09481	Not Active	09535	Not Active
09428	Not Active	09482	Not Active	09536	Not Active
09429	Not Active	09483	Not Active	09537	Not Active
09430	Not Active	09484	Not Active	09538	Not Active
09431	Not Active	09485	Not Active	09539	Not Active
09432	Not Active	09486	Not Active	09540	Not Active
09433	Not Active	09487	Not Active	09541	Not Active
09434	Not Active	09488	Not Active	09542	Not Active
09435	Not Active	09489	Not Active	09543	B-V
09436	Not Active	09490	Not Active	09544	Not Active

APO/ FPO	See Restrictions	APO/ FPO	See Restrictions	APO/ FPO	See Restrictions
09545	B-V	09600	Not Active	09655	Not Active
09546	Not Active	09601	B-B1-C-F-F1-U	09656	Not Active
09547	Not Active	09602	Not Active	09657	Not Active
09548	Not Active	09603	B-B1-C-F-F1-U	09658	Not Active
09549	B-V	09604	B-B1-C-F-F1-U	09659	Not Active
09550	B-V	09605	Not Active	09660	Not Active
09551	Not Active	09606	Not Active	09661	Not Active
09552	Not Active	09607	Not Active	09662	Not Active
09553	Not Active	09608	Not Active	09663	Not Active
09554	B-B1-V	09609	B-B1-C-F-U	09664	Not Active
09555	Not Active	09610	B-B1-C-F-U	09665	Not Active
09556	B-V	09611	Not Active	09666	Not Active
09557	B-V	09612	B-B1-C-F-U	09667	Not Active
09558	Not Active	09613	B-B1-C-F-U-V	09668	Not Active
09559	Not Active	09614	Not Active	09669	Not Active
09560	Not Active	09615	Not Active	09670	Not Active
09561	Not Active	09616	Not Active	09671	Not Active
09562	Not Active	09617	B-B1-C-F-U	09672	Not Active
09563	Not Active	09618	B-B1-C-F-U	09673	Not Active
09564	B-V	09619	B-B1-C-F-U	09674	Not Active
09565	B-V	09620	B-B1-C-F-U	09675	Not Active
09566	B-V	09621	B-B1-C-F-U	09676	Not Active
09567	B-V	09622	B-B1-C-F-U	09677	Not Active
09568	B-V	09623	B-B1-C-F-U	09678	Not Active
09569	B-V	09624	B-B1-C-F-U	09679	Not Active
09570	B-V	09625	B-B1-C-F-U	09680	Not Active
09571	Not Active	09626	B-B1-C-F-U	09681	Not Active
09572	Not Active	09627	B-B1-C-F-U	09682	Not Active
09573	B-V	09628	B-B1-C-F-F1-U-V	09683	Not Active
09574	B-V	09629	Not Active	09684	Not Active
09575	B-V	09630	B-B1-C-F-U-V	09685	Not Active
09576	B-V	09631	B-B1-C-F-U	09686	Not Active
09577	B-V	09632	Not Active	09687	Not Active
09578	B-V	09633	Not Active	09688	Not Active
09579	B-V	09634	Not Active	09689	Not Active
09580	Not Active	09635	Not Active	09690	Not Active
09581	B-V	09636	B-B1-C-F-U	09691	Not Active
09582	B-V	09637	Not Active	09692	Not Active
09583	Not Active	09638	B-B1-C-E2-F-U-V	09693	Not Active
09584	Not Active	09639	Not Active	09694	Not Active
09585	Not Active	09640	Not Active	09695	Not Active
09586	B-V	09641	Not Active	09696	Not Active
09587	B-V	09642	B-B1-N-U	09697	Not Active
09588	B-V	09643	B-B1-U	09698	Not Active
09589	B-B1-V	09644	B-B1-U	09699	Not Active
09590	B-V	09645	B,U	09700	Not Active
09591	B-V	09646	Not Active	09701	Not Active
09592	Not Active	09647	B-B1-N-U	09702	Not Active
09593	B-V	09648	Not Active	09703	B-B1-C-F1
09594	B-V	09649	B-B1-U	09704	B-B1-C-D-V
09595	B-V	09650	Not Active	09705	B-B1-U
09596	B-V	09651	Not Active	09706	B-B1-C-U-V
09597	Not Active	09652	Not Active	09707	B-B1-C-N-U-V
09598	Not Active	09653	Not Active	09708	B-B1
09599	B-V	09654	Not Active	09709	B-B1-F1

APO/ FPO	See Restrictions	APO/ FPO	See Restrictions	APO/ FPO	See Restrictions
09710	B-B1-C-C1-F1-M-R-R1-U	09765	Not Active	09816	Not Active
09711	B-B1-F1-Z1	09766	Not Active	09817	Not Active
09712	Not Active	09767	Not Active	09818	Not Active
09713	B-B1-C-F1	09768	Not Active	09819	A-B-F-P-V-Z1
09714	B-B1-C-C1-F1-M-R-R1-U	09769	Not Active	09820	Not Active
09715	B-B1-F1	09770	Not Active	09821	A-B-F-V-Z1
09716	B-B1-C-D-N-U-V	09771	Not Active	09822	A-B-F-V-Z1
09717	B-B1-M-W	09772	Not Active	09823	A-B-F-V-Z1
09718	B-B1-F-I-N-U-V	09773	Not Active	09824	A-B-F-V-Z1
09719	Not Active	09774	Not Active	09825	Not Active
09720	B-B1-U-V	09775	Not Active	09826	B-B1-E2-E3-F-H1-R-R1-U1-V-Z1
09721	B-B1-N-U-Z1	09776	Not Active	09827	A-B-F-Z1
09722	B-B1-C-D-N-U-V	09777	A-B-B1-C-E1-N	09828	B-N-V-Z1
09723	B-B1-N-U-V-Z1	09778	Not Active	09829	Not Active
09724	B-B1-C-C1-F1-M-R-R1-U	09779	A-B-B1-F-R-V	09830	B-B1-C-Z1
09725	B-B1-C	09780	A-B-B1-F-R-V	09831	B-B1-F-N-U-V-Z1
09726	B-B1-N-U	09781	Not Active	09832	B-B1-U1-V-Z1
09727	Not Active	09782	Not Active	09833	B-B1-U1-V-Z1
09728	B-B1-C	09783	Not Active	09834	B-B1-V-Z1
09729	Not Active	09784	Not Active	09835	A-B-B1-V-Z1
09730	Not Active	09785	Not Active	09836	A-B-B1-C-F-M-V-Z1
09731	Not Active	09786	Not Active	09837	B-B1-V-Z1
09732	B-B1-N-V-Z1	09787	Not Active	09838	B-B1-V-Z1
09733	B-B1-I-V	09788	A-B-B1-F-R-V	09839	A-B-B1-U-V-Z1
09734	Not Active	09789	A-B-B1-F-R-V	09840	Not Active
09735	B-B1-N-V-Z1	09790	A-B-B1-C1-F-R-V	09841	A-B-B1-U-Z1
09736	Not Active	09791	A-B-B1-C1-E1-F-M-R-V	09842	A-B-B1-Z1
09737	Not Active	09792	Not Active	09843	Not Active
09738	Not Active	09793	A-B-B1-F-R-V	09844	A-B-B1-U-V-Z1
09739	Not Active	09794	Not Active	09845	Not Active
09740	Not Active	09795	Not Active	09846	Not Active
09741	Not Active	09796	Not Active	09847	Not Active
09742	Not Active	09797	B-B1-C-D-P-V	09848	Not Active
09743	Not Active	09798	Not Active	09849	Not Active
09744	Not Active	09799	Not Active	09850	Not Active
09745	Not Active	09800	Not Active	09851	Not Active
09746	Not Active	09801	Not Active	09852	B-B1-E2-E3-F-H1-R-R1-U1-V-Z1
09747	Not Active	09802	Not Active	09853	B-B1-E2-F-H1-R-R1-U2-V-Z1
09748	Not Active	09803	B-B1-E2-E3-F-H1-R-R1-U1-V-Z1	09854	Not Active
09749	Not Active	09804	Not Active	09855	B-B1-E2-F-H1-R-R1-U2-V-Z1
09750	Not Active	09805	Not Active	09856	Not Active
09751	Not Active	09806	Not Active	09857	Not Active
09752	Not Active	09807	Not Active	09858	B-B1-E2-E3-F-H1-R-R1-U1-V-Z1
09753	Not Active	09808	Not Active	09859	Not Active
09754	Not Active	09809	Not Active	09860	Not Active
09755	Not Active	09810	Not Active	09861	Not Active
09756	Not Active	09811	B-B1-E2-E3-F-H1-R-R1-U1-V-Z1	09862	Not Active
09757	Not Active	09812	B-B1-E2-E3-F-F1-I-N-R-U-V-Z1	09863	Not Active
09758	Not Active	09813	Not Active	09864	Not Active
09759	Not Active	09814	B-B1-E2-E3-F-F1-I-N-R-U-V-Z1	09865	A-B-B1-V-Z1
09760	Not Active	09815	Not Active		
09761	Not Active				
09762	Not Active				
09763	Not Active				
09764	Not Active				

APO/ FPO	See Restrictions	APO/ FPO	See Restrictions	APO/ FPO	See Restrictions
09866	Not Active	09914	Not Active	09968	Not Active
09867	Not Active	09915	Not Active	09969	Not Active
09868	A-B-B1-U-V-Z1	09916	Not Active	09970	Not Active
09869	Not Active	09917	Not Active	09971	Not Active
09870	Not Active	09918	Not Active	09972	Not Active
09871	B-B1-E2-E3-F-H1-R-R1-U1-V-Z1	09919	Not Active	09973	Not Active
09872	Not Active	09920	Not Active	09974	Not Active
09873	Not Active	09921	Not Active	09975	Not Active
09874	Not Active	09922	Not Active	09976	Not Active
09875	Not Active	09923	Not Active	09977	Not Active
09876	Not Active	09924	Not Active	09978	Not Active
09877	Not Active	09925	Not Active	09979	Not Active
09878	Not Active	09926	Not Active	09980	Not Active
09879	Not Active	09927	Not Active	09981	Not Active
09880	B-B1-E2-F-H1-R-R1-U2-V-Z1	09928	Not Active	09982	Not Active
09881	Not Active	09929	Not Active	09983	Not Active
09882	B-B1-E2-E3-F-H1-R-R1-U1-V-Z1	09930	Not Active	09984	Not Active
09883	Not Active	09931	Not Active	09985	Not Active
09884	Not Active	09932	Not Active	09986	Not Active
09885	Not Active	09933	Not Active	09987	Not Active
09886	Not Active	09934	Not Active	09988	Not Active
09887	Not Active	09935	Not Active	09989	Not Active
09888	B-B1-E2-F-H1-R-R1-U2-V-Z1	09936	Not Active	09990	Not Active
09889	B-B1-E2-F-H1-R-R1-U2-V-Z1	09937	Not Active	09991	Not Active
09890	B-B1-E2-F-H1-R-R1-U2-V-Z1	09938	Not Active	09992	Not Active
09891	Not Active	09939	Not Active	09993	Not Active
09892	A-B-B1-F-N-R-R1-V-Z1	09940	Not Active	09994	Not Active
09893	Not Active	09941	Not Active	09995	Not Active
09894	Not Active	09942	Not Active	09996	Not Active
09895	Not Active	09943	Not Active	09997	Not Active
09896	Not Active	09944	Not Active	09998	Not Active
09897	Not Active	09945	Not Active	09999	Not Active
09898	B-B1-E2-F-H1-I-R-R1-U2-V-Z1	09946	Not Active	34000	Not Active
09899	Not Active	09947	Not Active	34001	Not Active
09900	Not Active	09948	Not Active	34002	B-B1-N-U-Z1
09901	Not Active	09949	Not Active	34003	Not Active
09902	Not Active	09950	Not Active	34004	Not Active
09903	Not Active	09951	Not Active	34005	Not Active
09904	Not Active	09952	Not Active	34006	Not Active
09905	Not Active	09953	Not Active	34007	Not Active
09906	Not Active	09954	Not Active	34008	Not Active
09907	Not Active	09955	Not Active	34009	Not Active
09908	Not Active	09956	Not Active	34010	Not Active
09909	Not Active	09957	Not Active	34011	Not Active
09910	Not Active	09958	Not Active	34012	Not Active
09911	Not Active	09959	Not Active	34013	Not Active
09912	Not Active	09960	Not Active	34014	Not Active
09913	Not Active	09961	Not Active	34015	Not Active
		09962	Not Active	34016	Not Active
		09963	Not Active	34017	Not Active
		09964	Not Active	34018	Not Active
		09965	Not Active	34019	Not Active
		09966	Not Active	34020	B-B1-M-N-V-Z1
		09967	Not Active	34021	B-M-N-V-Z1

APO/ FPO	See Restrictions	APO/ FPO	See Restrictions	APO/ FPO	See Restrictions
34022	B-B1-D-F-M-N-V-Z1	34077	Not Active	96232	Not Active
34023	B-B1-M-N-V-Z1	34078	B-B1-F1-N-V-Z1	96233	Not Active
34024	B-B1-M-N-V-Z1	34079	B-B1-F1-N-V-Z1	96234	Not Active
34025	B-B1-F-N-U-V-Z1	34080	Not Active	96235	Not Active
34026	Not Active	34081	Not Active	96236	Not Active
34027	Not Active	34082	Not Active	96237	Not Active
34028	Not Active	34083	Not Active	96238	Not Active
34029	Not Active	34084	Not Active	96239	Not Active
34030	B-B1-M-N-V-Z1	34085	Not Active	96240	Not Active
34031	B-B1-M-N-V-Z1	34086	Not Active	96241	Not Active
34032	B-M-N-V-Z1	34087	Not Active	96242	Not Active
34033	B-C-F-M-N-V-Z1	34088	Not Active	96243	Not Active
34034	B-B1-M-N-V-Z1	34089	Not Active	96244	Not Active
34035	B-B1-H-M-N-V-Z1	34090	B-V	96245	Not Active
34036	B-M-N-V-Z1	34091	B-V	96246	Not Active
34037	B-B1-C-F-H-I-M-N-V-Z1	34092	B-V	96247	Not Active
34038	B-B1-M-N-V-Z1	34093	B-V	96248	Not Active
34039	B-N-V-Z1	34094	Not Active	96249	Not Active
34040	B-V-Z1	34095	B-V	96250	Not Active
34041	B-B1-M-N-U-V-Z1	34096	Not Active	96251	A-B-B1-U
34042	B-B1-D-F-M-N-V-Z1	34097	Not Active	96252	Not Active
34043	B-B1-D-F-M-N-V-Z1	34098	B-V	96253	Not Active
34044	Not Active	34099	B-V	96254	Not Active
34045	Not Active	96200	Not Active	96255	Not Active
34046	Not Active	96201	A-B	96256	Not Active
34047	Not Active	96202	A-B1-U-V	96257	A-B-B1-U
34048	Not Active	96203	A-B	96258	A-B-B1-U
34049	Not Active	96204	A-B-B1	96259	A-B-B1-U
34050	B-V	96205	A-B-B1-U	96260	A-B-B1-U
34051	B-V-Z1	96206	A-B-B1-U	96261	Not Active
34052	Not Active	96207	A-B-B1-V	96262	A-B-B1-U-V
34053	B-V-Z1	96208	A-B-B1-U	96263	Not Active
34054	Not Active	96209	Not Active	96264	A-B-B1-U
34055	B-N-V-Z1	96210	Not Active	96265	Not Active
34056	Not Active	96211	Not Active	96266	A-B-B1-U
34057	Not Active	96212	A-B-B1-U	96267	A-B-B1-U-V
34058	B-B1-V-Z1	96213	A-B-B1-U-V	96268	Not Active
34059	Not Active	96214	A-B-B1-U	96269	A-B-B1-U
34060	Not Active	96215	A-B-B1-U-V	96270	Not Active
34061	Not Active	96216	Not Active	96271	A-B-B1-U
34062	Not Active	96217	A-B-B1-U-V	96272	Not Active
34063	Not Active	96218	A-B-B1-U	96273	Not Active
34064	Not Active	96219	A-B-B1-U-V	96274	Not Active
34065	Not Active	96220	A-B-B1-U-V	96275	A-B-B1-V
34066	Not Active	96221	A-B-B1-U-V	96276	A-B-B1
34067	Not Active	96222	Not Active	96277	Not Active
34068	Not Active	96223	Not Active	96278	A-B-B1-U
34069	Not Active	96224	A-B-B1-U	96279	Not Active
34070	Not Active	96225	Not Active	96280	Not Active
34071	B-I-M-N-V-Z	96226	Not Active	96281	Not Active
34072	Not Active	96227	Not Active	96282	Not Active
34073	Not Active	96228	Not Active	96283	A-B-B1-U
34074	Not Active	96229	Not Active	96284	A-B-B1-U-V
34075	Not Active	96230	Not Active	96285	Not Active
34076	B-B1-F1-N-V-Z1	96231	Not Active	96286	Not Active

APO/ FPO	See Restrictions	APO/ FPO	See Restrictions	APO/ FPO	See Restrictions
96287	Not Active	96342	Not Active	96397	Not Active
96288	Not Active	96343	B-B1-M-W	96398	Not Active
96289	Not Active	96344	Not Active	96399	Not Active
96290	Not Active	96345	Not Active	96400	Not Active
96291	Not Active	96346	Not Active	96401	B-B1-F-V
96292	Not Active	96347	B-B1-F-F1-F2-M-W	96402	B-B1-F-V
96293	Not Active	96348	B-B1-F-F1-F2-M-W	96403	A-B-B1-M-N-U-V
96294	Not Active	96349	B-B1-F-F1-F2-M-W	96404	Not Active
96295	Not Active	96350	B-B1-F-F1-F2-M-W	96405	B-B1-F-V-Z1
96296	Not Active	96351	B-B1-F-F1-F2-M-W	96406	Not Active
96297	A-B-B1-U	96352	Not Active	96407	Not Active
96298	Not Active	96353	Not Active	96408	Not Active
96299	Not Active	96354	Not Active	96409	Not Active
96300	Not Active	96355	Not Active	96410	Not Active
96301	Not Active	96356	Not Active	96411	Not Active
96302	Not Active	96357	Not Active	96412	Not Active
96303	Not Active	96358	Not Active	96413	Not Active
96304	Not Active	96359	Not Active	96414	Not Active
96305	Not Active	96360	Not Active	96415	Not Active
96306	B-B1-F-F1-F2-M-W	96361	Not Active	96416	Not Active
96307	Not Active	96362	B-B1-F-F1-F2-M-W	96417	Not Active
96308	Not Active	96363	Not Active	96418	Not Active
96309	B-B1-M-V-W	96364	Not Active	96419	Not Active
96310	B-B1-M-W	96365	B-B1-M-V-W	96420	Not Active
96311	B-B1-M-V-W	96366	Not Active	96421	Not Active
96312	Not Active	96367	B-B1-L-M-W	96422	Not Active
96313	B-B1-F-F1-F2-M-W	96368	B-B1-M-W	96423	Not Active
96314	Not Active	96369	Not Active	96424	Not Active
96315	Not Active	96370	B-B1-F-F1-F2-M-W	96425	Not Active
96316	Not Active	96371	Not Active	96426	Not Active
96317	Not Active	96372	B-B1-M-W	96427	Not Active
96318	Not Active	96373	B-B1-M-W	96428	Not Active
96319	B-B1-M-W	96374	B-B1-M-W	96429	Not Active
96320	Not Active	96375	B-B1-M-W	96430	Not Active
96321	B-B1-F-F1-F2-M-W	96376	B-B1-M-W	96431	Not Active
96322	B-B1-F-F1-F2-M-W	96377	B-B1-M-W	96432	Not Active
96323	B-B1-M-V-W	96378	B-B1-M-W	96433	Not Active
96324	Not Active	96379	B-B1-M-W	96434	Not Active
96325	Not Active	96380	Not Active	96435	Not Active
96326	B-B1-M-W	96381	Not Active	96436	Not Active
96327	Not Active	96382	Not Active	96437	Not Active
96328	B-B1-M-W	96383	Not Active	96438	Not Active
96329	Not Active	96384	B-B1-M-W	96439	Not Active
96330	B-B1-M-W	96385	Not Active	96440	Not Active
96331	Not Active	96386	B-B1-M-W	96441	Not Active
96332	Not Active	96387	B-B1-M-W	96442	Not Active
96333	Not Active	96388	B-B1-M-W	96443	Not Active
96334	Not Active	96389	Not Active	96444	Not Active
96335	Not Active	96390	Not Active	96445	Not Active
96336	B-B1-M-V-W	96391	Not Active	96446	Not Active
96337	B-B1-M-W	96392	Not Active	96447	Not Active
96338	B-B1-M-W	96393	Not Active	96448	Not Active
96339	B-B1-M-V-W	96394	Not Active	96449	Not Active
96340	Not Active	96395	Not Active	96450	Not Active
96341	Not Active	96396	Not Active	96451	Not Active

APO/ FPO	See Restrictions	APO/ FPO	See Restrictions	APO/ FPO	See Restrictions
96452	Not Active	96507	A-B-F-V	96562	Not Active
96453	Not Active	96508	Not Active	96563	Not Active
96454	Not Active	96509	Not Active	96564	Not Active
96455	Not Active	96510	Not Active	96565	Not Active
96456	Not Active	96511	B-B1-I-N-V	96566	Not Active
96457	Not Active	96512	Not Active	96567	Not Active
96458	Not Active	96513	Not Active	96568	Not Active
96459	Not Active	96514	Not Active	96569	Not Active
96460	Not Active	96515	B-B1-F	96570	Not Active
96461	Not Active	96516	Not Active	96571	Not Active
96462	Not Active	96517	B-B1-F-U3-V	96572	Not Active
96463	Not Active	96518	B-B1-V	96573	Not Active
96464	Not Active	96519	Not Active	96574	Not Active
96465	Not Active	96520	B-F-U3-V	96575	Not Active
96466	Not Active	96521	B-F-N	96576	Not Active
96467	Not Active	96522	B-F-N-U	96577	Not Active
96468	Not Active	96523	Not Active	96578	Not Active
96469	Not Active	96524	Not Active	96579	Not Active
96470	Not Active	96525	Not Active	96580	Not Active
96471	Not Active	96526	Not Active	96581	Not Active
96472	Not Active	96527	Not Active	96582	Not Active
96473	Not Active	96528	Not Active	96583	Not Active
96474	Not Active	96529	Not Active	96584	Not Active
96475	Not Active	96530	A-B-B1-H-M-N-U-V	96585	Not Active
96476	Not Active	96531	B-B1-H-M-U-V	96586	Not Active
96477	Not Active	96532	Not Active	96587	Not Active
96478	Not Active	96533	Not Active	96588	Not Active
96479	Not Active	96534	A-B-F	96589	Not Active
96480	Not Active	96535	A-B-B1-F-V	96590	Not Active
96481	Not Active	96536	B-B1-V	96591	Not Active
96482	Not Active	96537	B-B1-V	96592	Not Active
96483	Not Active	96538	B-B1-V	96593	Not Active
96484	Not Active	96539	Not Active	96594	Not Active
96485	Not Active	96540	B-B1-V	96595	B-B1-V
96486	Not Active	96541	B-B1-V	96596	Not Active
96487	Not Active	96542	B-B1-V	96597	Not Active
96488	Not Active	96543	B-B1-P-V	96598	B-B1-V
96489	Not Active	96544	Not Active	96599	B-B1-V
96490	B-B1-V	96545	Not Active	96600	Not Active
96491	Not Active	96546	B-F-U3	96601	B-V
96492	Not Active	96547	B-F-U3-V	96602	B-V
96493	Not Active	96548	A-B-B1-H-M-U	96603	B-V
96494	Not Active	96549	A-B-B1-H-M-U	96604	B-V
96495	Not Active	96550	Not Active	96605	B-O-V
96496	Not Active	96551	A-B-B1-H-M-U	96606	B-V
96497	Not Active	96552	Not Active	96607	B-V
96498	Not Active	96553	A-B-B1-H-M-N-U-V	96608	B-V
96499	Not Active	96554	A-B-B1-H-M-U	96609	B-V
96500	Not Active	96555	B-B1-F-M-V	96610	B-V
96501	Not Active	96556	Not Active	96611	B-V
96502	Not Active	96557	B-B1-F-M-V	96612	B-V
96503	Not Active	96558	B-V	96613	B-B1-C1-E2-F-H1-I-R1-U2-V-Z1
96504	Not Active	96559	Not Active	96614	B-B1-C1-E2-F-H1-I-R1-U2-V-Z1
96505	Not Active	96560	Not Active		
96506	Not Active	96561	Not Active		

APO/ FPO	See Restrictions	APO/ FPO	See Restrictions	APO/ FPO	See Restrictions
96615	B-V	96644	Not Active	96673	B-V
96616	Not Active	96645	Not Active	96674	B-V
96617	B-V	96646	Not Active	96675	B-V
96618	Not Active	96647	Not Active	96676	B-V
96619	B-V	96648	Not Active	96677	B-V
96620	B-V	96649	Not Active	96678	B-V
96621	B-V	96650	Not Active	96679	B-V
96622	B-V	96651	Not Active	96680	Not Active
96623	B-V	96652	Not Active	96681	B-V
96624	B-V	96653	Not Active	96682	B-V
96625	Not Active	96654	Not Active	96683	B-V
96626	Not Active	96655	Not Active	96684	B-V
96627	Not Active	96656	Not Active	96685	Not Active
96628	B-V	96657	B-V	96686	B-V
96629	B-V	96658	Not Active	96687	B-V
96630	Not Active	96659	Not Active	96688	Not Active
96631	Not Active	96660	B-V	96689	Not Active
96632	Not Active	96661	B-V	96690	Not Active
96633	Not Active	96662	B-V	96691	Not Active
96634	B-V	96663	B-V	96692	Not Active
96635	B-V	96664	B-V	96693	Not Active
96636	Not Active	96665	B-V	96694	Not Active
96637	Not Active	96666	B-V	96695	Not Active
96638	Not Active	96667	B-V	96696	Not Active
96639	Not Active	96668	B-V	96697	Not Active
96640	Not Active	96669	B-V	96698	B-V
96641	Not Active	96670	B-V	96699	Not Active
96642	Not Active	96671	B-V		
96643	B-V	96672	B-V		

RESTRICTIONS

LEGEND

PS Form 2976, *Customs - CN 22 (Old C 1) and Sender's Declaration* (green label)

PS Form 2976-A, *Customs Declaration and Dispatch Note*

AAFES	= Army and Air Force Exchange Service
APO	= Army/Air Force Post Office
Box R	= Retired military personnel
FPO	= Fleet Post Office
DMM	= <i>Domestic Mail Manual</i>
MOM	= Military Ordinary Mail
MPO	= Military Post Office
PAL	= Parcel Airlift
PSC	= Postal Service Center
SAM	= Space Available Mail
USDA	= United States Department of Agriculture

Note: Mail order catalogs are prohibited as SAM or PAL mail.

A. Securities, currency, or precious metals in their raw, unmanufactured state are prohibited. Official shipments are exempt from this restriction.

B. PS Form 2976-A is required for all mail weighing 16 ounces or more, with exceptions noted below. In addition, mailers must properly complete required customs documentation when mailing any potentially dutiable mail addressed to an APO or FPO regardless of weight. The following are exceptions to the requirement for customs documentation on nondutiable mail that weighs 16 ounces or more:

- Known mailers are exempt from providing customs documentation on non-dutiable letters, and printed matter weighing 16 ounces or more. (A known mailer is anyone who legally applies a permit imprint to a mailpiece. Mail with meter postage is not considered to be from a known mailer.)
- All federal, state, and local government agencies are exempt from providing customs documentation on mail addressed to an APO or FPO, except for those APOs/FPOs to which restriction B2 applies.
- Prepaid mail from military contractors is exempt, providing the mailpiece is endorsed "Contents for Official Use — Exempt from Customs Requirements."

B1. PS Form 2976 or 2976-A is required. Articles are liable for customs duty and/or purchase tax unless they are bona fide gifts intended for use by military personnel or their dependents. When the contents of a parcel meet these requirements, the mailer must endorse the customs form, "Certified to be a bona fide gift, personal effects, or items for personal use of military personnel and dependents," under the heading, Description of Contents. **Exceptions:** All other exceptions listed in restriction B above are applicable to this restriction.

B2. All federal, state, and local government agencies must complete customs documentation when sending mail addressed to or from this APO or FPO weighing 16 ounces or more.

C. Cigarettes and other tobacco products are prohibited.

C1. Obscene articles, prints, paintings, cards, films, videotapes, etc., and horror comics and matrices are prohibited.

D. Coffee is prohibited.

E1. Medicines or vaccines not conforming to French laws are prohibited.

E2. Any matter containing religious materials contrary to Islamic faith or depicting nude or seminude persons, pornographic or sexual items, or nonauthorized political materials is prohibited.

E3. Radio transceivers, cordless telephones, global positioning systems, scanners, base stations, and handheld transmitters are prohibited.

F. Firearms of any type are prohibited in all classes of mail. See definitions of firearms in DMM C024.1.1C. This restriction does not apply to firearms mailed to or by official U.S. government agencies.

F1. Privately owned weapons addressed to an individual are prohibited in any class of mail.

F2. Importation of firearms is restricted to one shotgun and one single shot .22 caliber rifle per individual.

G. Only First-Class Mail letters, Periodicals, and Standard Mail items are authorized.

H. Meats, including preserved meats, whether hermetically sealed or not, are prohibited.

H1. Pork or pork by-products are prohibited.

I. Mail of all classes must fit in a mail sack. Mail may not exceed the following dimensions:

Length	42" 72" length and girth combined
	over 42" to 44" 24" girth
	over 44" to 46" 20" girth
	over 46" to 48" 16" girth
	Maximum length 48"

This restriction does not apply to registered mail and official government mail marked MOM.

I1. This restriction does not apply to registered mail.

I2. This restriction does not apply to official government mail marked MOM.

J. Parcels may not exceed 108 inches in length and girth combined.

K. Mail that includes in the address the words, "Dependent Mail Section," may consist only of letter mail, newspapers, magazines, and books. No parcel of any class containing any other matter may be mailed to the Dependent Mail section. This restriction does not apply if the address does not include the words "Dependent Mail Section."

L. All official mail is prohibited.

M. Fruits, animals, and living plants are prohibited.

N. Registered mail is prohibited.

O. Personal mail addressed to vessels using this number is limited to unregistered First-Class Mail items and certified mail. Other classes of mail are prohibited.

P. APO is used for the receipt and dispatch of official mail only.

Q. Mail may not exceed 66 pounds, and size is limited to 42 inches maximum length and 72 inches maximum length and girth combined.

R. All alcoholic beverages, including those mailable under DMM C021, are prohibited.

R1. Materials used in the production of alcoholic beverages (i.e., distilling material, hops, malts, yeast, etc.) are prohibited.

T. Mailings of case lots of food and supplemental household shipments must be approved by the sender's parent agency prior to mailing.

U. Parcels must weigh less than 16 ounces when addressed to Box R. This restriction does not apply to mail endorsed "Free Matter for the Blind or Handicapped."

U1. Mail is limited to First-Class Mail weighing 13 ounces or less when addressed to Box R. This restriction does not apply to mail endorsed "Free Matter for the Blind or Handicapped." Videotapes are prohibited when addressed to Box R, regardless of weight.

U2. Mail is limited to First-Class Mail letters only when addressed to Box R.

U3. Mail is limited to First-Class Mail correspondence (including voice and video cassettes), newspapers, magazines, photographs, not exceeding 16 ounces, when addressed to Box R.

V. Express Mail Military Service (EMMS) not available from any origin.

W. Meat products, such as dried beef, salami, and sausage, may be mailed, provided they remain in their original, hermetically sealed packages and bear USDA certification. Other meats, bones, skin, hair, feathers, horns or hoofs of hoofed animals, wool samples, tobacco leaves, including chewing and pipe tobacco, snuff, cigars, and cigarettes, or obscene material, including obscene drawings, photographs, films, and carvings, are prohibited. Exception: 200 grams of tobacco per parcel are permitted duty free.

X. Personal mail is limited to First-Class Mail items (to include audio cassettes and voice tapes) weighing 13 ounces or less. This limitation does not apply to official mail.

Y. Mail is limited to First-Class and Priority Mail items only. All Periodicals, Standard Mail items, and Package Services items (including SAM and PAL) are not authorized. This restriction also applies to official mail.

Z. No outside pieces (OSPs).

Z1. The Anti-Pilferage Seal (Item No O818-A) is required on all pouches and sacks.



This office
will be closed
Monday,
May 27, 2002,
to observe
Memorial Day.

CUT ALONG DOTTED LINE





This office
will be closed
Monday,
May 27, 2002,
to observe
Memorial Day.



This office
will be closed
Thursday,
July 4, 2002,
to celebrate
Independence Day.

CUT ALONG DOTTED LINE





This office
will be closed
Thursday,
July 4, 2002,
to celebrate
Independence Day.



This office
will be closed
Thursday,
July 4, 2002,
to celebrate
Independence Day.

CUT ALONG DOTTED LINE





This office
will be closed
Thursday,
July 4, 2002,
to celebrate
Independence Day.

Fraud Alert

ALL PERSONNEL PROCESSING MAIL FOR DISPATCH ABROAD

Foreign Order No. 461

Keep all foreign order notices for use as reference.

Tentative Orders

A Tentative Lottery Order has been issued against the following:

Australia

CASH AWARD CENTRE
 AND
 WORLDWIDE WINNERS' SEARCH CENTER
 PSD PROMPT SERVICE DEPT
 PO BOX 5753
 GOLD COAST MAIL CENTRE
 QLD 9726
 AUSTRALIA
 AND AT
 PO BOX 6944
 GOLD COAST MAIL CENTRE
 QLD 9726
 AUSTRALIA
 AND AT
 PO BOX 6688
 GOLD COAST MAIL CENTRE
 QLD 9726
 AUSTRALIA
 AUSTRALIAN LOTTERY WINNERS SERVICE
 AND
 ALWS
 AND
 PDS PROMPT SERVICE DEPT
 PO BOX 5753
 GOLD COAST MAIL CENTRE
 QLD 9726
 AUSTRALIA
 AND AT

PO BOX 6688
 GOLD COAST MAIL CENTRE
 QLD 9726
 AUSTRALIA

Canada

REWARD PAYMENT SYSTEMS
 280 PROGRESS AVENUE
 PO BOX 745
 AGINCOURT ON M1S 5R2
 CANADA
 AUSTRALIAN LOTTERY WINNERS SERVICE
 AND
 ALWS
 AND
 PDS PROMPT SERVICE DEPT
 PO BOX 94730
 STN MAIN
 RICHMOND BC V6Y 4A5
 CANADA

Do not dispatch any mail to the above. Place the mail pieces in a pouch endorsed "Foreign Order Mail" and send it to:

POSTMASTER
 CLAIMS AND INQUIRY
 JAMES A FARLEY BUILDING RM 2029A
 NEW YORK NY 10199-9652

Do not place any endorsement on the mail pieces themselves.

Personnel may post this notice at the outgoing primary. They must post it on the Foreign Order Board at all Processing and Distribution Plants, designated international exchange offices, and Customer Service Plants.

— Judicial Officer, 5-16-02

Withholding of Mail Orders

Withholding of Mail orders are enforced by postmasters at the cities listed below.

State/City/ZIP Code	Names and Addresses Covered
CA, Tustin 92781-1335	Haynes And All Other Names, P.O. Box 1335
NJ, Wildwood 08260-3929	The Surnames Shlapak And Vigulis, 7011 Pacific Avenue, Apt. 10

— Recorder's Office, Judicial Officer, 5-16-02

Table with 14 columns of numerical data, containing postal codes and their corresponding values. Includes bolded entries like 402030, 600006, 701026, 503003, and 800085.

805389	843003	891771	904755	911336	921123	924535	940747	951160	980162	995215	995627	997167
805440	843042	891834	904782	912255	921201	924690	940845	951372	980226	995217	995636	997168
805443	844082	891868	904784	912451	921301	925033	940948	951619	980268	995221	995661	997183
805518	844114	895053	906004	913030	921314	925137	941154	951654	980420	995232	995668	997212
805547	844210	895067	906306	913351	921347	925182	941221	951917	980797	995235	995674	997216
806096	846037	895073	906451	913449	921350	926065	941319	951932	980900	995238	995677	997221
808008	846154	898085	906478	913760	921363	926198	941369	953357	980930	995248	995678	997229
809170	846166	900025	906829	913942	921369	926200	941454	954470	981929	995253	995685	997244
809212	846172	900110	906879	914264	921386	926206	941490	958963	981996	995263	995688	997247
810037	847069	900148	906948	914410	921402	926252	941655	967103	982378	995301	995708	997248
810055	847107	900185	906955	914879	921452	926472	941660	967146	982438	995311	995714	997259
813056	847171	900248	906977	915011	921458	926662	941713	967245	982451	995314	995737	997262
814045	847175	900266	907104	915274	921512	926744	941810	967287	984249	995357	995748	997278
816002	847191	900680	907122	915437	921569	926765	945439	967288	985100	995360	995749	997293
816262	847192	900861	907149	915478	921582	926810	945631	968223	992229	995384	995834	997303
816347	850849	901034	907162	915639	921585	926912	945741	968343	992347	995388	995841	997315
820809	852321	901036	907197	915654	921586	927022	945992	968360	992506	995404	995843	998009
833211	852870	901099	907853	915663	921611	927202	946217	968479	992530	995410	995848	998011
840013	852901	901207	907865	915715	921634	927316	946336	968488	992569	995414	995890	998017
840093	853022	901226	907921	917272	921716	927339	946368	968517	992750	995415	995903	998027
840219	853052	901356	907924	917362	921727	927621	946449	968562	992758	995428	995931	998041
840327	853107	901433	910207	917405	921752	927700	946572	968589	995004	995439	995942	998121
840349	853132	901463	910252	917478	921774	927734	947059	968796	995007	995442	995946	998132
840363	853386	901489	910267	917594	921805	927773	948325	968809	995027	995447	995956	998157
840396	853446	901569	910286	917696	921840	927998	948366	968823	995037	995454	995958	998177
840441	853456	901578	910289	918295	921869	928218	948479	969080	995044	995457	995959	998201
840472	853535	901623	910290	918994	921870	930217	948491	970012	995050	995464	995970	998217
840499	853631	901721	910322	920002	921877	930374	948553	970266	995056	995467	995973	998218
840571	853658	901729	910340	920027	921885	931232	948555	970510	995071	995492	995977	998319
840573	853662	901850	910352	920131	921902	931247	948578	970804	995079	995504	995986	998326
840576	853664	901945	910356	920158	921904	931675	948670	970896	995087	995521	995998	998327
840580	853667	902025	910363	920196	921911	931689	948672	970898	995118	995523	997052	998341
840598	853679	902122	910404	920256	921946	931739	948703	970904	995153	995532	997057	998350
841157	853680	902162	911098	920303	921972	932659	949073	970928	995156	995537	997089	998400
841210	853726	903139	911166	920361	921986	933169	949579	970929	995159	995538	997098	998450
841228	856399	903581	911233	920394	921999	935247	949588	972081	995164	995543	997100	999210
841277	871518	903881	911265	921026	922240	935254	950056	972657	995173	995559	997101	999302
841516	877105	904167	911266	921041	922359	936077	950114	972716	995175	995563	997106	999305
841708	891544	904661	911270	921075	922363	939594	950384	972781	995180	995575	997116	999314
841774	891574	904737	911281	921077	922378	940151	950976	974045	995185	995605	997122	999318
841933	891736	904754	911335	921079	924095	940482	951073	977058	995214	995607	997133	

— Express and Priority Mail, Marketing, 5-16-02

Missing, Lost, or Stolen U.S. Money Order Forms

Do Not Cash — Upon Receipt, Notify Local Postal Inspectors

This listing will be provided to all Postal Service employees responsible for accepting and cashing Postal money orders. All interim notices should be destroyed when the numbers listed appear in the *Postal Bulletin*. The

actual serial numbers consist of the first 10 digits on the money orders. Check for altered dollar amounts by holding money orders to the light.

010 504 1932 to 010 504 1999	026 492 3180 to 026 492 3199	360 168 6008 to 6099	393 650 0074 to 0099
011 582 1889 to 011 582 1899	027 361 0430 to 027 361 0499	360 173 8800 to 8899	393 838 8316 to 8499
011 588 2900 to 011 588 3099	027 369 4482 to 027 369 4495	360 324 2326 to 2399	393 893 6007 to 6099
012 579 5675 to 012 579 5699	027 671 8762 to 027 671 8776	362 861 3064 to 3099	394 126 6907 to 6999
013 289 6176 to 013 289 6199	027 787 9886 to 027 787 9899	373 006 2176 to 2199	394 189 0405 to 0599
013 610 0014 to 013 610 0099	027 965 9487 to 027 965 9499	374 768 2600 to 2699	394 822 3243 to 3278
014 932 1000 to 014 932 1099	028 191 1852 to 028 191 1999	375 169 4400 to 4599	394 990 1810 to 1899
014 972 0800 to 014 972 0899	028 850 3000 to 028 850 3199	375 829 3400 to 3499	395 343 3264 to 3299
015 363 0007 to 015 363 0099	029 510 1500 to 029 510 1599	375 851 9100 to 9199	395 373 3035 to 3099
017 028 3200 to 017 028 3299	030 687 0903 to 030 687 0999	376 196 0911 to 0999	395 396 9649 to 9799
018 569 5333 to 018 569 5399	030 701 3442 to 030 701 3499	378 085 3679 to 3699	395 970 3240 to 3299
018 986 5264 to 018 986 5299	031 077 4507 to 031 077 4799	378 351 1063 to 1099	397 622 4054 to 4099
019 518 2814 to 019 518 2899	032 295 7500 to 032 295 9999	379 843 5100 to 5199	397 819 8902 to 8999
020 698 5159 to 020 698 5199	034 394 1000 to 034 394 1099	380 093 9600 to 9699	398 149 7200 to 7699
020 844 7307 to 020 844 7399	034 943 0400 to 034 943 0799	380 165 1165 to 1199	399 070 0872 to 0899
020 972 8948 to 020 972 8999	040 024 3901 to 040 024 3999	381 325 4500 to 4599	399 156 7119 to 7199
022 021 9110 to 022 021 9181	040 674 7100 to 040 674 7199	381 604 2510 to 2699	399 203 5064 to 5099
022 037 1411 to 022 037 1499	210 221 0548 to 210 221 0599	381 645 9525 to 9599	399 296 9910 to 9999
024 380 4100 to 024 380 4199	227 275 9400 to 227 275 9999	383 314 3968 to 3999	399 396 8935 to 8999
024 496 6870 to 024 496 6896	273 070 8059 to 273 070 8099	383 892 1000 to 1344	399 792 7775 to 7799
025 092 0987 to 025 092 0999	273 775 7700 to 273 775 7899	383 892 1382 to 1399	399 792 8300 to 8399
025 369 5535 to 025 369 5599	302 000 0000 to 302 123 9999	384 925 3641 to 3654	400 427 1051 to 1999
025 729 1151 to 025 729 1199	349 746 2056 to 2099	385 568 2331 to 2399	401 045 1505 to 1549
025 729 1643 to 025 729 1799	350 518 7350 to 7374	385 599 7554 to 7575	401 045 1571 to 1599
	360 011 1690 to 1699	385 774 2024 to 2099	401 294 2700 to 2799
		386 624 1412 to 1599	401 310 9505 to 9599
		386 883 8936 to 8999	401 382 5312 to 5399
		387 314 5574 to 5599	402 578 7876 to 7899
		387 837 6300 to 6399	403 125 6744 to 6799
		388 828 0656 to 0699	403 260 7000 to 7499
		389 696 2400 to 2799	403 280 6470 to 6499
		389 846 3104 to 3135	403 685 8600 to 8699
		389 846 3145 to 3195	404 003 0300 to 0399
		389 887 9211 to 9230	404 041 8838 to 8899
		389 887 9234 to 9299	404 071 4268 to 4299
		390 001 3182 to 3199	404 347 5356 to 5399
		390 001 3500 to 3699	404 347 5548 to 5599
		390 545 5974 to 5999	404 726 4500 to 4599
		391 104 6146 to 6199	404 961 5001 to 5199
		391 574 1466 to 1499	405 325 0188 to 0198
		391 783 3020 to 3599	406 009 4587 to 4599
		391 792 6100 to 6199	406 260 6830 to 6899
		392 668 2956 to 2999	406 459 6641 to 6999
		392 854 8500 to 8899	406 733 3000 to 3999
		393 584 7566 to 7699	407 545 1557 to 1599

407 594 0412 to	0599	422 587 7024 to	7099	450 620 3135 to	3199	462 274 1072 to	1099
407 692 9100 to	9299	422 819 7533 to	7599	450 780 2716 to	2799	462 277 8373 to	8399
407 959 2190 to	2199	422 842 5073 to	5087	450 801 2700 to	2799	462 554 6051 to	6099
408 265 2275 to	2288	422 907 7563 to	7599	451 109 2967 to	2984	463 011 5529 to	5540
408 499 7700 to	7799	424 500 6050 to	6099	451 115 4110 to	4125	463 176 4115 to	4199
408 499 7900 to	7999	424 641 8500 to	8599	451 115 4127 to	4199	463 176 4229 to	4299
408 682 8484 to	8599	424 871 6600 to	6699	451 746 0700 to	0799	463 185 2600 to	2799
408 698 7015 to	7099	425 298 2352 to	2399	452 265 0074 to	0099	463 227 7711 to	7799
409 072 3941 to	3999	425 418 4269 to	4299	452 265 0246 to	0299	463 414 4869 to	4899
410 491 2311 to	2399	425 418 4405 to	4499	452 265 0335 to	0999	463 808 3484 to	3499
410 694 8400 to	8599	426 547 4566 to	4599	452 509 1169 to	1199	463 945 7400 to	7899
410 775 1500 to	1599	427 412 6337 to	6499	452 855 6471 to	6499	464 629 9000 to	9399
410 795 7927 to	7999	427 481 0900 to	0999	452 890 4679 to	4799	464 711 4332 to	4399
410 867 0917 to	0966	428 027 2742 to	2752	452 900 8215 to	8238	465 692 3963 to	3999
410 867 0970 to	0999	429 474 4172 to	4199	453 117 9146 to	9199	465 698 8300 to	8599
411 868 1023 to	1199	429 889 2900 to	2999	453 334 3631 to	3699	465 743 7745 to	7799
411 922 2322 to	2399	430 150 4401 to	4599	453 603 7841 to	7891	466 798 6056 to	6067
412 193 0900 to	0999	430 172 9800 to	9899	453 650 1140 to	1199	467 147 4300 to	4399
412 395 8599 to	8699	430 177 1900 to	2099	453 741 1300 to	1399	468 079 5782 to	5799
412 485 6500 to	6599	430 444 9500 to	9699	454 013 2919 to	2999	469 067 2817 to	2899
412 485 6610 to	6699	430 664 4070 to	4099	454 186 2411 to	2499	469 127 8000 to	8199
412 885 5953 to	5999	432 168 8419 to	8499	454 268 4883 to	4899	469 213 0359 to	0399
414 193 3608 to	3674	432 708 6800 to	6999	454 302 5400 to	5499	469 213 0500 to	0599
414 193 3677 to	3699	432 744 1544 to	1599	454 490 8300 to	8399	469 561 8011 to	8099
414 411 7348 to	7399	432 995 9775 to	9799	454 547 7434 to	7499	469 658 1961 to	1999
414 640 0757 to	0799	433 003 5800 to	5899	454 922 4867 to	4895	469 666 9900 to	9999
414 965 1727 to	1799	433 757 3047 to	3099	455 221 1348 to	1499	469 678 1900 to	1999
417 302 8104 to	8199	433 765 4003 to	4099	455 364 2147 to	2199	469 781 4900 to	4999
417 387 6532 to	6599	434 482 7060 to	7199	455 399 5400 to	5499	469 947 6960 to	6999
417 496 6800 to	6999	434 513 2386 to	2399	455 476 0676 to	0699	470 755 5800 to	5818
417 871 9250 to	9299	434 968 3076 to	3092	455 543 0618 to	0699	471 918 0300 to	0999
417 930 9533 to	9599	435 303 1831 to	1842	456 410 9006 to	9099	471 985 2408 to	2419
418 164 6500 to	6799	435 303 1986 to	1999	456 470 4146 to	4299	472 191 6700 to	6799
418 423 9863 to	9899	435 666 6092 to	6399	456 619 4460 to	4499	472 270 2555 to	2599
418 633 5922 to	5999	436 082 6400 to	6899	457 333 2686 to	2699	472 987 0213 to	0241
418 719 8520 to	8599	436 160 6441 to	6499	457 729 1767 to	1777	472 987 0290 to	0299
418 744 2235 to	2299	437 316 7115 to	7199	457 937 8615 to	8699	473 151 2069 to	2199
418 962 2848 to	2899	437 427 0500 to	3499	458 028 9810 to	9899	473 666 9138 to	9199
419 543 0286 to	0299	439 179 2300 to	2399	458 057 2712 to	2999	473 952 3429 to	3499
419 730 0300 to	0399	439 310 0458 to	0499	458 069 9537 to	9599	474 108 5402 to	5499
420 277 0015 to	0049	440 698 1947 to	1999	458 069 9665 to	9699	474 356 5193 to	5299
420 599 0734 to	0798	440 858 6300 to	6399	458 337 5222 to	5299	474 949 3366 to	3399
420 661 4115 to	4199	440 858 6420 to	7299	458 354 7653 to	7999	475 134 9362 to	9399
420 758 9500 to	9699	441 199 1655 to	1699	458 671 8678 to	8699	475 167 9667 to	9699
420 969 3951 to	3971	443 127 3648 to	3699	458 671 8721 to	8798	475 319 3415 to	3499
420 969 3973 to	3999	443 127 4000 to	4099	458 847 5044 to	5999	475 319 3649 to	3799
421 116 3565 to	3599	443 673 7900 to	7999	459 274 7624 to	7699	475 340 6400 to	6599
421 130 9300 to	9399	443 800 9335 to	9399	459 365 5432 to	5499	475 424 8410 to	8499
421 313 4500 to	4999	444 382 8822 to	8899	459 378 5764 to	5799	475 629 9156 to	9199
421 364 5537 to	5599	444 390 1667 to	1699	459 472 4816 to	4999	475 850 6101 to	6199
421 656 2609 to	2699	444 457 3854 to	3899	460 349 6878 to	6899	475 875 2500 to	2599
421 988 9700 to	9799	450 048 4173 to	4199	460 550 1909 to	1999	476 169 8264 to	8299
422 172 4667 to	4699	450 048 4442 to	4699	460 997 5234 to	5299	476 189 3000 to	3499
422 484 4212 to	4299	450 560 5173 to	5199	461 973 6443 to	6499	476 331 2480 to	2499
422 556 1270 to	1299	450 620 3077 to	3099	462 152 0107 to	0299	477 289 8601 to	8699

477 681 5206 to	5299	491 567 1376 to	1399	609 289 6123 to	6199	628 814 4702 to	4799
478 010 4243 to	4268	492 254 4800 to	4899	609 438 4400 to	4499	628 851 9689 to	9699
478 010 4270 to	4291	492 283 5100 to	5199	609 493 1100 to	1199	629 510 7200 to	7299
478 450 5071 to	5099	492 610 6813 to	6899	609 766 8091 to	8999	629 964 4200 to	4294
478 469 7838 to	7858	493 394 5568 to	5599	609 825 4100 to	4115	630 389 3056 to	3071
478 469 7883 to	7899	493 470 2562 to	2599	609 884 2981 to	2999	630 463 0588 to	0599
479 280 9800 to	9899	493 473 7700 to	7799	609 893 1000 to	1099	631 459 9117 to	9199
479 365 9116 to	9176	493 716 2153 to	2199	610 092 3200 to	3299	631 762 9325 to	9399
479 412 9900 to	9999	494 206 2972 to	2999	610 582 4200 to	4299	632 217 4933 to	4999
479 667 6190 to	6199	494 217 3446 to	3999	611 879 6939 to	6999	632 500 0000 to	599 9999
479 748 9680 to	9699	494 224 0500 to	0599	612 291 8013 to	8099	633 110 4165 to	4199
479 860 7000 to	7199	495 145 0600 to	0699	612 751 5171 to	5199	633 110 4303 to	4499
480 526 2000 to	2099	496 209 7425 to	7499	612 751 5226 to	5299	633 438 6429 to	6599
480 640 6330 to	6399	496 213 8728 to	8799	612 751 6083 to	6099	633 588 7173 to	7182
480 658 0568 to	0599	496 474 5226 to	5248	612 751 6268 to	6299	634 725 0700 to	0799
480 689 5100 to	5199	497 053 8517 to	8699	612 751 6572 to	6599	634 803 3239 to	3299
481 072 9463 to	9499	497 854 8673 to	8699	612 774 2111 to	2199	634 807 2474 to	2499
481 673 0074 to	0095	498 449 8888 to	8899	612 774 2254 to	2299	634 827 5900 to	5999
482 527 1500 to	1599	498 929 8285 to	8499	612 774 2500 to	2599	634 886 3428 to	3499
482 541 5255 to	5299	498 936 5310 to	5399	614 469 0979 to	0999	635 559 3449 to	3499
482 729 6800 to	6899	499 016 5425 to	5499	614 474 3000 to	3099	636 289 6214 to	6299
483 363 7207 to	7299	499 440 8575 to	8899	614 521 3490 to	3499	636 634 8007 to	8042
483 402 2356 to	2399	499 731 6717 to	6799	614 645 1800 to	1899	637 150 1200 to	1299
483 486 5100 to	5199	500 064 1858 to	1869	614 832 1100 to	2099	637 562 5828 to	5899
483 632 1521 to	1599	500 070 5725 to	7799	615 017 7505 to	7599	638 042 1647 to	1699
483 632 2600 to	2799	600 645 3223 to	3299	617 711 6609 to	6699	638 049 4984 to	4999
483 849 1615 to	1699	601 339 1200 to	1399	617 760 5266 to	5299	638 318 1115 to	1199
484 174 4803 to	5299	601 653 5884 to	5899	617 813 3601 to	3699	638 318 1453 to	1499
484 323 8900 to	9199	601 661 7700 to	7799	618 840 9200 to	9299	638 885 0000 to	0299
484 680 5000 to	5038	601 682 5343 to	5399	619 551 7229 to	7299	638 903 4362 to	4373
484 680 5040 to	5074	601 928 1600 to	1699	619 859 3000 to	3099	639 415 1929 to	1999
484 680 5077 to	5099	602 512 2972 to	2999	620 073 9400 to	9499	639 415 2019 to	2099
485 029 4913 to	4999	602 555 2400 to	2799	621 614 7907 to	7930	639 420 6200 to	6299
486 176 0600 to	0699	602 829 7061 to	7099	621 614 7932 to	7999	639 469 3517 to	3799
486 559 7555 to	7599	603 483 9572 to	9599	621 648 8021 to	8199	639 605 2143 to	2199
486 696 3023 to	3199	603 490 7200 to	7299	621 648 8500 to	8599	639 657 8600 to	8799
488 173 7900 to	7999	603 678 7100 to	7199	621 904 8351 to	8599	640 289 7500 to	7599
488 206 4100 to	4199	603 678 7662 to	7699	621 916 1978 to	1989	640 289 7700 to	7999
488 226 0200 to	0299	603 678 7902 to	7999	622 989 8032 to	8099	641 170 4420 to	4499
488 709 3906 to	3999	603 678 8418 to	8499	623 076 9300 to	9399	641 318 3133 to	3199
488 855 8359 to	8399	603 678 8700 to	9999	623 819 5006 to	5099	641 378 6500 to	6999
489 181 8963 to	8999	604 086 0880 to	0899	623 895 8200 to	8399	641 383 8739 to	8799
489 223 2000 to	2099	604 349 1414 to	1499	623 917 0000 to	0099	641 877 3187 to	3299
489 311 1930 to	1999	604 503 7776 to	7799	623 917 0200 to	0299	641 877 3310 to	3399
489 318 6200 to	6300	605 520 9037 to	9099	624 468 5288 to	5299	642 355 8094 to	8199
489 384 0027 to	0099	605 685 4010 to	4099	624 665 3162 to	3198	642 355 8308 to	8999
489 427 0658 to	0899	605 988 6467 to	6499	625 088 6735 to	6799	642 900 0018 to	0099
489 997 5252 to	5299	607 689 7951 to	7960	625 916 9500 to	9799	643 030 6254 to	6299
490 669 5850 to	6099	607 728 1276 to	1299	625 968 8956 to	8999	644 066 0882 to	0899
490 717 7080 to	7099	608 727 7100 to	7199	627 005 3938 to	3999	644 069 0600 to	0699
490 721 6000 to	6099	608 727 7273 to	7599	627 384 3907 to	4099	644 077 7506 to	7699
490 793 1500 to	2099	608 813 9950 to	9999	627 496 7549 to	7599	644 085 8157 to	8199
490 886 8171 to	8199	609 067 5325 to	5399	627 708 3605 to	3699	644 112 9839 to	9899
490 977 9221 to	9240	609 067 5488 to	5499	627 776 2500 to	2599	644 373 9083 to	9099
491 258 8100 to	9099	609 067 5600 to	5699	628 226 3100 to	3199	644 380 1460 to	1499

644 733 4715 to	4799	658 877 8000 to	8199	682 956 6700 to	6799	700 666 1323 to	1349
644 900 9712 to	9799	658 880 8000 to	8199	682 965 1178 to	1199	700 786 9106 to	9142
644 901 0109 to	1299	659 398 7300 to	7399	682 965 1201 to	1299	700 859 0744 to	0758
644 901 1325 to	1399	659 706 8113 to	8199	683 118 2389 to	2399	701 028 6780 to	6899
644 923 6800 to	7799	659 846 7837 to	7899	683 378 2000 to	2099	701 213 3900 to	3999
644 932 4655 to	4699	660 510 4100 to	4199	683 378 2117 to	2299	701 267 2000 to	3999
645 318 7240 to	7499	660 673 0400 to	0599	683 415 1200 to	1499	701 335 7312 to	7399
645 333 1766 to	1799	661 488 5000 to	5099	683 444 8159 to	8199	701 369 2005 to	2050
645 790 8632 to	8699	661 609 9100 to	9199	685 154 7780 to	7789	701 503 2247 to	2299
645 821 0657 to	0699	661 716 9420 to	9499	685 297 7645 to	7699	701 541 2271 to	2299
645 930 7948 to	7999	661 906 6522 to	6599	685 623 5264 to	5299	701 553 6557 to	6599
645 975 0737 to	0762	662 021 8332 to	8399	685 650 9487 to	9499	701 601 3457 to	3499
646 242 6200 to	6299	662 068 0700 to	0899	685 669 4200 to	4299	701 605 5913 to	5999
646 270 7639 to	7799	662 553 0774 to	0799	685 757 8452 to	8499	701 695 3982 to	3999
646 798 4000 to	4999	663 078 7034 to	7099	686 071 2694 to	2799	701 695 4148 to	4199
647 048 7035 to	7099	663 763 5300 to	5399	686 176 3333 to	3354	701 695 4227 to	4299
647 049 2900 to	2999	663 883 7039 to	7499	686 372 3200 to	3299	701 708 1741 to	1799
647 398 8300 to	8399	664 253 8000 to	8499	686 644 5879 to	5899	701 736 3966 to	3999
647 398 8481 to	8499	664 656 3055 to	3099	686 899 1371 to	1399	701 838 2800 to	2899
647 437 3000 to	4999	665 174 6400 to	6499	686 931 7636 to	7699	701 941 0600 to	0699
647 811 2188 to	2199	665 274 8208 to	8299	687 601 0973 to	0999	702 171 1603 to	1699
648 009 6057 to	6099	665 669 5400 to	5499	687 614 6774 to	6799	702 195 5109 to	5199
648 163 5300 to	5499	666 132 8226 to	8299	688 120 9000 to	9999	702 254 9300 to	9399
648 722 5283 to	5299	666 696 2209 to	2299	688 314 3107 to	3191	702 264 7569 to	7599
648 892 3164 to	3199	666 696 2309 to	2399	690 291 1361 to	1371	702 713 1800 to	1809
649 100 3989 to	3999	667 032 9300 to	9399	690 788 2877 to	2899	702 821 5730 to	5799
649 647 0370 to	0399	667 729 5529 to	5599	690 893 5344 to	5399	702 821 5805 to	5899
649 647 0522 to	0599	668 383 8400 to	8699	690 893 5512 to	5599	702 878 0114 to	0199
649 647 5237 to	5399	670 368 3400 to	3499	690 904 1300 to	1599	740 002 7710 to	7719
649 647 9100 to	9299	670 369 7336 to	7399	690 941 6000 to	6199	740 241 9049 to	9099
649 666 7800 to	8299	670 750 7169 to	7199	691 313 6383 to	6399	740 255 1718 to	1799
650 114 7707 to	7719	671 046 6200 to	6399	691 313 6600 to	6699	740 523 7432 to	7449
650 130 3400 to	3599	671 251 5448 to	5499	691 582 8003 to	8099	740 705 9790 to	9799
650 213 0406 to	0499	671 926 5600 to	5799	691 664 1800 to	1999	740 726 6400 to	6500
650 555 1749 to	1799	672 444 2000 to	2999	691 664 2400 to	2499	740 765 3306 to	3399
650 564 1900 to	1999	672 828 3410 to	3499	692 727 9362 to	9399	805 885 8411 to	8499
650 627 4212 to	4299	673 167 5776 to	5799	692 798 1800 to	1899	806 087 1100 to	1499
650 736 2043 to	2099	675 464 3700 to	3799	693 249 0779 to	0799	806 268 9275 to	9299
650 739 1540 to	1699	675 464 4000 to	4199	693 249 0877 to	1699	806 534 3400 to	3477
651 741 4415 to	4499	676 365 5958 to	5999	693 445 0566 to	0999	807 342 3283 to	3399
651 882 2800 to	2899	676 669 1024 to	1099	693 448 8500 to	8999	808 086 7100 to	7199
652 754 6317 to	6399	677 126 6734 to	6799	693 645 9583 to	9599	808 090 3440 to	3499
653 131 4945 to	4999	677 333 9979 to	9999	693 965 4200 to	4299	808 325 5161 to	5699
653 426 3300 to	3399	677 466 1088 to	1099	695 741 2906 to	2999	808 784 8000 to	8299
653 455 4874 to	4899	678 071 4500 to	4799	695 947 8518 to	8599	830 125 0672 to	0699
654 238 0000 to	0399	678 096 7531 to	7599	696 662 8247 to	8299	830 602 5800 to	5999
654 404 3065 to	3092	679 909 2578 to	2599	697 447 8285 to	8296	830 610 3700 to	3799
654 962 2900 to	3199	680 112 9565 to	9599	698 042 4816 to	4899	830 983 3500 to	3599
655 103 5081 to	5199	680 244 0903 to	0999	698 131 2138 to	2157	830 983 3635 to	3699
655 523 2600 to	2999	680 412 6046 to	6099	698 227 0000 to	0099	831 354 1387 to	1399
656 305 2448 to	2499	680 761 6800 to	6899	700 065 2570 to	2599	831 815 8240 to	8299
657 347 4438 to	4999	681 677 0540 to	0699	700 065 4800 to	4899	832 525 3810 to	3899
657 710 8100 to	8999	682 070 1029 to	1099	700 190 3350 to	3359	833 159 1884 to	1899
657 780 0985 to	0999	682 956 6280 to	6299	700 228 6048 to	6099	833 456 2567 to	2599
658 586 1400 to	1499	682 956 6490 to	6599	700 650 0452 to	0499	833 566 3015 to	3071

834 316 5444 to	5499	846 918 0572 to	0599	859 811 2888 to	2899	869 800 0000 to	999 9999
834 354 8747 to	8766	847 237 7690 to	7699	859 855 8873 to	8999	870 054 4814 to	4899
834 354 8824 to	8838	847 284 2481 to	2499	860 240 8520 to	8599	870 491 4812 to	4849
835 269 5700 to	5799	847 374 7055 to	7065	860 275 3900 to	3999	870 536 5820 to	5829
835 496 7303 to	7399	847 374 7055 to	7065	860 518 9629 to	9699	870 541 7167 to	7239
835 539 5200 to	5999	847 636 5304 to	5399	860 600 0021 to	0999	870 575 8155 to	8999
835 813 3015 to	3099	847 700 5447 to	5499	861 158 2350 to	2599	870 589 0485 to	0494
837 672 8967 to	8999	847 723 7500 to	7599	861 637 6010 to	6099	870 691 7060 to	7099
837 784 3282 to	3299	849 485 3427 to	3499	861 979 7292 to	7499	872 100 0445 to	0459
838 176 8377 to	8399	849 608 1357 to	1399	862 216 6100 to	6199	900 556 4178 to	4199
838 518 1257 to	1299	849 792 2600 to	2699	862 263 9213 to	9299	900 845 0044 to	0099
839 718 8257 to	8299	850 546 1862 to	1899	862 271 0800 to	0999	900 936 0217 to	0299
840 323 0600 to	0699	851 143 6826 to	6844	862 271 5000 to	5099	900 936 0435 to	0499
840 875 6235 to	6299	851 209 9880 to	9899	863 871 5138 to	5199	901 058 5255 to	5280
840 910 0900 to	0999	851 928 9221 to	9299	863 949 5300 to	5399	901 273 1082 to	1099
841 349 5000 to	5099	852 589 6560 to	6599	864 088 8200 to	8299	901 287 5143 to	5199
841 805 7747 to	7899	853 049 3646 to	3699	864 426 3972 to	3999	901 291 2789 to	2799
841 805 7944 to	8099	854 304 4089 to	4999	864 520 6117 to	6136	901 525 7122 to	7199
842 226 0685 to	0695	854 529 2200 to	2299	865 151 0526 to	0599	902 198 9769 to	9799
842 685 4600 to	4699	854 532 0000 to	2999	865 500 4034 to	4099	902 948 1269 to	1299
842 685 4742 to	4999	855 001 6204 to	6249	865 883 6082 to	6099	902 985 0833 to	0899
842 860 0300 to	0399	855 319 9364 to	9399	866 004 3000 to	3999	904 600 6523 to	6599
842 898 5582 to	5599	855 361 3390 to	3399	866 442 4100 to	4899	904 892 0378 to	0399
843 062 7100 to	7199	856 226 0490 to	0499	867 366 9108 to	9118	904 892 0648 to	1299
843 077 6288 to	6299	856 656 5800 to	5999	867 633 7403 to	7499	905 056 2216 to	2299
843 077 6378 to	6399	856 752 0200 to	0299	867 737 5623 to	5699	905 794 0000 to	0199
843 758 5769 to	5778	857 279 3450 to	3499	868 169 4529 to	4599	905 794 0288 to	0299
843 786 2554 to	2699	857 843 4000 to	4099	868 173 8400 to	8599	905 873 6900 to	6999
845 656 8165 to	8199	858 124 7644 to	7699	868 514 9000 to	9099	905 873 7100 to	7299
845 727 2100 to	2199	858 756 3111 to	3299	868 566 9200 to	9299	905 880 8900 to	8999
845 746 2618 to	2635	859 063 8200 to	8699	869 387 1150 to	1199	905 885 8411 to	8499
846 390 7531 to	7599	859 190 0600 to	0644	869 505 3500 to	3599	905 889 7100 to	7199

— Postal Inspection Service, 5-16-02

Missing, Lost, or Stolen Canadian Money Order Forms

Do Not Cash — Upon Receipt, Notify Local Postal Inspectors

This listing will be provided to all Postal Service employees responsible for accepting and cashing Postal money orders. Destroy any interim notices when the numbers listed appear in the *Postal Bulletin*. The new money order serial numbers consist of the first 9 digits. The 10th digit is a check digit only.

Do not cash new style money orders **000 000 001 to 692 600 000**. Advise holders to send invalid money orders to: Canada Post Corporation, Ottawa, Canada K1A 0B1. Check for altered dollar amounts by holding money orders to the light.

000 000 001 to 692 600 000	701 945 451 to 5 500	707 958 541 to 8 570	717 193 161 to 3 490
692 720 871 to 0 900	702 033 701 to 4 050	707 960 107 to 0 160	717 228 591 to 8 680
692 876 955 to 7 050	702 051 501 to 1 750	708 059 941 to 60 000	717 333 902 to 3 950
693 290 380 to 0 400	702 053 601 to 3 800	708 115 830 to 5 860	717 739 745 to 9 910
693 290 426 to 0 450	702 104 368 to 4 900	708 116 251 to 6 310	717 884 991 to 5 050
694 063 700 to 3 897	702 128 306 to 8 400	708 138 301 to 8 480	718 026 171 to 6 290
694 063 900 to 4 000	702 179 891 to 9 900	709 222 591 to 2 920	718 466 370 to 6 420
694 550 501 to 0 530	702 260 751 to 0 850	709 243 479 to 3 500	718 568 451 to 8 479
694 595 031 to 5 050	702 410 595 to 1 050	709 411 171 to 1 320	718 590 741 to 0 770
694 595 087 to 5 300	702 660 151 to 0 540	709 649 804 to 9 820	718 714 210 to 4 370
694 698 551 to 8 650	702 723 429 to 3 450	709 733 281 to 3 580	718 795 881 to 6 000
694 745 458 to 5 600	703 004 401 to 4 820	710 046 813 to 6 840	718 961 721 to 1 780
695 105 313 to 5 350	703 083 819 to 4 020	710 358 093 to 8 166	718 982 001 to 2 300
695 142 809 to 3 050	703 432 131 to 2 230	710 358 257 to 8 270	719 869 731 to 9 760
695 144 666 to 4 700	703 626 061 to 6 090	711 021 501 to 1 510	720 227 871 to 7 930
695 272 601 to 2 750	703 863 121 to 3 240	711 049 411 to 9 560	720 227 949 to 7 960
695 277 576 to 7 650	703 863 477 to 3 540	711 408 045 to 8 090	720 368 543 to 8 570
695 530 761 to 0 800	703 867 801 to 7 980	712 003 381 to 3 650	720 392 151 to 2 570
696 487 701 to 7 800	704 030 628 to 0 640	712 104 220 to 4 230	720 556 491 to 6 640
696 784 101 to 4 550	704 154 024 to 4 120	712 327 861 to 7 890	720 558 621 to 8 650
696 870 601 to 0 650	704 227 561 to 7 829	712 327 952 to 7 980	720 575 361 to 5 570
697 047 501 to 7 600	704 227 831 to 8 069	712 647 061 to 7 090	720 590 152 to 0 179
697 052 101 to 2 350	704 228 071 to 8 100	713 284 171 to 4 260	721 638 331 to 9 170
697 217 251 to 7 400	704 420 344 to 0 490	713 292 871 to 2 990	721 815 391 to 5 420
697 249 952 to 50 050	704 568 751 to 8 990	714 035 101 to 5 160	721 969 713 to 9 740
697 414 886 to 4 900	704 965 301 to 5 770	714 155 011 to 5 400	722 072 137 to 2 160
697 469 606 to 9 700	705 116 780 to 6 790	714 328 231 to 8 440	722 378 265 to 8 280
697 850 401 to 0 750	705 280 801 to 0 980	714 442 952 to 2 980	722 413 990 to 4 004
698 098 446 to 8 550	705 475 651 to 6 040	714 562 843 to 2 860	722 764 948 to 4 980
698 300 251 to 0 300	705 566 127 to 6 280	714 590 391 to 0 430	722 825 840 to 5 889
698 504 383 to 4 650	705 740 581 to 0 730	714 609 811 to 9 930	723 153 841 to 3 850
698 533 927 to 4 200	705 782 796 to 2 820	714 609 961 to 9 990	723 237 616 to 7 630
698 562 268 to 2 400	705 822 271 to 2 480	714 807 181 to 7 240	723 331 081 to 1 110
699 090 686 to 0 750	706 180 148 to 0 290	714 871 321 to 1 500	723 496 443 to 6 470
699 752 699 to 2 850	706 184 041 to 4 220	714 928 529 to 8 590	723 967 291 to 7 320
700 068 473 to 8 500	706 357 861 to 8 190	715 128 183 to 8 330	724 655 196 to 5 340
700 161 501 to 1 650	706 382 419 to 2 430	715 144 171 to 4 470	724 711 441 to 1 500
700 202 522 to 2 700	706 628 735 to 8 820	715 197 211 to 7 570	724 711 538 to 1 560
700 290 275 to 0 300	706 638 211 to 8 420	715 595 910 to 6 180	724 793 221 to 3 250
700 465 730 to 5 750	706 817 959 to 8 000	715 941 781 to 1 810	724 908 109 to 8 120
700 561 444 to 1 550	707 034 391 to 4 450	715 962 421 to 2 480	724 937 461 to 7 670
701 423 101 to 3 150	707 292 636 to 2 660	716 477 396 to 7 430	725 163 118 to 3 151
701 625 469 to 5 550	707 441 401 to 1 687	716 556 635 to 6 660	725 202 735 to 2 750
701 643 829 to 3 850	707 441 836 to 1 940	717 191 648 to 1 690	725 398 591 to 8 800

725 464 591 to 4 920	732 541 605 to 1 620	740 889 081 to 9 090	752 139 516 to 9 570
725 475 321 to 5 330	732 572 221 to 2 490	741 010 421 to 0 530	752 182 892 to 2 950
725 711 057 to 1 070	732 586 479 to 6 710	741 113 041 to 3 370	752 206 861 to 7 100
725 738 581 to 8 730	732 994 037 to 4 080	741 373 891 to 4 340	752 295 241 to 5 600
725 981 311 to 1 430	733 163 449 to 3 460	741 452 369 to 2 490	752 731 351 to 1 410
725 987 835 to 7 880	733 297 171 to 7 290	741 492 991 to 3 140	752 767 441 to 7 470
726 060 811 to 0 900	733 446 631 to 7 110	741 553 460 to 3 470	753 008 941 to 9 030
726 391 970 to 2 520	733 474 665 to 4 770	741 764 431 to 4 520	753 194 311 to 4 370
726 484 771 to 4 800	733 704 482 to 4 570	742 178 834 to 8 880	753 620 378 to 0 400
726 493 351 to 5 300	733 751 041 to 1 130	742 325 500 to 5 520	754 013 917 to 3 940
726 504 031 to 4 063	734 009 101 to 9 130	742 325 668 to 5 700	754 161 061 to 1 120
726 504 070 to 4 090	734 290 759 to 0 770	742 408 771 to 8 830	754 358 445 to 8 610
726 504 331 to 4 390	734 389 273 to 9 290	742 512 120 to 2 150	754 410 451 to 0 660
726 563 701 to 4 060	734 440 031 to 0 111	742 684 849 to 4 890	754 438 393 to 8 410
726 599 371 to 9 460	734 797 201 to 7 320	742 839 553 to 9 630	754 493 109 to 3 130
726 626 356 to 6 370	734 939 611 to 9 640	742 913 668 to 3 700	754 664 182 to 4 220
727 182 271 to 2 510	734 950 111 to 0 170	742 917 287 to 7 296	754 816 377 to 6 470
727 416 181 to 6 240	735 120 331 to 0 840	742 921 891 to 1 980	755 487 421 to 7 600
727 481 431 to 1 460	735 283 008 to 3 020	742 983 631 to 3 810	755 592 901 to 3 140
727 749 241 to 9 780	735 293 131 to 3 220	743 020 021 to 0 170	755 790 020 to 0 030
728 382 331 to 2 480	735 635 010 to 5 040	743 206 491 to 6 500	755 791 730 to 1 800
728 702 338 to 2 400	735 783 961 to 3 990	743 235 992 to 6 050	755 926 951 to 7 070
728 915 371 to 5 850	735 803 401 to 3 430	743 940 631 to 0 900	755 934 332 to 4 510
728 953 141 to 3 410	736 005 420 to 5 440	743 978 011 to 8 070	755 957 701 to 8 000
728 954 280 to 4 310	736 366 021 to 6 110	744 234 751 to 4 780	755 962 981 to 3 280
729 169 081 to 9 140	736 624 456 to 4 500	744 499 591 to 9 680	756 035 371 to 5 490
729 363 841 to 3 870	736 670 851 to 1 060	744 626 901 to 6 910	756 301 257 to 1 290
729 682 891 to 3 190	736 767 061 to 7 090	745 388 794 to 8 910	756 371 565 to 1 580
729 838 940 to 9 070	736 767 093 to 7 120	746 446 806 to 6 820	756 876 031 to 6 120
729 839 101 to 9 130	736 982 191 to 2 370	746 818 351 to 8 410	756 876 151 to 6 240
730 077 683 to 7 840	736 982 551 to 2 730	747 245 266 to 5 280	756 970 129 to 0 140
730 109 847 to 9 880	737 110 141 to 0 170	747 364 813 to 4 830	757 059 613 to 9 630
730 373 761 to 3 850	737 185 501 to 5 710	747 501 434 to 1 450	757 078 540 to 8 560
730 501 951 to 2 130	737 317 321 to 7 350	747 739 891 to 0 070	757 086 209 to 6 240
730 519 379 to 9 470	737 517 781 to 7 840	748 148 649 to 8 760	757 240 591 to 0 650
730 569 278 to 9 360	737 628 181 to 8 210	748 259 960 to 9 970	757 277 371 to 7 700
730 711 711 to 1 740	737 634 258 to 4 270	748 565 162 to 5 280	757 291 591 to 2 730
730 722 991 to 3 230	738 361 971 to 1 980	748 874 988 to 5 030	757 964 251 to 4 280
730 845 970 to 5 990	738 447 601 to 7 660	749 137 381 to 7 410	758 067 001 to 7 090
730 888 291 to 8 320	738 648 355 to 8 450	749 190 192 to 0 210	758 105 221 to 5 250
730 927 591 to 7 680	738 849 811 to 9 900	749 685 421 to 5 450	758 324 941 to 5 000
731 307 914 to 7 930	738 892 270 to 2 290	749 846 791 to 6 850	758 593 628 to 3 650
731 402 431 to 2 460	738 997 259 to 7 380	749 993 131 to 3 580	758 709 038 to 9 060
731 407 232 to 7 320	739 161 451 to 1 540	750 071 587 to 1 610	758 744 101 to 4 160
731 588 301 to 8 340	739 219 381 to 9 440	750 408 167 to 8 183	758 850 883 to 0 900
731 767 273 to 7 320	739 740 151 to 0 180	750 438 421 to 8 501	758 860 951 to 1 550
731 781 061 to 1 120	739 793 491 to 3 520	750 743 911 to 4 030	759 152 851 to 2 880
731 837 821 to 7 910	739 793 527 to 3 550	750 779 118 to 9 400	759 740 941 to 1 090
731 841 377 to 1 450	739 942 621 to 2 650	750 910 981 to 1 010	760 004 596 to 4 610
732 018 481 to 8 600	739 999 231 to 9 320	750 960 841 to 0 900	760 118 191 to 8 250
732 067 972 to 8 370	740 011 517 to 1 530	751 296 211 to 6 240	760 155 001 to 5 090
732 188 649 to 8 670	740 030 701 to 0 970	751 539 121 to 9 180	760 378 002 to 8 020
732 193 460 to 3 470	740 261 740 to 1 820	751 541 311 to 1 790	760 692 722 to 2 749
732 201 241 to 1 390	740 265 811 to 6 290	751 757 641 to 7 700	761 055 460 to 5 480
732 220 431 to 0 440	740 299 111 to 9 170	751 936 951 to 7 010	761 169 781 to 9 810
732 355 201 to 5 380	740 299 231 to 9 260	751 951 861 to 1 890	761 504 941 to 5 120
732 472 320 to 2 560	740 329 266 to 9 320	751 999 021 to 9 110	761 516 836 to 6 910

761 613 588	to	3 600	765 042 517	to	2 540	769 778 491	to	8 730	774 431 821	to	2 450
761 688 631	to	8 690	765 194 728	to	4 970	769 827 331	to	7 450	774 510 451	to	0 780
761 805 199	to	5 240	765 387 365	to	7 450	770 216 071	to	6 100	774 652 981	to	3 010
761 826 106	to	6 120	765 541 801	to	2 100	770 723 281	to	3 400	774 778 981	to	9 040
761 881 171	to	1 560	765 638 461	to	8 970	770 915 150	to	5 490	774 867 481	to	7 510
762 304 144	to	4 170	765 647 101	to	7 190	771 455 551	to	5 610	774 867 515	to	7 540
762 324 931	to	4 960	765 813 781	to	4 029	771 609 661	to	9 690	774 934 275	to	4 290
762 439 261	to	9 290	765 879 314	to	9 390	772 057 224	to	7 440	774 961 261	to	1 290
762 524 158	to	4 220	765 954 001	to	4 030	772 162 660	to	3 070	775 106 223	to	6 235
762 584 872	to	4 970	766 120 286	to	0 320	772 718 615	to	8 640	775 106 237	to	6 248
762 593 431	to	3 460	766 125 716	to	5 750	772 970 890	to	0 940	775 331 515	to	1 550
763 155 160	to	5 180	766 158 824	to	8 840	773 009 419	to	9 430	775 444 210	to	4 230
763 178 631	to	8 660	766 388 433	to	8 460	773 112 031	to	2 060	775 579 301	to	9 320
763 506 001	to	6 060	766 509 421	to	9 660	773 125 387	to	5 410	775 622 683	to	2 760
763 522 141	to	2 470	766 572 901	to	3 020	773 179 320	to	9 410	776 144 621	to	4 670
763 717 694	to	7 800	766 748 500	to	8 521	773 202 989	to	3 140	776 154 001	to	4 060
763 826 461	to	6 520	767 024 341	to	4 370	773 208 991	to	9 290	776 561 041	to	1 100
763 900 460	to	0 471	767 326 471	to	6 590	773 231 311	to	1 340	777 561 631	to	2 080
763 900 479	to	0 530	767 332 561	to	2 950	773 348 739	to	8 940	776 657 371	to	7 490
763 917 271	to	7 750	768 009 841	to	9 960	773 575 891	to	5 950	776 817 421	to	7 450
764 125 801	to	5 860	768 011 489	to	1 520	773 858 011	to	8 100	777 621 721	to	1 750
764 284 525	to	4 560	768 177 980	to	7 990	773 892 721	to	7 190	777 810 309	to	0 330
764 526 241	to	6 330	768 391 081	to	1 170	773 958 061	to	8 660	778 049 651	to	9 670
764 601 421	to	1 600	768 661 569	to	1 650	774 107 161	to	7 190	778 106 225	to	6 310
764 650 231	to	0 470	769 000 051	to	0 080	774 177 226	to	7 270	778 286 911	to	6 940
764 984 371	to	4 850	769 159 081	to	9 178	774 279 481	to	9 810	780 644 131	to	4 220
765 003 667	to	3 680	769 737 496	to	7 510	774 408 399	to	8 420			

— Postal Inspection Service, 5-16-02

Counterfeit Canadian Money Order Forms

Do Not Cash

To be posted and used by retail window employees. As directed, destroy previous notices. All interim notices should be destroyed when the numbers listed appear in the *Postal Bulletin*.

671,819,086	686,794,382
676,612,640	686,794,426
677,891,039	686,794,427
678,282,493	686,794,431
678,916,031	687,262,502
679,552,215	687,262,503
679,694,334	687,262,525
679,751,983	687,262,526
679,800,207	687,287,578
681,130,536	687,287,581
681,844,376	687,287,582
683,594,542	694,063,898
684,683,610	694,063,899
686,619,878	694,063,980
686,619,886	701,321,725
686,619,887	

— Postal Inspection Service, 5-16-02

800 Number Available to Verify Canadian Money Orders

The Canada Post Corporation is now providing an 800 number that cashing agents can call to verify the validity of Canadian Postal Money Orders. The number is 800-563-0444.

This 800 number is printed on the back of the Canadian Postal Money Orders.

— Postal Inspection Service, 5-16-02

International Mail

ICM UPDATES

International Customized Mail

We have combined ICM updates into one *Postal Bulletin* article to save space and paper. Five ICM updates are included in this article.

On April 12, 2002, the Postal Service entered into an International Customized Mail (ICM) Service Agreement with a qualifying mailer. In accordance with *International Mail Manual* (IMM) 297.4, the Postal Service now makes public the following information concerning the Agreement:

- a. **Term:** April 30, 2002, through April 30, 2003.
- b. **Type of mail:** Global Express Mail™ Service (EMS). Every item must conform to the mailing requirements set forth in the IMM for Qualifying Mail.
- c. **Destination country:** Japan.
- d. **Service provided by the Postal Service:** The Postal Service has agreed to:
 1. Furnish Mailer, or Mailing Agent(s), with the postal equipment and postal supplies required for the use of Qualifying Mail.
 2. Provide Mailer with the preparation requirements and training necessary to prepare mail shipments in conformity with the requirement for Qualifying Mail.
 3. Perform on-demand and scheduled pickup service at the request of the Mailer at the published rate for this service in accordance with IMM 220.
- e. **Minimum volume commitment:** The Mailer has agreed to tender at least 50,000 pieces of Qualifying Mail on an annualized basis for the duration of the Agreement.
- f. **Worksharing:** The Mailer has agreed to pay postage for all Qualifying Mail by use of an Express Mail® Corporate Account.
- g. **Rates:** The Mailer has agreed to pay postage for Global EMS to Japan at a discount of fourteen (14) percent off the published rate.

On April 24, 2002, the Postal Service entered into an International Customized Mail (ICM) Service Agreement with a qualifying mailer. In accordance with *International Mail Manual* (IMM) 294, the Postal Service now makes public the following information concerning the Agreement:

- a. **Term:** April 26, 2002, through April 30, 2005.
- b. **Type of mail:** International Priority Airmail™ Service (IPA), International Surface Air Lift™ Service (ISAL), and Global Bulk Economy Service (GBE). Every item must conform to the mailing requirements set forth in the IMM for Qualifying Mail.
- c. **Destination countries:** Worldwide.
- d. **Service provided by the Postal Service:** The Postal Service has agreed to:
 1. Furnish the Mailer with the postal equipment and postal supplies required for the use of Qualifying Mail.
 2. Provide the Mailer with the preparation requirements for Qualifying Mail and any training necessary to prepare ICM Mail in conformity with the requirements for Qualifying Mail.
 3. Arrange with carriers to transport Qualifying Mail to international destinations for delivery by the appropriate authority.

- e. Minimum volume commitment:** The Mailer has agreed to tender to the Postal Service mail intended for delivery outside the United States that generates at least \$25 million in actual postage in each year beginning on the effective date of this Agreement and ending on each anniversary of this date for the duration of the Agreement.
- f. Worksharing:** The Mailer has agreed to:
1. Tender at least ninety-nine (99) percent of IPA Qualifying Mail in drop shipments to the appropriate locations specified in IMM 292.153.
 2. Tender at least ninety-nine (99) percent of ISAL Qualifying Mail in drop shipments to the appropriate locations specified in IMM 293.32.
 3. Tender no more than one (1) percent of IPA and ISAL Qualifying Mail to other postal facilities at the national rate or full service rate as appropriate.
 4. Drop-ship GBE Qualifying Mail at the New Jersey International and Bulk Mail Center.
 5. Provide the Postal Service with notification of intent to drop ship Qualifying Mail at a specific International Service Center (ISC) 2 weeks before the initial shipment to that ISC.
 6. Provide the Postal Service with notification of new dedicated permit numbers 2 weeks in advance of using the new dedicated permit numbers.
 7. Provide the Postal Service with projections of mailings to include the intended date of mailing, weight, and volume of the mailings.

On April 23, 2002, the Postal Service entered into an International Customized Mail (ICM) Service Agreement with a qualifying mailer. In accordance with *International Mail Manual* (IMM) 297.4, the Postal Service now makes public the following information concerning the Agreement:

- a. Term:** May 7, 2002, through May 6, 2003.
- b. Type of mail:** Global Express Mail™ Service (EMS). Every item must conform to the mailing requirements set forth in the IMM for EMS.
- c. Destination countries:** Worldwide.
- d. Service provided by the Postal Service:** The Postal Service has agreed to transport EMS to international destinations for delivery by the appropriate authorities.
- e. Minimum volume commitment:** The Mailer has agreed to meet an annualized minimum of 600 pieces of EMS.

8. Pay postage to the Postal Service for GBE using an exclusive permit imprint number.
 9. Pay postage to the Postal Service for ICM Qualifying Mail using dedicated permit imprints.
- g. Rates:** The Mailer has agreed to pay postage for
1. GBE at rates discounted sixteen (16) percent off the base rates contained in Exhibit 1.
 2. Qualifying Mail at discounted rates as detailed in Exhibit 2, based on a commitment of at least \$25 million in actual postage on an annualized basis.

Exhibit 1
Global Bulk Economy Base Rates

Rate Group	Per-PTHiece + Per-Lb.
1 (Western Europe)	\$0.20 + \$2.04
2 (Japan, Australia, New Zealand)	\$0.20 + \$2.16
3 (Rest of World)	\$0.12 + \$3.36

Exhibit 2

Total Annual IPA, ISAL, and GBE Revenue (After Discount Is Taken) (\$)	Percentage Discount (%)
2,000,000 – 4,999,999	5.00
5,000,000 – 5,999,999	10.00
6,000,000 – 6,999,999	11.00
7,000,000 – 7,999,999	12.00
8,000,000 – 8,999,999	13.00
9,000,000 – 9,999,999	14.00
10,000,000 – 14,999,999	15.25
15,000,000 – 19,999,999	15.50
20,000,000 – 24,999,999	15.75
25,000,000 and over	16.00

- f. Worksharing:** The Mailer has agreed to:
1. Comply with the terms and conditions for mailing EMS as set forth in the IMM.
 2. Pay postage for EMS by means of a dedicated Express Mail® Corporate Account (EMCA) in accordance with the EMCA requirements set forth in the *Domestic Mail Manual* (DMM).
- g. Rates:** The Mailer has agreed to pay postage at a rate discounted at eight (8) percent off of nondiscounted published rates in effect on the date of mailing in accordance with Exhibit 1.

Exhibit 1

Annualized Volume (Piece) or Annualized Postage (\$)	Discount Applied (%)
600 – 999 or 12,000 – 19,999	8
1,000 – 2,999 or 20,000 – 59,999	10
3,000 – or more or 60,000 – or more	12

On April 16, 2002, the Postal Service entered into an International Customized Mail (ICM) Service Agreement with a qualifying mailer. In accordance with *International Mail Manual* (IMM) 297.4, the Postal Service now makes public the following information concerning the Agreement:

- a. **Term:** April 30, 2002, through April 29, 2005.
- b. **Type of mail:** Global Express Mail™ Service (EMS). Every item must conform to the mailing requirements set forth in the IMM for EMS.
- c. **Destination countries:** Worldwide.
- d. **Service provided by the Postal Service:** The Postal Service has agreed to transport EMS to international destinations for delivery by the appropriate authorities.
- e. **Minimum volume commitment:** The Mailer has agreed to meet an annualized minimum of 610 pieces of EMS.

On April 12, 2002, the Postal Service entered into an International Customized Mail (ICM) Service Agreement with a qualifying mailer. In accordance with *International Mail Manual* (IMM) 297.4, the Postal Service now makes public the following information concerning the Agreement:

- a. **Term:** April 22, 2002, through April 21, 2003.
- b. **Type of mail:** Global Express Mail™ Service (EMS) and Airmail™ Parcel Post. Every item must conform to the mailing requirements set forth in the IMM for Qualifying Mail.
- c. **Destination countries:** Worldwide.
- d. **Services provided by the Postal Service:** The Postal Service has agreed to:
 1. Furnish Mailer, or Mailing Agent(s), with the postal equipment and postal supplies required for the use of Qualifying Mail.
 2. Provide Mailer, or its agents, with training necessary to prepare mail shipments in conformity with the requirements for Qualifying Mail.
 3. Provide the Mailer with technical assistance necessary to prepare the necessary information linkages, electronic data files, and data exchanges.
 4. Perform on-demand and scheduled pickup service at the request of the Mailer.
 5. Arrange with carriers to transport Qualifying Mail to international destinations for delivery by the appropriate authority.

- f. **Worksharing:** The Mailer has agreed to:
 1. Comply with the terms and conditions for mailing EMS as set forth in the IMM.
 2. Pay postage for EMS by means of a dedicated Express Mail® Corporate Account (EMCA) in accordance with the EMCA requirements set forth in the *Domestic Mail Manual* (DMM).
- g. **Rates:** The Mailer has agreed to pay postage at a rate discounted at eight (8) percent off of nondiscounted published rates in effect on the date of mailing in accordance with Exhibit 1.

Exhibit 1

Annualized Volume (Piece) or Annualized Postage (\$)	Discount Applied (%)
600 – 999 or 12,000 – 19,999	8
1,000 – 2,999 or 20,000 – 59,999	10
3,000 – or more or 60,000 or more	12

6. Return Global Express Mail Service items refused by an addressee and undeliverable items to the Mailer via Express Mail® at no charge provided that the return rate is no more than four (4) percent of the total volume.
 7. Return Airmail Parcel Post items refused by an addressee and undeliverable items to the Mailer according to the provisions of IMM 771.
 8. Return Global Express Mail Service (EMS) items and Airmail Parcel Post items receiving Customs Pre-Payment in Great Britain, whether refused by an addressee or undeliverable, to the Mailer at the same fees as for Merchandise Return Service.
 9. Provide the Mailer with tracking reports, if applicable to the service, and delivery performance reports on a regular basis.
 10. Provide a customized binding Proposal detailing the number of hours required to complete a harmonization process at the Mailer's request.
 11. Apply a Postal Service shipping label and Customs documentation to each package.
 12. Send an electronic data file to Great Britain that will allow the Customs officials to review the contents of each shipment before the packages arrive.
- e. **Minimum volume commitment:** The Mailer has agreed to tender at least 5,000 pieces of Qualifying Mail on an annualized basis for the duration of the Agreement or to pay at least \$100,000 in postage for Qualifying Mail on an annualized basis for the duration of the Agreement.

f. Worksharing: The Mailer has agreed to:

1. Establish the necessary linkages with the Postal Service so that the Mailer and the Postal Service can exchange data transmissions concerning the Mailer's packages and so that the Postal Service can extract information by scanning the Mailer-provided barcode on each package.
2. Exchange electronic information with the Postal Service according to the specifications and instructions the Postal Service provides.
3. Pay postage, either directly or through a mailing agent, by use of a permit imprint subject to the conditions stated in DMM P040 (with the exception that DMM P040.1.1 shall not apply) and IMM 152.3.
4. Provide the Postal Service with notification of new permit numbers to be used for Qualifying Mail 1 week in advance of the use of the new permit numbers.
5. Provide the Postal Service with a schedule of mailings, including the intended date of tender, weight, volume, and location where the mail will originate.
6. Present the mailings to the Postal Service at the Detached Mail Unit at the Mailer's plant.
7. Pay for any requested harmonization at a rate of \$250 per hour.

g. Rates: The Mailer has agreed to pay postage:

1. For Global Express Mail Service (EMS), Airmail Parcel Post, Return Service for unopened items, and Merchandise Return Service according to the following charts.

**Global Express Mail (EMS) Postal Service
Labeling, Customs Pre-Advice, Landed Cost,
and Customs Pre-Payment**

Weight Not Over (lbs.)	Great Britain (\$)
0.5	14.13
1	16.96
2	19.33
3	21.71
4	23.49
5	25.28
6	27.06
7	28.84
8	30.62
9	32.41
10	34.19
11	35.97

Weight Not Over (lbs.)	Great Britain (\$)
12	37.75
13	39.54
14	41.32
15	43.10
16	44.88
17	46.67
18	48.45
19	50.23
20	52.01
21	53.80
22	55.58
23	57.36
24	59.14
25	60.93
26	62.71
27	64.49
28	66.28
29	68.06
30	69.84
31	71.62
32	73.41
33	75.19
34	76.97
35	78.75
36	80.54
37	82.32
38	84.10
39	85.88
40	87.67
41	89.45
42	91.23
43	93.01
44	94.80
45	96.58
46	98.36
47	100.14
48	101.93
49	103.71
50	105.49
51	107.27
52	109.06
53	110.84
54	112.62
55	114.41
56	116.19
57	117.97
58	119.75
59	121.54
60	123.32
61	125.10
62	126.88
63	128.67
64	130.45
65	132.23
66	134.01

Airmail Parcel Post Postal Service Labeling, Customs Pre-Advice, Landed Cost, and Customs Pre-Payment

Weight Not Over (lbs.)	Great Britain (\$)
1	11.47
2	13.77
3	16.08
4	18.38
5	20.69
6	22.42
7	24.15
8	25.87
9	27.60
10	29.33
11	31.06
12	32.79
13	34.52
14	36.25
15	37.97
16	39.70
17	41.43
18	43.16
19	44.89
20	46.62
21	48.35
22	50.07
23	51.80
24	53.53
25	55.26
26	56.99
27	58.72
28	60.45
29	62.17
30	63.90
31	65.63
32	67.36
33	69.09

Weight Not Over (lbs.)	Great Britain (\$)
34	70.82
35	72.55
36	74.28
37	76.00
38	77.73
39	79.46
40	81.19
41	82.92
42	84.65
43	86.38
44	88.10
45	89.83
46	91.56
47	93.29
48	95.02
49	96.75
50	98.48
51	100.20
52	101.93
53	103.66
54	105.39
55	107.12
56	108.85
57	110.58
58	112.30
59	114.03
60	115.76
61	117.49
62	119.22
63	120.95
64	122.68
65	124.40
66	126.13

Global Express Mail (EMS) With Postal Service Labeling

Weight Not Over (lbs.)	Group 1 Canada (\$)	Group 2 Mexico (\$)	Group 3 Great Britain (\$)	Group 4 Japan (4)	Group 5 China (\$)	Group 6 (\$)	Group 7 (\$)	Group 8 Hong Kong (\$)	Group 8 (\$)	Group 9 (\$)	Group 10 (\$)	Group 11 (\$)	Group 12 (\$)
0.5	13.71	14.69	17.25	14.89	16.46	14.89	19.61	12.90	14.89	16.46	19.42	23.94	19.02
1	14.30	17.25	20.99	18.04	19.42	16.58	21.98	15.24	17.64	18.83	21.38	26.11	20.99
2	14.89	20.16	24.14	21.19	22.01	18.55	24.34	17.59	20.40	21.98	23.75	29.46	23.55
3	15.87	23.24	27.29	24.34	25.52	21.15	26.70	20.27	23.55	25.13	27.09	33.39	26.70
4	16.66	25.99	29.65	27.49	28.98	23.67	29.06	22.95	26.70	29.06	30.24	36.74	29.85
5	17.64	28.43	32.02	30.44	32.37	26.58	31.43	25.63	29.85	33.00	33.59	40.68	33.00
6	19.42	30.17	34.38	33.04	35.72	29.02	33.95	28.45	33.16	36.66	36.94	44.42	36.15
7	21.19	31.90	36.74	35.64	39.06	31.46	36.47	31.26	36.47	40.32	40.28	48.16	39.30
8	22.96	33.63	39.10	38.24	42.41	33.91	38.99	34.08	39.77	43.99	43.63	51.90	42.45
9	24.73	35.36	41.47	40.84	45.76	36.35	41.51	36.89	43.08	47.65	46.98	55.64	45.60
10	26.50	37.10	43.83	43.43	49.10	38.79	44.03	39.71	46.39	51.31	50.33	59.38	48.75
11	28.28	38.83	46.19	46.03	52.45	41.23	46.55	42.52	49.70	54.97	53.67	63.12	51.90
12	30.05	40.56	48.55	48.63	55.80	43.67	49.07	45.34	53.00	58.63	57.02	66.86	55.05
13	31.82	42.29	50.92	51.23	59.15	46.11	51.59	48.15	56.31	62.30	60.37	70.60	58.20
14	33.59	44.03	53.28	53.83	62.49	48.55	54.11	50.97	59.62	65.96	63.71	74.34	61.35
15	35.36	45.76	55.64	56.43	65.84	50.99	56.63	53.78	62.93	69.62	67.06	78.08	64.50
16	37.13	47.49	58.00	59.03	69.19	53.44	59.15	56.60	66.23	73.28	70.41	81.83	67.65
17	38.91	49.22	60.37	61.63	72.53	55.88	61.67	59.41	69.54	76.94	73.75	85.57	70.80
18	40.68	50.96	62.73	64.22	75.88	58.32	64.19	62.23	72.85	80.60	77.10	89.31	73.95
19	42.45	52.69	65.09	66.82	79.23	60.76	66.71	65.04	76.16	84.27	80.45	93.05	77.10
20	44.22	54.42	67.45	69.42	82.57	63.20	69.23	67.86	79.46	87.93	83.79	96.79	80.25
21	45.99	56.15	69.82	72.02	85.92	65.64	71.75	70.67	82.77	91.59	87.14	100.53	83.40
22	47.77	57.89	72.18	74.62	89.27	68.08	74.27	73.49	86.08	95.25	90.49	104.27	86.55
23	49.54	59.62	74.54	77.22	92.61	70.52	76.79	76.31	89.39	98.91	93.83	108.01	89.70
24	51.31	61.35	76.90	79.82	95.96	72.97	79.31	79.12	92.69	102.58	97.18	111.75	92.85
25	53.08	63.08	79.27	82.42	99.31	75.41	81.83	81.94	96.00	106.24	100.53	115.49	96.00
26	54.85	64.82	81.63	85.01	102.65	77.85	84.35	84.75	99.31	109.90	103.88	119.23	99.15
27	56.63	66.55	83.99	87.61	106.00	80.29	86.87	87.57	102.62	113.56	107.22	122.97	102.30
28	58.40	68.28	86.35	90.21	109.35	82.73	89.39	90.38	105.92	117.22	110.57	126.71	105.45
29	60.17	70.01	88.72	92.81	112.70	85.17	91.91	93.20	109.23	120.89	113.92	130.45	108.60
30	61.94	71.75	91.08	95.41	116.04	87.61	94.43	96.01	112.54	124.55	117.26	134.19	111.75
31	63.71	73.48	93.44	98.01	119.39	90.05	96.95	98.83	115.85	128.21	120.61	137.93	114.90
32	65.48	75.21	95.80	100.61	122.74	92.50	99.47	101.64	119.15	131.87	123.96	141.68	118.05
33	67.26	76.94	98.17	103.21	126.08	94.94	101.99	104.46	122.46	135.53	127.30	145.42	121.20

Airmail Parcel Post With Postal Service Labeling

Weight Not Over (lbs.)	Group 1 Canada (\$)	Group 2 Mexico (\$)	Group 3 Great Britain (\$)	Group 4 Japan (4)	Group 5 China (\$)	Group 6 (\$)	Group 7 (\$)	Group 8 (\$)	Group 9 (\$)	Group 10 (\$)	Group 11 (\$)	Group 12 (\$)	Group 13 (\$)
1	12.26	12.05	14.49	5.99	13.88	12.86	14.89	11.65	13.27	14.49	16.11	12.86	15.30
2	12.26	14.08	17.74	10.29	17.53	14.08	16.92	14.49	16.72	16.52	19.36	14.08	16.92
3	13.07	15.91	20.98	14.58	21.39	15.71	19.16	17.74	20.37	18.95	22.61	15.50	19.36
4	14.08	17.94	24.23	18.88	25.65	17.94	21.39	21.18	23.21	20.98	25.85	17.13	21.79
5	15.10	20.17	27.48	-	29.91	19.97	23.62	24.84	28.08	23.01	29.10	18.75	24.23
6	15.99	21.79	29.91	-	33.36	22.32	26.06	28.00	31.13	25.45	31.94	20.78	26.87
7	16.88	23.42	32.35	-	36.81	24.68	28.49	31.17	34.29	27.88	34.78	22.81	29.51
8	17.78	25.04	34.78	-	40.26	27.03	30.93	34.34	37.46	30.32	37.62	24.84	32.14
9	18.67	26.66	37.22	-	43.71	29.38	33.36	37.50	40.63	32.75	40.46	26.87	34.78
10	19.56	28.29	39.65	-	47.16	31.74	35.80	40.67	43.79	35.19	43.31	28.90	37.42
11	20.45	29.91	42.09	-	50.61	34.09	38.23	43.83	46.96	37.62	46.15	30.93	40.06
12	21.35	31.53	44.52	-	54.06	36.45	40.67	47.00	50.12	40.06	48.99	32.96	42.70
13	22.24	33.16	46.96	-	57.51	38.80	43.10	50.16	53.29	42.49	51.83	34.98	45.33
14	23.13	34.78	49.39	-	60.96	41.15	45.54	53.33	56.46	44.93	54.67	37.01	47.97
15	24.03	36.41	51.83	-	64.41	43.51	47.97	56.50	59.62	47.36	57.51	39.04	50.61
16	24.92	38.03	54.26	-	67.86	45.86	50.41	59.66	62.79	49.80	60.35	41.07	53.25
17	25.81	39.65	56.70	-	71.31	48.22	52.84	62.83	65.95	52.23	63.19	43.10	55.89
18	26.70	41.28	59.13	-	74.76	50.57	55.28	65.99	69.12	54.67	66.03	45.13	58.53
19	27.60	42.90	61.57	-	78.21	52.92	57.71	69.16	72.28	57.10	68.88	47.16	61.16
20	28.49	44.52	64.00	-	81.66	55.28	60.15	72.33	75.45	59.54	71.72	49.19	63.80
21	29.38	46.15	66.44	-	85.11	57.63	62.58	75.49	78.62	61.98	74.56	51.22	66.44
22	30.28	47.77	68.88	-	88.56	59.99	65.02	78.66	81.78	64.41	77.40	53.25	69.08
23	31.17	49.39	71.31	-	92.01	62.34	67.45	81.82	84.95	66.85	80.24	55.28	71.72
24	32.06	51.02	73.75	-	95.46	64.69	69.89	84.99	88.11	69.28	83.08	57.31	74.35
25	32.96	52.64	76.18	-	98.91	67.05	72.33	88.15	91.28	71.72	85.92	59.34	76.99
26	33.85	54.26	78.62	-	102.36	69.40	74.76	91.32	94.45	74.15	88.76	61.37	79.63
27	34.74	55.89	81.05	-	105.81	71.76	77.20	94.49	97.61	76.59	91.60	63.40	82.27
28	35.63	57.51	83.49	-	109.26	74.11	79.63	97.65	100.78	79.02	94.45	65.43	84.91
29	36.53	59.13	85.92	-	112.71	76.47	82.07	100.82	103.94	81.46	97.29	67.45	87.55
30	37.42	60.76	88.36	-	116.16	78.82	84.50	103.98	107.11	83.89	100.13	69.48	90.18
31	38.31	62.38	90.79	-	119.61	81.17	86.94	107.15	110.27	86.33	102.97	71.51	92.82
32	39.21	64.00	93.23	-	123.06	83.53	89.37	110.32	113.44	88.76	105.81	73.54	95.46
33	40.10	65.63	95.66	-	126.51	85.88	91.81	113.48	116.61	91.20	108.65	75.57	98.10

Fees for Return Service and Merchandise Return Service

Weight Not Over (lbs.)	Great Britain (\$)
1	6.93
2	7.40
3	8.79
4	9.26
5	10.66
6	11.12
7	12.52
8	12.99
9	14.38
10	14.85
11	15.32
12	16.72
13	17.18
14	18.58
15	19.05
16	20.44
17	20.91
18	22.31
19	22.77
20	24.17
21	24.64
22	25.10
23	26.50
24	26.97
25	28.37
26	28.83
27	30.32
28	30.70
29	32.09
30	32.56
31	33.96
32	34.42
33	34.89

Weight Not Over (lbs.)	Great Britain (\$)
34	36.29
35	36.75
36	38.15
37	38.62
38	40.02
39	40.48
40	41.88
41	42.35
42	43.74
43	44.21
44	44.68
45	46.07
46	46.54
47	47.94
48	48.40
49	49.80
50	50.27
51	51.67
52	52.13
53	53.53
54	54.00
55	54.46
56	55.86
57	56.33
58	57.72
59	58.19
60	59.59
61	60.55
62	61.45
63	61.92
64	63.32
65	63.78
66	64.25

— *International Business, 5-16-02*

Philately

STAMP ANNOUNCEMENT 02-10

Star Definitive Stamp



Copyright USPS 2002

The Postal Service will issue a 3-cent *Star* definitive stamp in a pressure-sensitive adhesive (PSA) pane of 50 (Item 100300) and a water-activated gum (WAG) coil of 10,000 (Item 781300) on June 7, 2002, in Washington, DC. The stamp was illustrated by Phil Jordan of Falls Church, Virginia.

Item 100300 will be available for nationwide sale on June 7, 2002. Item 781300 will be available at a later date.

The *Star* definitive stamp features a red, white, and blue graphic star.

How to Order the First Day of Issue Postmark

Customers have 30 days to obtain the first day of issue postmark by mail. They may purchase new stamps at their local Post Office, by telephone at 800-STAMP-24, and at the Postal Store Web site at www.usps.com. They should affix the stamps to envelopes of their choice, address the

envelopes (to themselves or others), and place them in a larger envelope addressed to:

STAR DEFINITIVE STAMP
 POSTMASTER
 SPECIAL CANCELLATIONS
 PO BOX 92282
 WASHINGTON DC 20090-2282

Issue:	<i>Star-Offset</i>
Item Number:	100300
Denomination & Type of Issue:	3-cent Definitive
Format:	Pane of 50 (1 design)
Series:	N/A
Issue Date & City:	June 7, 2002, Washington, DC 20066
Designer:	Phil Jordan, Falls Church, VA
Engraver:	N/A
Art Director:	Phil Jordan, Falls Church, VA
Typographer:	Phil Jordan, Falls Church, VA
Modeler:	Banknote Corporation of America, Inc. (BCA)
Manufacturing Process:	Offset (Banknote Corporation of America, Inc.)
Printer:	Banknote Corporation of America, Inc. (BCA)
Printed at:	Browns Summit, NC
Press Type:	Goebel, 670
Stamps per Pane:	50
Print Quantity:	2 billion stamps
Paper Type:	Nonphosphored type III
Adhesive Type:	Pressure Sensitive
Processed at:	BCA, Browns Summit, NC
Colors:	PMS 072 (Blue), PMS 032 (Red), Process Black
Stamp Orientation:	Vertical
Image Area (w x h):	0.70 x 0.80 in./17.78 x 20.32 mm
Overall Size (w x h):	0.84 x 0.99 in./21.34 x 25.15 mm
Pane Size (w x h):	9.31 x 5.63 in./236.47 x 143.00 mm
Plate Size:	400 stamps per revolution
Plate Numbers:	"B" followed by three (3) single digits
Marginal Markings:	"© 2002 USPS" • Plate numbers in four corners • Price • Plate position diagram • Barcode
Catalog Item Number(s):	100320 Block of 4 — \$0.12 100330 Block of 20 — \$0.60 100340 Full Pane of 50 — \$1.50 100362 First Day Cover — \$0.78

After applying the first day of issue postmark, the Postal Service will return the envelopes through the mail. There is no charge for the postmark. All orders must be postmarked by July 8, 2002.

Stamp Fulfillment Services (SFS) also offers first day covers for new stamp issues and Postal Service stationery items postmarked with the official first day of issue cancellation. Each item has an individual catalog number and is offered in the quarterly *USA Philatelic* catalog. Customers may request a free catalog by telephoning 800-STAMP-24 or writing to:

INFORMATION FULFILLMENT
DEPT 6270
US POSTAL SERVICE
PO BOX 219014
KANSAS CITY MO 64121-9014

First day covers remain on sale for at least 1 year after the stamp's issuance.

Philatelic Products

There are no philatelic products for this stamp issue.

Distribution: Item 100300, 3-Cent *Star*, Definitive Stamp, PSA Pane of 50

Stamp distribution offices (SDOs) will receive 2.5 billion 3-cent *Star* stamps, shipped in four waves. Two waves will be shipped from Banknote Corporation of America (BCA). BCA's wave 1 shipments began April 29, 2002, and completed May 15, 2002. BCA's wave 2 shipments will begin May 22, 2002, and will complete May 29, 2002.

Two additional waves will be shipped from Guilford Gravure Inc. (GGI). GGI's wave 1 shipments began May 1, 2002, and will complete May 16, 2002. GGI's wave 2 shipments will begin May 20, 2002, and will complete May 29, 2002.

Initial Supply to Post Offices

SDOs will make a subsequent automatic distribution to Post Offices for 10 times their standard automatic distribution quantities using PS Form 3309, *Advice of Shipment/Stamp Invoice*, and PS Form 17, *Stamp Requisition*. SDOs must not distribute stamps to Post Offices before May 28, 2002.

Philatelic Requirement

SDOs will not receive a separate quantity of this definitive stamp for their authorized philatelic centers. Philatelic centers must be supplied their quantities from the initial automatic distribution made to SDOs.

Additional Supply

Post Offices requiring additional stamps must requisition them from their designated SDO using PS Form 17. SDOs requiring additional stamps must order them from the appropriate accountable paper depository (APD) using PS Form 17.

For fulfilling supplemental orders from SDOs, the San Francisco, Chicago, Memphis, Washington, DC, and New York APDs will each receive 17,600,000 additional stamps, and the Denver APD will receive 8,890,000 additional stamps. For fulfilling supplemental orders from APDs, the Kansas City Stamp Services Center (SSC) will receive 385,440,000 additional stamps.

Issue:	<i>Star-Gravure</i>
Item Number:	100300
Denomination & Type of Issue:	3-cent Definitive
Format:	Pane of 50 (1 design)
Series:	N/A
Issue Date & City:	June 7, 2002, Washington, DC 20066
Designer:	Phil Jordan, Falls Church, VA
Engraver:	N/A
Art Director:	Phil Jordan, Falls Church, VA
Typographer:	Phil Jordan, Falls Church, VA
Modeler:	Banknote Corporation of America, Inc. (BCA)
Manufacturing Process:	Gravure (Guilford Gravure)
Printer:	Banknote Corporation of America, Inc. (BCA)
Printed at:	Guilford, CT
Press Type:	Cerrutti, R118
Stamps per Pane:	50
Print Quantity:	1 billion stamps
Paper Type:	Nonphosphored, Type III
Adhesive Type:	Pressure Sensitive
Processed at:	Guilford Gravure, Guilford, CT
Colors:	PMS 072 (Blue), PMS 032 (Red), Process Black
Stamp Orientation:	Vertical
Image Area (w x h):	0.70 x 0.80 in./17.78 x 20.32 mm
Overall Size (w x h):	0.84 x 0.99 in./21.34 x 25.15 mm
Pane Size (w x h):	9.31 x 5.63 in./236.47 x 143.00 mm
Plate Size:	400 stamps per revolution
Plate Numbers:	"B" followed by three (3) single digits
Marginal Markings:	"© USPS 2002" • Plate numbers in four corners • Price • Plate position diagram • Barcode
Catalog Item Number(s):	100440 Pane of 50 — \$1.50 100430 Block of 20 — \$0.60 100420 Block of 4 — \$0.12

Distribution: Item 781300, WAG Coil of 10,000

Distribution information will be supplied at a later date.

Issue:	<i>Star</i>
Item Number:	781300
Denomination & Type of Issue:	3-cent Definitive
Format:	Coil of 10,000 (1 design)
Series:	N/A
Issue Date & City:	June 7, 2002, Washington, DC 20066
Designer:	Phil Jordan, Falls Church, VA
Art Director:	Phil Jordan, Falls Church, VA
Typographer:	Phil Jordan, Falls Church, VA
Modeler:	Donald H. Woo
Manufacturing Process:	Gravure
Engraver:	Armotek Industries
Printer:	Sennett Security Products (SSP)
Printed at:	American Packaging Corporation, Columbus, WI
Press Type:	Rotomec, 3000
Stamps per coil:	10,000
Print Quantity:	400 million stamps
Paper Type:	Nonphosphored, Type III
Adhesive Type:	Water-activated gum
Processed at:	Unique Binders, Fredericksburg, VA
Colors:	PMS 032 (Red), PMS 072 (Blue), Black
Stamp Orientation:	Vertical
Image Area (w x h):	0.72 x 0.810 in./18.28 x 20.57 mm
Overall Size (w x h):	0.87 x 0.962 in./22.10 x 24.43 mm
Full Pane Size (w x h):	N/A
Plate Size:	616 stamps per revolution
Plate Numbers:	"S" followed by three (3) single digits (every 14 stamps)
Marginal Markings:	N/A
Catalog Item Number(s):	781320 Strip of 5 — \$0.15 781330 Strip of 25 w/plate no. — \$0.75 781340 Full Coil of 10,000 — \$300.00 781362 First Day Cover — \$0.75

— Stamp Services,
Government Relations and Public Policy, 5-16-02

STAMP ANNOUNCEMENT 02-11

U.S. Flag Definitive Stamp

Copyright USPS 2002

The Postal Service will issue a 37-cent *U.S. Flag* definitive stamp on June 7, 2002, in Washington, DC. The stamp was designed and illustrated by Terrence W. McCaffrey, U.S. Postal Service, Washington, DC. No official ceremony is planned.

The stamp will be issued in a pressure-sensitive adhesive (PSA) convertible book of 18 (Item 562600); PSA pane of 20 (Item 562900); PSA convertible book of 10 (Item 670600); PSA vending book of 20 (Item 670700); PSA double-sided book of 20 (Item 670800); PSA convertible book of 20 (Item 670900); PSA coil of 100 (Item 780100); PSA coil of 3,000 (Item 780200); PSA coil of 10,000 (Item 780300); water-activated gum (WAG) coil of 100 (Item 780500); WAG coil of 3,000 (Item 780600); and WAG coil of 10,000 (Item 780700). Items 780300 and 780600 will be available for nationwide sale on June 7, 2002. Items 562600, 562900, 670600, 670700, 670800, 670900, 780100, 780200, 780500 and 780700 will be available for sale at later date.

The stars and stripes of "Old Glory" are featured on this definitive stamp.

Issue:	<i>U.S. Flag</i>
Item Number:	562900
Denomination & Type of Issue:	37-cent Definitive
Format:	Pane of 20 (1 design)
Series:	N/A
Issue Date & City:	June 7, 2002, Washington, DC 20066
Designer:	Terrence W. McCaffrey, USPS, Washington, DC
Engraver:	N/A
Art Director:	Terrence W. McCaffrey, USPS, Washington, DC
Typographer:	Terrence W. McCaffrey, USPS, Washington, DC
Photograph:	Pictor International
Modeler:	Joseph Sheeran
Manufacturing Process:	Offset/Microprinting "USA"
Printer:	Ashton Potter USA Ltd. (APU)
Printed at:	Williamsville, NY
Press Type:	Stevens, Vari-size Security Press
Stamps per Pane:	20
Print Quantity:	100 million stamps
Paper Type:	Prephosphored, Type I
Adhesive Type:	Pressure Sensitive
Processed at:	Ashton Potter (USA) Ltd.
Colors:	Black, Cyan, Magenta, Yellow
Stamp Orientation:	Vertical
Image Area (w x h):	0.71 x 0.82 in./18.034 x 20.828 mm
Overall Size (w x h):	0.84 x 0.99 in./21.336 x 25.146 mm
Full Pane Size (w x h):	4.95 x 5.04 x in./125.73 x 128.01 mm
Plate Size:	240 stamps per revolution
Plate Numbers:	"P" followed by four (4) single digits
Marginal Markings:	"© 2002 USPS" • Plate block (4 positions) • Plate numbers • Price • Barcode
Catalog Item Number(s):	562920 Block of 4 — \$1.48 562930 Block of 10 — \$3.70 562940 Full Pane w/plate no. — \$7.40 562961 First Day Cover — \$0.75

How to Order the First Day of Issue Postmark

Customers have 90 days to obtain the first day of issue postmark by mail. They may purchase new stamps at their local Post Office, by telephone at 800-STAMP-24, and at the Postal Store Web site at www.usps.com. They should affix the stamps to envelopes of their choice, address the envelopes (to themselves or others), and place them in a larger envelope addressed to:

US FLAG STAMP
POSTMASTER
SPECIAL CANCELLATIONS
PO BOX 92282
WASHINGTON DC 20090-2282

After applying the first day of issue postmark, the Postal Service will return the envelopes through the mail. There is no charge for the postmark. All orders must be postmarked by September 5, 2002.

Stamp Fulfillment Services (SFS) also offers first day covers for new stamp issues and Postal Service stationery items postmarked with the official first day of issue cancellation. Each item has an individual catalog number and is offered in the quarterly *USA Philatelic* catalog. Customers may request a free catalog by telephoning 1 800 STAMP-24 or writing to:

INFORMATION FULFILLMENT
DEPT 6270
US POSTAL SERVICE
PO BOX 219014
KANSAS CITY MO 64121-9014

First day covers remain on sale for at least 1 year after the stamp's issuance.

Philatelic Products

There are no philatelic products for this stamp issue.

Distribution Item 780300, PSA Coil of 10,000

Stamp distribution offices (SDOs) *will not* receive an automatic distribution of Item 780300. Automatic distributions will be provided to accountable paper depositories (APDs) and stamp service centers (SSCs).

SDOs requiring quantities of Item 780300 must order them from the appropriate APD using a separate PS Form 17, *Stamp Requisition*. For fulfilling orders from SDOs, San Francisco, Chicago, Memphis, and New York APDs will each receive 2,000 coils, and the Denver APD will receive 880 coils. For fulfilling supplemental orders from APDs, the Kansas City SSC will receive 5,000 additional coils.

Initial Supply to Post Offices

Post Offices requiring quantities of Item 780300 must order them from their designated SDO using a separate PS Form 17. SDOs must not distribute these coils to Post Offices before May 28, 2002.

Philatelic Requirement

Authorized philatelic centers requiring Item 780300 must order from their designated SDO using PS Form 17.

Additional Supply

Post Offices requiring additional coils must requisition them from their designated SDO using a PS Form 17. SDOs requiring additional coils must order them from the appropriate APD using PS Form 17.

Distribution Item 780500, WAG Coil of 100

SDOs *will not* receive an automatic distribution of Item 780500. Automatic distributions will be provided to APDs and SSCs; however, these shipments will not be completed until June 26, 2002.

SDOs requiring quantities of Item 780500 must order them from the appropriate APD using a separate PS Form 17, *Stamp Requisition*. For fulfilling orders from SDOs, the San Francisco, Chicago, Memphis, and New York APDs will each receive 44,000 coils, and the Denver APD will receive 16,000 coils.

Initial Supply to Post Offices

Post Offices requiring quantities of Item 780500 must order them from their designated SDO using a separate PS Form 17. SDOs must not distribute these coils to Post Offices before May 28, 2002.

Philatelic Requirement

Authorized philatelic centers requiring Item 780500 must order from their designated SDO using PS Form 17.

Additional Supply

Post Offices requiring additional coils must requisition them from their designated SDO using a PS Form 17. SDOs requiring additional coils must order them from the appropriate APD using PS Form 17.

Distribution Item 780600, WAG Coil of 3,000

SDOs will receive two waves of automatic distributions for this definitive stamp in WAG coils of 3,000.

Wave 1 began shipment May 13, 2002, and will complete shipment May 28, 2002. Wave 2 will begin shipment June 11, 2002, and will complete shipment June 30, 2002. Master carton size is 64 coils.

Initial Supply to Post Offices

Post Offices requiring quantities of Item 780600 must order them from their designated SDO using a separate PS Form 17. SDOs must not distribute these coils to Post Offices before May 28, 2002.

Philatelic Requirement

Authorized philatelic centers requiring Item 780600 must order from their designated SDO using PS Form 17.

Additional Supply

Post Offices requiring additional coils must requisition them from their designated SDO using a PS Form 17. SDOs requiring additional coils must order them from the appropriate APD using PS Form 17.

For fulfilling supplemental orders from SDOs, the San Francisco, Chicago, Memphis, and New York APDs will each receive 6,000 coils, and the Denver APD will receive 2,880 coils. For fulfilling supplemental orders from APDs, the Kansas City SSC will receive 30,000 additional coils.

Distribution Item 780700, WAG Coil of 10,000

SDOs *will not* receive an automatic distribution of Item 780700. Automatic distributions will be provided to APDs and SSCs; however, these shipments will not be completed until June 26, 2002.

SDOs requiring quantities of Item 780700 must order them from the appropriate APD using separate PS Form 17, *Stamp Requisition*. For fulfilling orders from SDOs, the San Francisco, Chicago, Memphis, and New York APDs will each receive 900 coils, and the Denver APD will receive 300 coils.

Initial Supply to Post Offices

Post Offices requiring quantities of Item 780700 must order them from their designated SDO using a separate PS Form 17. SDOs must not distribute these coils to Post Offices before May 28, 2002.

Philatelic Requirement

Authorized philatelic centers requiring Item 780700 must order from their designated SDO using PS Form 17.

Additional Supply

Post Offices requiring additional coils must requisition them from their designated SDO using a PS Form 17. SDOs requiring additional coils must order them from the appropriate APD using PS Form 17.

Distribution Information for all the items listed below will be provided at a later time:

- Item 562900, PSA Pane of 20
- Item 670600, PSA Convertible Book of 10
- Item 670700, PSA Vending Book of 20
- Item 670800, PSA Double-sided Book of 20
- Item 670900, PSA Convertible Book of 20
- Item 780100, PSA Coil of 100
- Item 780200, PSA Coil of 3,000

Issue:	<i>U.S. Flag</i>
Item Number:	670600
Denomination & Type of Issue:	37-cent Definitive
Format:	Convertible Booklet of 10 (1 design)
Series:	N/A
Issue Date & City:	June 7, 2002, Washington, DC 20066
Photograph:	Pictor International
Designer:	Terrence W. McCaffrey, USPS, Washington, DC
Engraver:	Southern Graphics Systems
Art Director:	Terrence W. McCaffrey, USPS, Washington, DC
Typographer:	Terrence W. McCaffrey, USPS, Washington, DC
Modeler:	Avery Dennison, SPD
Manufacturing Process:	Gravure
Printer:	Avery Dennison (AVR)
Printed at:	AVR, Clinton, SC
Press Type:	Dia Nippon Kiko
Stamps per Booklet:	10
Print Quantity:	500 million stamps
Paper Type:	Pre-phosphored Type II
Adhesive Type:	Pressure Sensitive
Processed at:	AVR, Clinton, SC
Colors:	
Front:	Yellow, Cyan, Magenta, Black
Back:	Yellow, Magenta, Line 294 (Blue), Black
Stamp Orientation:	Vertical
Image Area (w x h):	0.720 x 0.832 in./18.288 x 21.133 mm
Overall Size (w x h):	0.870 x 0.982 in./22.098 x 24.948 mm
Full Booklet Size (w x h):	1.74 x 6.5 in./44.20 x 165.10 mm
Plate Size:	300 stamps per revolution
Plate Numbers:	"V" followed by four (4) single digits, (located on one stamp per booklet on bottom right corner).
Marginal Markings:	N/A
Catalog Item Number(s):	670640 Convertible Booklet of 10 — \$3.70

Issue:	<i>U.S. Flag</i>
Item Number:	670700
Denomination & Type of Issue:	37-cent Definitive
Format:	Vending Booklet of 20 (1 design)
Series:	N/A
Issue Date & City:	June 7, 2002, Washington, DC 20066
Designer:	Terrence W. McCaffrey, USPS, Washington, DC
Art Director:	Terrence W. McCaffrey, USPS, Washington, DC
Typographer:	Terrence W. McCaffrey, USPS, Washington, DC
Photograph:	Pictor International
Engraver:	Armotek Industries
Modeler:	Donald H. Woo
Manufacturing Process:	Gravure
Printer:	Sennett Security Products (SSP)
Printed at:	American Packaging Corporation, Columbus, WI
Press Type:	Rotomek, 3000
Stamps per Booklet:	20
Print Quantity:	200 million stamps
Paper Type:	Pre-phosphored Type II
Adhesive Type:	Pressure Sensitive
Processed at:	Unique Binders, Fredericksburg, VA
Colors:	Magenta, Cyan, Yellow, Black
Stamp Orientation:	Vertical
Image Area (w x h):	0.72 x 0.832 in./18.29 x 21.13 mm
Overall Size (w x h):	0.87 x 0.982 in./22.10 x 24.94 mm
Booklet Size (w x h) :	1.74 x 10.375 in /44.20 x 263.53 mm
Plate Size:	480 stamps per revolution
Plate Numbers:	"S" followed by four (4) single digits
Marginal Markings:	N/A
Catalog Item Number(s):	670740 Vending Booklet of 20 —\$7.40

Issue: *U.S. Flag (Double Sided)*
Item Number: 670800
Denomination & Type of Issue: 37-cent Definitive
Format: Convertible Booklet of 20 (1 design)
Series: N/A
Issue Date & City: June 7, 2002, Washington, DC 20066
Designer: Terrence W. McCaffrey, USPS, Washington, DC
Art Director: Terrence W. McCaffrey, USPS, Washington, DC
Typographer: Terrence W. McCaffrey, USPS, Washington, DC
Photograph: Pictor International
Engraver: Armotek Industries
Modeler: Donald H. Woo
Manufacturing Process: Gravure
Printer: Sennett Security Products (SSP)
Printed at: American Packaging Corporation, Columbus, WI
Press Type: Rotomek, 3000
Stamps per Booklet: 20
Print Quantity: 600 million stamps
Paper Type: Pre-phosphored Type II
Adhesive Type: Pressure Sensitive
Processed at: Unique Binders, Fredericksburg, VA
Colors: Magenta, Cyan, Yellow, Black
Stamp Orientation: Vertical
Image Area (w x h): 0.72 x 0.832 in./18.29 x 21.13 mm
Overall Size (w x h): 0.87 x 0.982 in./22.09 x 24.94 mm
Booklet Size (w x h) : 1.74 x 6.208 in /44.20 x 157.68 mm
Plate Size: 480 stamps per revolution
Plate Numbers: "S" followed by four (4) single digits
Marginal Markings: "© 2002 USPS" • Price • Plate numbers • "Peel here to fold" • Self-adhesive stamps • DO NOT WET • Double sided"
Catalog Item Number(s): 670840 PSA Double Sided Booklet of 20 — \$7.40

Issue: *U.S. Flag*
Item Number: 670900
Denomination & Type of Issue: 37-cent Definitive
Format: Convertible Booklet of 20 (1 design)
Series: N/A
Issue Date & City: June 7, 2002, Washington, DC 20066
Designer: Terrence W. McCaffrey, USPS, Washington, DC
Engraver: N/A
Art Director: Terrence W. McCaffrey, USPS, Washington, DC
Typographer: Terrence W. McCaffrey, USPS, Washington, DC
Photograph: Pictor International
Modeler: Banknote Corporation of America, Inc. (BCA)
Manufacturing Process: Offset/Microprinting "USPS"
Printer: Banknote Corporation of America, Inc. (BCA)
Printed at: BCA, Browns Summit, NC
Press Type: Goebel, 670
Stamps per Booklet: 20
Print Quantity: 1.8 billion stamps
Paper Type: Pre-phosphored, Type I
Adhesive Type: Pressure Sensitive
Processed at: BCA, Browns Summit, NC
Colors:
Front: Black, Cyan, Magenta, Yellow @ 300 Line screen
Back: Black, Cyan, Magenta, Yellow, Spec. PMS 294 (Blue) @ 200 Line screen
Stamp Orientation: Vertical
Image Area (w x h): 0.72 x 0.83 in./18.29 x 21.08 mm
Overall Size (w x h): 0.87 x 0.98 in./22.10 x 24.89 mm
Booklet Size (w x h) : 4.35 x 4.13 in./110.49 x 104.90
Plate Size: 500 stamps per revolution
Plate Numbers: "B" followed by four (4) single digits
Marginal Markings: "© USPS 2002" • Plate numbers • Price • "Peel here to fold" • Self-adhesive stamps • (cover side) barcode; U.S. Flag; misc. text • "DO NOT WET"
Catalog Item Number(s): 670940 Convertible Booklet of 20 — \$7.40
670961 First Day Cover — \$0.75

Issue: *U.S. Flag*
 Item Number: 780100
 Denomination & Type of Issue: 37-cent Definitive
 Format: Self-adhesive Coil of 100 (1 design)
 Series: N/A
 Issue Date & City: June 7, 2002, Washington, DC 20066
 Photograph: Pictor International
 Designer: Terrence W. McCaffrey, USPS, Washington, DC
 Engraver: N/A
 Art Director: Terrence W. McCaffrey, USPS, Washington, DC
 Typographer: Terrence W. McCaffrey, USPS, Washington, DC
 Modeler: Bureau of Engraving and Printing (BEP)
 Manufacturing Process: Gravure
 Printer: Bureau of Engraving and Printing (BEP)
 Printed at: BEP, Washington, DC
 Press Type: Andreotti, 601
 Stamps per Coil: 100
 Print Quantity: 2.9 billion stamps
 Paper Type: Pre-phosphored Type II
 Adhesive Type: Pressure Sensitive
 Processed at: BEP, Washington, DC
 Colors: Magenta, Cyan, Yellow, Black
 Stamp Orientation: Vertical
 Image Area (w x h): 0.71 x 0.82 in./18.33 x 20.82 mm
 Overall Size (w x h): 0.84 x 0.99 in./21.33 x 25.1 mm
 Full Pane Size (w x h): N/A
 Plate Size: 480 stamps per revolution
 Plate Numbers: Four (4) single digits
 Marginal Markings: N/A
 Catalog Item Number(s): 780140 Full Coil of 100 — \$37.00

Issue: *U.S. Flag*
 Item Number: 780200
 Denomination & Type of Issue: 37-cent Definitive
 Format: Coil of 3,000 (1 design)
 Series: N/A
 Issue Date & City: June 07, 2002, Washington, DC 20066
 Photograph: Pictor International
 Designer: Terrence W. McCaffrey, USPS, Washington, DC
 Engraver: Acitronics
 Art Director: Terrence W. McCaffrey, USPS, Washington, D
 Typographer: Terrence W. McCaffrey, USPS, Washington, DC
 Modeler: Guilford Gravure
 Manufacturing Process: Gravure
 Printer: Banknote Corporation of America, Inc. (BCA)
 Printed at: Guilford, CT
 Press Type: Cerrutti, R118
 Stamps per Coil: 3,000
 Print Quantity: 50 million stamps
 Paper Type: Nonphosphored type I
 Adhesive Type: Pressure Sensitive
 Processed at: Guilford, CT
 Colors: Magenta, Cyan, Yellow, Black
 Stamp Orientation: Vertical
 Image Area (w x h): 0.710 x 0.820 in./18.03 x 20.83 mm
 Overall Size (w x h): 0.870 x 0.982 in./ 22.10 x 24.94 mm
 Full Pane Size (w x h): N/A
 Plate Size: 400 stamps per revolution
 Plate Numbers: "B" followed by four (4) single digits
 Marginal Markings: "© 2001 USPS" • Plate numbers • Back number every 10th stamp
 Catalog Item Number(s): 780240 Full Coil of 3,000 — \$1,110.00
 780230 Strip of 25 w/plate no. — \$9.25

Issue: *U.S. Flag*
Item Number: 780300
Denomination & Type of Issue: 37-cent Definitive
Format: Coil of 10,000 (1 design)
Series: N/A
Issue Date & City: June 07, 2002, Washington, DC 20066
Photograph: Pictor International
Designer: Terrence W. McCaffrey, USPS, Washington, DC
Engraver: Acitronics
Art Director: Terrence W. McCaffrey, USPS, Washington, D
Typographer: Terrence W. McCaffrey, USPS, Washington, DC
Modeler: Guilford Gravure
Manufacturing Process: Gravure
Printer: Banknote Corporation of America, Inc. (BCA)
Printed at: Guilford, CT
Press Type: Cerrutti, R118
Stamps per Coil: 10,000
Print Quantity: 200 million stamps
Paper Type: Nonphosphored type I
Adhesive Type: Pressure Sensitive
Processed at: Guilford, CT
Colors: Magenta, Cyan, Yellow, Black
Stamp Orientation: Vertical
Image Area (w x h): 0.710 x 0.820 in./18.03 x 20.83 mm
Overall Size (w x h): 0.870 x 0.982 in./22.10 x 24.94 mm
Full Pane Size (w x h): N/A
Plate Size: 400 stamps per revolution
Plate Numbers: "B" followed by four (4) single digits
Marginal Markings: "© 2001 USPS" • Plate numbers • Back number every 10th stamp
Catalog Item Number(s): 780340 Full Coil of 10,000 — \$3,700.00
780330 Strip of 25 w/plate no. — \$9.25
780361 First Day Cover — \$0.75

Issue: *U.S. Flag*
Item Number: 780500
Denomination & Type of Issue: 37-cent Definitive
Format: Coil of 100 (1 design)
Series: N/A
Issue Date & City: June 7, 2002, Washington, DC 20066
Photograph: Pictor International
Designer: Terrence W. McCaffrey, USPS, Washington, DC
Art Director: Terrence W. McCaffrey, USPS, Washington, DC
Typographer: Terrence W. McCaffrey, USPS, Washington, DC
Modeler: Donald H. Woo
Manufacturing Process: Gravure
Engraver: Armotek Industries
Printer: Sennett Security Products (SSP)
Printed at: American Packaging Corporation, Columbus, WI
Press Type: Rotomec, 3000
Stamps per coil: 100
Print Quantity: 25 million stamps
Paper Type: Prephosphored, Type II
Adhesive Type: Water-Activated
Processed at: Unique Binders, Fredericksburg, VA
Colors: Magenta, Cyan, Yellow, Black
Stamp Orientation: Vertical
Image Area (w x h): 0.72 x 0.810 in./18.28 x 20.57 mm
Overall Size (w x h): 0.87 x 0.962 in./22.10 x 24.43 mm
Full Pane Size (w x h): N/A
Plate Size: 616 stamps per revolution
Plate Numbers: "S" followed by four (4) single digits (every 14 stamps)
Marginal Markings: N/A
Catalog Item Number(s): 780540 Full Coil of 100 — \$37.00
780530 Strip of 25 w/plate no. — \$9.25
780520 Strip of 5 — \$1.85

Issue: *U.S. Flag*
 Item Number: 780600
 Denomination & Type of Issue: 37-cent Definitive
 Format: Coil of 3,000 (1 design)
 Series: N/A
 Issue Date & City: June 7, 2002, Washington, DC 20066
 Photograph: Pictor International
 Designer: Terrence W. McCaffrey, USPS, Washington, DC
 Art Director: Terrence W. McCaffrey, USPS, Washington, DC
 Typographer: Terrence W. McCaffrey, USPS, Washington, DC
 Modeler: Donald H. Woo
 Manufacturing Process: Gravure
 Engraver: Armotek Industries
 Printer: Sennett Security Products (SSP)
 Printed at: American Packaging Corporation, Columbus, WI
 Press Type: Rotomec, 3000
 Stamps per coil: 3,000
 Print Quantity: 300 million stamps
 Paper Type: Prephosphored, Type II
 Adhesive Type: Water-Activated
 Processed at: Unique Binders, Fredericksburg, VA
 Colors: Magenta, Cyan, Yellow, Black
 Stamp Orientation: Vertical
 Image Area (w x h): 0.72 x 0.810 in./18.28 x 20.57 mm
 Overall Size (w x h): 0.87 x 0.962 in./22.10 x 24.43 mm
 Full Pane Size (w x h): N/A
 Plate Size: 616 stamps per revolution
 Plate Numbers: "S" followed by four (4) single digits (every 14 stamps)
 Marginal Markings: N/A
 Catalog Item Number(s): 780620 Strip of 5 — \$1.85
 780630 Strip of 25 w/plate no. — \$9.25
 780640 Full Coil of 3,000 — \$1,110.00

Issue: *U.S. Flag*
 Item Number: 780700
 Denomination & Type of Issue: 37-cent Definitive
 Format: Coil of 10,000 (1 design)
 Series: N/A
 Issue Date & City: June 7, 2002, Washington, DC 20066
 Photograph: Pictor International
 Designer: Terrence W. McCaffrey, USPS, Washington, DC
 Art Director: Terrence W. McCaffrey, USPS, Washington, DC
 Typographer: Terrence W. McCaffrey, USPS, Washington, DC
 Modeler: Donald H. Woo
 Manufacturing Process: Gravure
 Engraver: Armotek Industries
 Printer: Sennett Security Products (SSP)
 Printed at: American Packaging Corporation, Columbus, WI
 Press Type: Rotomec, 3000
 Stamps per coil: 10,000
 Print Quantity: 50 million stamps
 Paper Type: Prephosphored, Type II
 Adhesive Type: Water-Activated
 Processed at: Unique Binders, Fredericksburg, VA
 Colors: Magenta, Cyan, Yellow, Black
 Stamp Orientation: Vertical
 Image Area (w x h): 0.72 x 0.810 in./18.28 x 20.57 mm
 Overall Size (w x h): 0.87 x 0.962 in./22.10 x 24.43 mm
 Full Pane Size (w x h): N/A
 Plate Size: 616 stamps per revolution
 Plate Numbers: "S" followed by four (4) single digits (every 14 stamps)
 Marginal Markings: N/A
 Catalog Item Number(s): 780720 Strip of 5 — \$1.85
 780730 Strip of 25 w/plate no. — \$9.25
 780740 Full Coil of 10,000 — \$3,700.00
 780761 First Day Cover — \$0.75

STAMP ANNOUNCEMENT 02-12

U.S. Flag Nondenominated Definitive Stamp

Copyright USPS 2002

The Postal Service will issue a *U.S. Flag* nondenominated definitive stamp (37-cent value) on June 7, 2002, in Washington, DC. The stamp, designed and illustrated by Terrence W. McCaffrey, U.S. Postal Service, Washington, DC, goes on sale nationwide June 7, 2002. No official ceremony is planned.

The stamp will be issued in a water-activated (WAG) pane of 100 (Item 103800); pressure-sensitive adhesive (PSA) automated teller machine (ATM) sheetlet of 18 (Item 563100); PSA pane of 20 (Item 563200); PSA convertible book of 20 (Item 671100); PSA vending book of 20 (Items 671200 and 671211); PSA double-sided book of 20 (Item 671600); and a PSA coil of 100 (Item 781100).

The stars and stripes of "Old Glory" are featured on this definitive stamp.

How to Order the First Day of Issue Postmark

Customers have 30 days to obtain the first day of issue postmark by mail. They may purchase new stamps at their local Post Office, by telephone at 800-STAMP-24, and at the Postal Store Web site at www.usps.com. They should affix the stamps to envelopes of their choice,

address the envelopes (to themselves or others), and place them in a larger envelope addressed to:

US FLAG NONDENOMINATED DEFINITIVE STAMP
POSTMASTER
SPECIAL CANCELLATIONS
PO BOX 92282
WASHINGTON DC 20090-2282

After applying the first day of issue postmark, the Postal Service will return the envelopes through the mail. There is no charge for the postmark. All orders must be postmarked by July 8, 2002.

Issue:	<i>U.S. Flag</i>
Item Number:	103800
Denomination & Type of Issue:	Nondenominated Definitive
Format:	Pane of 100 (1 design)
Series:	N/A
Issue Date & City:	June 7, 2002, Washington, DC 20066
Designer:	Terrence W. McCaffrey, USPS, Washington, DC
Engraver:	N/A
Art Director:	Terrence W. McCaffrey, USPS, Washington, DC
Typographer:	Terrence W. McCaffrey, USPS, Washington, DC
Photograph:	Pictor International
Modeler:	Joseph Sheeran
Manufacturing Process:	Offset/Microprinting "USA"
Printer:	Sterling Sommer
Printed at:	Tonawanda, NY
Press Type:	Heidelberg, 840
Stamps per Pane:	100
Print Quantity:	35 million stamps
Paper Type:	Nonphosphored, Type III
Adhesive Type:	Water-Activated
Processed at:	Ashton Potter (USA) Ltd.
Colors:	Black, Cyan, Magenta, Yellow
Stamp Orientation:	Vertical
Image Area (w x h):	0.71 x 0.82 in./18.034 x 20.828 mm
Overall Size (w x h):	0.84 x 0.99 in./21.336 x 25.146 mm
Full Pane Size (w x h):	9 x 10.18 x in./228.60 x 258.57 mm
Plate Size:	400 stamps per revolution
Plate Numbers:	"P" followed by four (4) single digits
Marginal Markings:	"© 2002 USPS" • Plate block (4 positions) • Plate numbers • Barcode
Catalog Item Number(s):	113820 Block of 4 — \$1.48 113830 Block of 20 w/plate no. — \$7.40 113840 Full Pane — \$37.00 113861 First Day Cover — \$0.75

Stamp Fulfillment Services (SFS) also offers first day covers for new stamp issues and Postal Service stationery items postmarked with the official first day of issue cancellation. Each item has an individual catalog number and is offered in the quarterly *USA Philatelic* catalog. Customers may request a free catalog by telephoning 800-STAMP-24 or writing to:

INFORMATION FULFILLMENT
DEPT 6270
US POSTAL SERVICE
PO BOX 219014
KANSAS CITY MO 64121-9014

First day covers remain on sale for at least 1 year after the stamp's issuance.

Philatelic Products

There are no philatelic products for this stamp issue.

Distribution: Item 103800, WAG Pane of 100

The U.S. Flag water-activated gum (WAG) pane of 100 *will not* be automatically distributed to stamp distribution offices (SDOs). SDOs requiring item 103800 must order them from the appropriate accountable paper depository (APD) using PS Form 17, *Stamp Requisition*. Automatic distributions will be made to APDs only. Distributions are rounded up to the nearest master carton size (250,000 stamps).

Initial Supply to Post Offices

SDOs *will not* make a subsequent automatic distribution to Post Offices. Post Offices requiring quantities of item 103800 must order them from their designated SDO using a separate PS Form 17. SDOs must not distribute philatelic quantities to Post Offices before May 28, 2002.

Additional Supply

Post Offices requiring additional stamps must requisition them from their designated SDO using PS Form 17.

SDOs requiring additional stamps must order them from the appropriate APD using PS Form 17.

Philatelic Centers

Philatelic centers requiring Item 103800 must order them from their designated SDO using PS Form 17.

Distribution: Item 563100, ATM PSA Sheetlet of 18

Most SDOs *will not* receive a standard automatic distribution quantity of the *U.S. Flag* ATM sheetlet. SDOs will, however, receive automatic distribution of "philatelic stock" only, for subsequent distribution to their authorized philatelic centers (see Philatelic Requirement below). Select SDOs with established ATM stamp demand will receive an automatic distribution of Item 563100, and

additional distributions will be provided to APDs and stamp services centers (SSCs). Distributions will be in two waves. Wave 1 shipments began May 6, 2002, and will complete May 24, 2002. Wave 2 shipments are scheduled to begin July 8, 2002, and will complete August 9, 2002.

Initial Supply to Post Offices

Post Offices requiring quantities of Item 563100 to meet the needs of authorized ATM customers must order them from their designated SDO using a separate PS Form 17, *Stamp Requisition*. SDOs must not distribute sheetlets to Post Offices before May 28, 2002.

Philatelic Requirement

SDOs with authorized philatelic centers will receive an automatic distribution of 200 ATM sheetlets per each philatelic window.

SDOs That Serve This Many Philatelic Windows...	Will Receive This Quantity of the U.S. Flag ATM Sheetlet, Item 563100...
1	200
2	400
3	600
4	800
5	1,000
6	1,200
7	1,400
8	1,600
9	1,800
12	2,400
13	2,600
16	3,200
19	3,800

Additional Supply

Post Offices requiring additional ATM stamp sheetlets to meet the needs of authorized ATM customers must requisition them from their designated SDO using PS Form 17. SDOs requiring additional stamps must order them from the appropriate APD using PS Form 17.

For fulfilling supplemental orders from SDOs, the San Francisco, Chicago, Memphis, and New York APDs will each receive 240,000 sheetlets, and the Denver APD will receive 120,000 sheetlets.

Distribution: Item 563200, PSA, Pane of 20

SDOs will receive a full standard automatic distribution for a PSA sheet stamp. Distributions are rounded up to the nearest carton size (40,000 stamps).

Initial Supply to Post Offices

SDOs will make a subsequent automatic distribution to Post Offices for their full standard automatic distribution quantities using PS Form 3309, *Advice of Shipment/Stamp*

Invoice, and PS Form 17, *Stamp Requisition*. SDOs must not distribute stamps to Post Offices before May 28, 2002.

Philatelic Requirement

SDOs will not receive a separate quantity of this definitive stamp for their authorized philatelic centers. Philatelic centers must be supplied their quantities from the initial automatic distribution made to SDOs.

Additional Supply

Post Offices requiring additional stamps must requisition them from their designated SDO using PS Form 17. SDOs requiring additional stamps must order them from the appropriate APD using PS Form 17.

For fulfilling supplemental orders from SDOs, the San Francisco, Chicago, Memphis, Washington, DC, and New York APDs will each receive 4,000,000 additional stamps, and the Denver APD will receive 2,000,000 additional stamps.

Distribution: Item 671100, PSA Convertible Booklet of 20

SDOs will receive an approximate full standard distribution of the convertible booklet of 20 stamps. Distributions are rounded up to nearest master carton size (4,000 booklets).

Initial Supply to Post Offices

SDOs will make a subsequent automatic distribution to Post Offices for their full standard automatic distribution quantities using PS Form 3309, *Advice of shipment, Stamp Invoice*, and PS Form 17, *Stamp Requisition*. SDOs must not distribute booklets to Post Offices before May 28, 2002.

Philatelic Requirement

SDOs *will not* receive a separate quantity of this definitive stamp for their authorized philatelic centers. Philatelic centers must be supplied their quantities from the initial automatic distribution made to SDOs.

Additional Supply

Post Offices requiring additional booklets must requisition them from their designated SDO using PS Form 17.

Additional quantities *will not* be available at APDs for supplemental ordering by SDOs.

Distribution: Items 671200 and 671211, PSA Folded Book of 20 (Vending Use Only)

SDOs will receive an automatic distribution quantity of these vending books of 20. Distributions are rounded up to the nearest master carton size (4,500 books for straight; 3,000 books for criss-cross).

Initial Supply to Post Offices

SDOs *will not* make a subsequent automatic distribution to Post Offices. Only Post Offices equipped with the appropriate self-service vending machines may order these items from their designated SDO using a separate PS Form 17. SDOs must not distribute books to Post Offices before May 28, 2002.

Additional Supply

Authorized Post Offices, requiring additional books for restocking of the appropriate self-service vending machines, must requisition them from their designated SDO using PS Form 17.

Additional quantities *will not* be available at APDs for supplemental ordering by SDOs.

Distribution: Item 671600, PSA Double-Sided Booklet of 20

SDOs *will not* receive a standard automatic distribution quantity of the *U.S. Flag* double-sided booklet. SDOs will, however, receive automatic distribution of "philatelic stock" only, for subsequent distribution to their authorized philatelic centers (see Philatelic Requirement below).

Initial Supply to Post Offices

Produced primarily for the Retail consignment program, administered by American Banknote Corporation, this double-sided booklet format will not be available to Post Offices other than those authorized Philatelic center quantities listed below. SDOs must not distribute philatelic quantities to Post Offices before May 28, 2002.

Philatelic Requirement

SDOs with authorized philatelic centers will receive an automatic distribution of 200 double-sided booklets per each philatelic window.

SDOs That Serve This Many Philatelic Windows...	Will Receive This Quantity of the <i>U.S. Flag</i> Nondenominated Double-sided Book of 20 Item 671600...
1	200
2	400
3	600
4	800
5	1,000
6	1,200
7	1,400
8	1,600
9	1,800
12	2,400
13	2,600
16	3,200
19	3,800

Additional Supply

There will be no additional booklets available at SDOs for supplemental ordering by Post Offices.

Additional quantities *will not* be available at APDs for supplemental ordering by SDOs.

Distribution: Item 781100, Nondenominated Flag, Definitive Stamp, PSA Coil of 100

SDOs will receive two waves of automatic distributions for this definitive stamp in PSA coils of 100. Wave 1 began shipment April 29, 2002, and will complete shipment May 18, 2002. Wave 2 will begin shipment May 20, 2002, and will complete shipment June 21, 2002. Master carton size is 800 coils.

Initial Supply for Post Offices

SDOs *will not* make a subsequent automatic distribution to Post Offices. All Post Offices requiring quantities of Item 7781100 must order them from their designated SDO using a separate PS Form 17, *Stamp Requisition*. SDOs must not distribute coils to Post Offices before May 28, 2002.

Philatelic Requirement

SDOs *will not* receive a separate quantity of this definitive stamp for their authorized philatelic centers. Philatelic centers must be supplied their quantities from the initial automatic distribution made to SDOs.

Additional Supply

Post Offices requiring additional stamps must requisition them from their designated SDO using PS Form 17. SDOs requiring additional stamps must order them from the appropriate APD using PS Form 17.

For fulfilling supplemental orders from SDOs, the San Francisco, Chicago, Memphis, and New York APDs will each receive 480,000 additional coils, and the Denver APD will receive 240,000 additional coils. APD distributions will ship following completion of the Wave 2 automatic distribution to SDOs.

Additional quantities *will not* be available at the Bureau of Engraving and Printing (BEP) for supplemental ordering by SDOs or APDs.

Issue:	<i>U.S. Flag</i>
Item Number:	563100
Denomination & Type of Issue:	Nondenominated, Definitive
Format:	ATM Sheetlet, Convertible Book of 18 (1 design)
Series:	N/A
Issue Date & City:	June 7, 2002, Washington, DC 20066
Photograph:	Pictor International
Designer:	Terrence W. McCaffrey, USPS, Washington, DC
Engraver:	Southern Graphic Systems
Art Director:	Terrence W. McCaffrey, USPS, Washington, DC
Typographer:	Terrence W. McCaffrey, USPS, Washington, DC
Modeler:	Avery Dennison, SPD
Manufacturing Process:	Gravure
Printer:	Avery Dennison, (AVR)
Printed at:	AVR, Clinton, SC
Press Type:	Dia Nippon Kiko (DNK)
Stamps per Pane:	18
Print Quantity:	300 million stamps
Paper Type:	Non-phosphored, Type III
Adhesive Type:	Pressure Sensitive
Processed at:	AVR, Clinton, SC
Colors:	Yellow, Cyan, Magenta, Black
Stamp Orientation:	Vertical
Image Area (w x h):	0.818 x 0.720 in./20.777 x 18.288 mm
Overall Size (w x h):	0.982 x 0.870 in./24.943 x 22.098 mm
Full Booklet Size (w x h):	2.61 x 6.125 in./66.294 x 165.1 mm
Plate Size:	5 books across x 6 books around (30 per press sheet)
Plate Numbers:	"V" followed by four (4) single digits
Marginal Markings:	"Peel here to fold" • "Self-adhesive stamps" • "DO NOT WET" • color registration dots
Catalog Item Number(s):	563140 Single Sheetlet — \$6.66 563161 First Day cover — \$0.75

Issue: *U.S. Flag*
Item Number: 563200
Denomination & Type of Issue: Nondenominated Definitive
Format: Pane of 20 (1 design)
Series: N/A
Issue Date & City: June 7, 2002, Washington, DC 20066
Designer: Terrence W. McCaffrey, USPS, Washington, DC
Engraver: N/A
Art Director: Terrence W. McCaffrey, USPS, Washington, DC
Typographer: Terrence W. McCaffrey, USPS, Washington, DC
Photograph: Pictor International
Modeler: Joseph Sheeran
Manufacturing Process: Offset/Microprinting "USA"
Printer: Ashton Potter USA Ltd. (APU) Williamsville, NY
Press Type: Stevens, Vari-size Security Press
Stamps per Pane: 20
Print Quantity: 100 million stamps
Paper Type: Prephosphored, Type I
Adhesive Type: Pressure Sensitive
Processed at: Ashton Potter (USA) Ltd.
Colors: Black, Cyan, Magenta, Yellow
Stamp Orientation: Vertical
Image Area (w x h): 0.71 x 0.82 in./18.034 x 20.828 mm
Overall Size (w x h): 0.84 x 0.99 in./21.336 x 25.146 mm
Full Pane Size (w x h): 4.95 x 5.04 x in./125.73 x 128.01 mm
Plate Size: 240 stamps per revolution
Plate Numbers: "P" followed by four (4) single digits
Marginal Markings: "© 2002 USPS" • Plate block (4 positions) • Plate numbers • Barcode
Catalog Item Number(s): 563220 Block of 4 — \$1.48
563230 Block of 10 — \$3.70
563240 Full Pane w/plate no. — \$7.40
563261 First Day Cover — \$0.75

Issue: *U.S. Flag*
Item Number: 671100
Denomination & Type of Issue: Nondenominated
Format: Convertible Booklet of 20 (1 design)
Series: N/A
Issue Date & City: June 7, 2002, Washington, DC 20066
Designer: Terrence W. McCaffrey, USPS, Washington, DC
Engraver: N/A
Art Director: Terrence W. McCaffrey, USPS, Washington, DC
Typographer: Terrence W. McCaffrey, USPS, Washington, DC
Photograph: Pictor International
Modeler: Banknote Corporation of America, Inc. (BCA)
Manufacturing Process: Offset/Microprinting "USPS"
Printer: Banknote Corporation of America, Inc. (BCA)
Printed at: BCA, Browns Summit, NC
Press Type: Goebel, 670
Stamps per Booklet: 20
Print Quantity: 1.2 billion stamps
Paper Type: Pre-phosphored, Type I
Adhesive Type: Pressure Sensitive
Processed at: BCA, Browns Summit, NC
Colors:
Front: Black, Cyan, Magenta, Yellow @ 300 Line screen
Back: Black, Cyan, Magenta, Yellow, Spec. PMS 294 (Blue) @ 200 Line screen
Stamp Orientation: Vertical
Image Area (w x h): 0.72 x 0.83 in./18.29 x 21.08 mm
Overall Size (w x h): 0.87 x 0.98 in./22.10 x 24.89 mm
Booklet Size (w x h) : 4.35 x 4.13 in./110.49 x 104.90
Plate Size: 500 stamps per revolution
Plate Numbers: "B" followed by four (4) single digits
Marginal Markings: "© USPS 2002" • Plate numbers • Price • "Peel here to fold" • Self-adhesive stamps (cover side) barcode; U.S. Flag; misc. text • "DO NOT WET"
Catalog Item Number(s): 671140 Convertible Booklet of 20 — \$7.40
671161 First Day Cover — \$0.75

Issue: *U.S. Flag*
 Item Number: 671200
 Denomination & Type of Issue: Nondenominated, Definitive
 Format: Vending Booklet of 20 (1 design)
 Series: N/A
 Issue Date & City: June 7, 2002, Washington, DC 20066
 Designer: Terrence W. McCaffrey, USPS, Washington, DC
 Art Director: Terrence W. McCaffrey, USPS, Washington, DC
 Typographer: Terrence W. McCaffrey, USPS, Washington, DC
 Photograph: Pictor International
 Engraver: Armotek Industries
 Modeler: Donald H. Woo
 Manufacturing Process: Gravure
 Printer: Sennett Security Products (SSP)
 Printed at: American Packaging Corporation, Columbus, WI
 Press Type: Rotomek, 3000
 Stamps per Booklet: 20
 Print Quantity: 300 million stamps
 Paper Type: Pre-phosphored Type II
 Adhesive Type: Pressure Sensitive
 Processed at: Unique Binders, Fredericksburg, VA
 Colors: Magenta, Cyan, Yellow, Black
 Stamp Orientation: Vertical
 Image Area (w x h): 0.72 x 0.832 in./18.29 x 21.13 mm
 Overall Size (w x h): 0.87 x 0.982 in./22.10 x 24.94 mm
 Booklet Size (w x h) : 1.74 x 10.375 in /44.20 x 263.53 mm
 Plate Size: 480 stamps per revolution
 Plate Numbers: "S" followed by four (4) single digits
 Marginal Markings: N/A
 Catalog Item Number(s): 671240 Vending Booklet of 20 — \$7.40

Issue: *U.S. Flag (Double Sided)*
 Item Number: 671600
 Denomination & Type of Issue: Nondenominated, Definitive
 Format: Convertible Booklet of 20 (1 design)
 Series: N/A
 Issue Date & City: June 7, 2002, Washington, DC 20066
 Designer: Terrence W. McCaffrey, USPS, Washington, DC
 Art Director: Terrence W. McCaffrey, USPS, Washington, DC
 Typographer: Terrence W. McCaffrey, USPS, Washington, DC
 Photograph: Pictor International
 Engraver: Armotek Industries
 Modeler: Donald H. Woo
 Manufacturing Process: Gravure
 Printer: Sennett Security Products (SSP)
 Printed at: American Packaging Corporation, Columbus, WI
 Press Type: Rotomek, 3000
 Stamps per Booklet: 20
 Print Quantity: 400 million stamps
 Paper Type: Pre-phosphored Type II
 Adhesive Type: Pressure Sensitive
 Processed at: Unique Binders, Fredericksburg, VA
 Colors: Magenta, Cyan, Yellow, Black
 Stamp Orientation: Vertical
 Image Area (w x h): 0.72 x 0.832 in./18.29 x 21.13 mm
 Overall Size (w x h): 0.87 x 0.982 in./22.09 x 24.94 mm
 Booklet Size (w x h) : 1.74 x 6.208 in /44.20 x 157.68 mm
 Plate Size: 480 stamps per revolution
 Plate Numbers: "S" followed by four (4) single digits
 Marginal Markings: "© 2002 USPS" • Price • Plate numbers • "Peel here to fold • Self-adhesive stamps • DO NOT WET • Double sided"
 Catalog Item Number(s): 671640 PSA Double Sided Booklet of 20 — \$7.40

Issue:	<i>U.S. Flag</i>
Item Number:	781100
Denomination & Type of Issue:	Nondenominated
Format:	Coil of 100 (1 design)
Series:	N/A
Issue Date & City:	June 7, 2002, Washington, DC 20066
Designer:	Terrence W. McCaffrey, USPS, Washington, DC
Engraver:	N/A
Art Director:	Terrence W. McCaffrey, USPS, Washington, DC
Typographer:	Terrence W. McCaffrey, USPS, Washington, DC
Modeler:	Bureau of Engraving and Printing (BEP)
Manufacturing Process:	Gravure
Printer:	Bureau of Engraving and Printing (BEP)
Printed at:	BEP, Washington, DC
Press Type:	Andreotti, 601
Stamps per Coil:	100
Print Quantity:	2.5 billion stamps
Paper Type:	Pre-phosphored Type II
Adhesive Type:	Pressure Sensitive
Processed at:	BEP, Washington, DC
Colors:	Magenta, Cyan, Yellow, Black
Stamp Orientation:	Vertical
Image Area (w x h):	0.71 x 0.82 in./18.33 x 20.82 mm
Overall Size (w x h):	0.84 x 0.99 in./21.33 x 25.1 mm
Full Pane Size (w x h):	N/A
Plate Size:	480 stamps per revolution
Plate Numbers:	Four (4) single digits
Marginal Markings:	N/A
Catalog Item Number(s):	781140 Full Coil of 100 — \$37.00 781130 Strip of 25 w/plate no. — \$9.25

— *Stamp Services,*
Government Relations and Public Policy, 5-16-02

STAMP ANNOUNCEMENT 02-13

Antique Toys Stamps



Copyright USPS 2001

The Postal Service will issue a nondenominated *Antique Toys* definitive stamp (37-cent value) in a pressure-sensitive adhesive (PSA) vending booklet of 20 (Item 671400) and a PSA convertible booklet of 20 (Item 671500) on June 7, 2002, in Washington, DC. The stamp, designed by Derry Noyes, Washington, DC, and photographed by Sally Andersen-Bruce, New Milford, Connecticut, will go on sale nationwide on June 7, 2002.

The *Antique Toys* definitive stamp features four antique American toy vehicles from the Strong Museum in Rochester, New York: a bright red U.S. Mail truck with a spring wound mechanism, a yellow taxicab, a mechanical locomotive of cast iron and stamped tin, and a fiery red steam pumper complete with two firemen. Made primarily of cast iron, the toys were manufactured between 1880 and 1925.

How to Order the First Day of Issue Postmark

Customers have 30 days to obtain the first day of issue postmark by mail. They may purchase new stamps at their local Post Office, by telephone at 800-STAMP-24, and at the Postal Store Web site at www.usps.com. They should affix the stamps to envelopes of their choice, address the envelopes (to themselves or others), and place them in a larger envelope addressed to:

ANTIQUÉ TOYS DEFINITIVE STAMP
 POSTMASTER
 SPECIAL CANCELLATIONS
 PO BOX 92282
 WASHINGTON DC 20090-2282

Issue:	<i>Antique Toys</i>
Item Number:	671400
Denomination & Type of Issue:	Nondenominated, Definitive
Format:	Folded Vending Booklet of 20 (4 designs)
Series:	N/A
Issue Date & City:	June 7, 2002, Washington, DC 20066
Photographer:	Sally Andersen-Bruce, New Milford, CT
Designer:	Derry Noyes, Washington, DC
Engraver:	Southern Graphic Systems
Art Director:	Derry Noyes, Washington, DC
Typographer:	Derry Noyes, Washington, DC
Modeler:	Avery Dennison, SPD
Manufacturing Process:	Gravure
Printer:	Avery Dennison, (AVR)
Printed at:	AVR, Clinton, SC
Press Type:	Dia Nippon Kiko (DNK)
Stamps per Booklet:	20
Print Quantity:	300 million stamps
Paper Type:	Pre-phosphored Type I, 175 PMU
Adhesive Type:	Pressure Sensitive
Processed at:	AVR, Clinton, SC
Colors:	Yellow, Cyan, Magenta, Black
Stamp Orientation:	Horizontal
Image Area (w x h):	0.818 x 0.720 in./20.777 x 18.288 mm
Overall Size (w x h):	0.982 x 0.870 in./24.943 x 22.098 mm
Full Booklet Size (w x h):	10.375 x 1.74 in./263.525 x 44.196 mm
Plate Size:	5 books across x 3 books around (24 per press sheet)
Plate Numbers:	"V" followed by four (4) single digits
Marginal Markings:	N/A
Catalog Item Number(s):	671440 Vending Booklet of 20 — \$7.40

After applying the first day of issue postmark, the Postal Service will return the envelopes through the mail. There is no charge for the postmark. All orders must be postmarked by July 8, 2002.

Stamp Fulfillment Services (SFS) also offers first day covers for new stamp issues and Postal Service stationery items postmarked with the official first day of issue cancellation. Each item has an individual catalog number and is offered in the quarterly *USA Philatelic* catalog.

Customers may request a free catalog by telephoning 800-STAMP-24 or writing to:

INFORMATION FULFILLMENT
DEPT 6270
US POSTAL SERVICE
PO BOX 219014
KANSAS CITY MO 64121-9014

First day covers remain on sale for at least 1 year after the stamp's issuance.

Philatelic Products

There are no philatelic products for this stamp issue.

Distribution: Items 671400 and 671411, PSA Folded Booklet of 20 (Vending Use Only)

Stamp distribution offices (SDOs) will receive an automatic distribution quantity of these vending books of 20. Distributions are rounded up to the nearest master carton size (4,500 books for straight; 3,000 books for criss-cross).

Initial Supply to Post Offices

SDOs *will not* make a subsequent automatic distribution to Post Offices. Only Post Offices equipped with the appropriate self-service vending machines may order these items from their designated SDO using a separate PS Form 17, *Stamp Requisition*. SDOs must not distribute books to Post Offices before May 28, 2002.

Additional Supply

Authorized Post Offices requiring additional books for restocking of the appropriate self-service vending machines must requisition them from their designated SDO using PS Form 17.

Additional quantities *will not* be available at accountable paper depositories (APDs) for supplemental ordering by SDOs.

Distribution: Item 671500, PSA Convertible Booklet of 20

SDOs will receive an approximate full distribution quantity for the *Antique Toys* nondenominated PSA booklet of 20. Distributions are rounded up to the nearest master carton size (4,000).

Initial Supply to Post Offices

SDOs will make a subsequent automatic distribution to Post Offices for their full standard automatic distribution quantities using PS Form 3309, *Advice of shipment, Stamp Invoice*, and PS Form 17, *Stamp Requisition*. SDOs must not distribute booklets to Post Offices before May 28, 2002.

Issue:	<i>Antique Toys</i>
Item Number:	671500
Denomination & Type of Issue:	Nondenominated, Definitive
Format:	Convertible Booklet of 20 (4 designs)
Series:	N/A
Issue Date & City:	June 7, 2002, Washington, DC 20066
Photographer:	Sally Andersen-Bruce, New Milford, CT
Designer:	Derry Noyes, Washington, DC
Engraver:	Southern Graphic Systems
Art Director:	Derry Noyes, Washington, DC
Typographer:	Derry Noyes, Washington, DC
Modeler:	Avery Dennison, SPD
Manufacturing Process:	Gravure
Printer:	Avery Dennison, (AVR)
Printed at:	AVR, Clinton, SC
Press Type:	Dia Nippon Kiko (DNK)
Stamps per Booklet:	20
Print Quantity:	1.2 billion stamps
Paper Type:	Pre-phosphored Type I, 175 PMU
Adhesive Type:	Pressure Sensitive
Processed at:	AVR, Clinton, SC
Colors:	Yellow, Cyan, Magenta, Black
Stamp Orientation:	Horizontal
Image Area (w x h):	0.818 x 0.720 in./20.777 x 18.288 mm
Overall Size (w x h):	0.982 x 0.870 in./24.943 x 22.098 mm
Full Booklet Size (w x h):	4.125 x 4.35 in./104.78 x 110.49 mm
Plate Size:	480 stamps per revolution
Plate Numbers:	"V" followed by four (4) single digits
Marginal Markings:	"© 2002 USPS" • Plate numbers • "Peel here to fold Self-adhesive stamps • DO NOT WET"
Catalog Item Number(s):	671540 Convertible Booklet of 20 — \$7.40 671563 First Day Cover — Set of 4 — \$3.00

Philatelic Requirement

SDOs will not receive a separate quantity of this definitive stamp for their authorized philatelic centers. Philatelic centers must be supplied their quantities from the initial automatic distribution made to SDOs.

Additional Supply

Post Offices requiring additional stamps must requisition them from their designated SDO using PS Form 17.

Additional quantities *will not* be available at APDs for supplemental ordering by SDOs.

— Stamp Services,
Government Relations and Public Policy, 5-16-02

STAMP ANNOUNCEMENT 02-14

Masters of American Photography Stamps

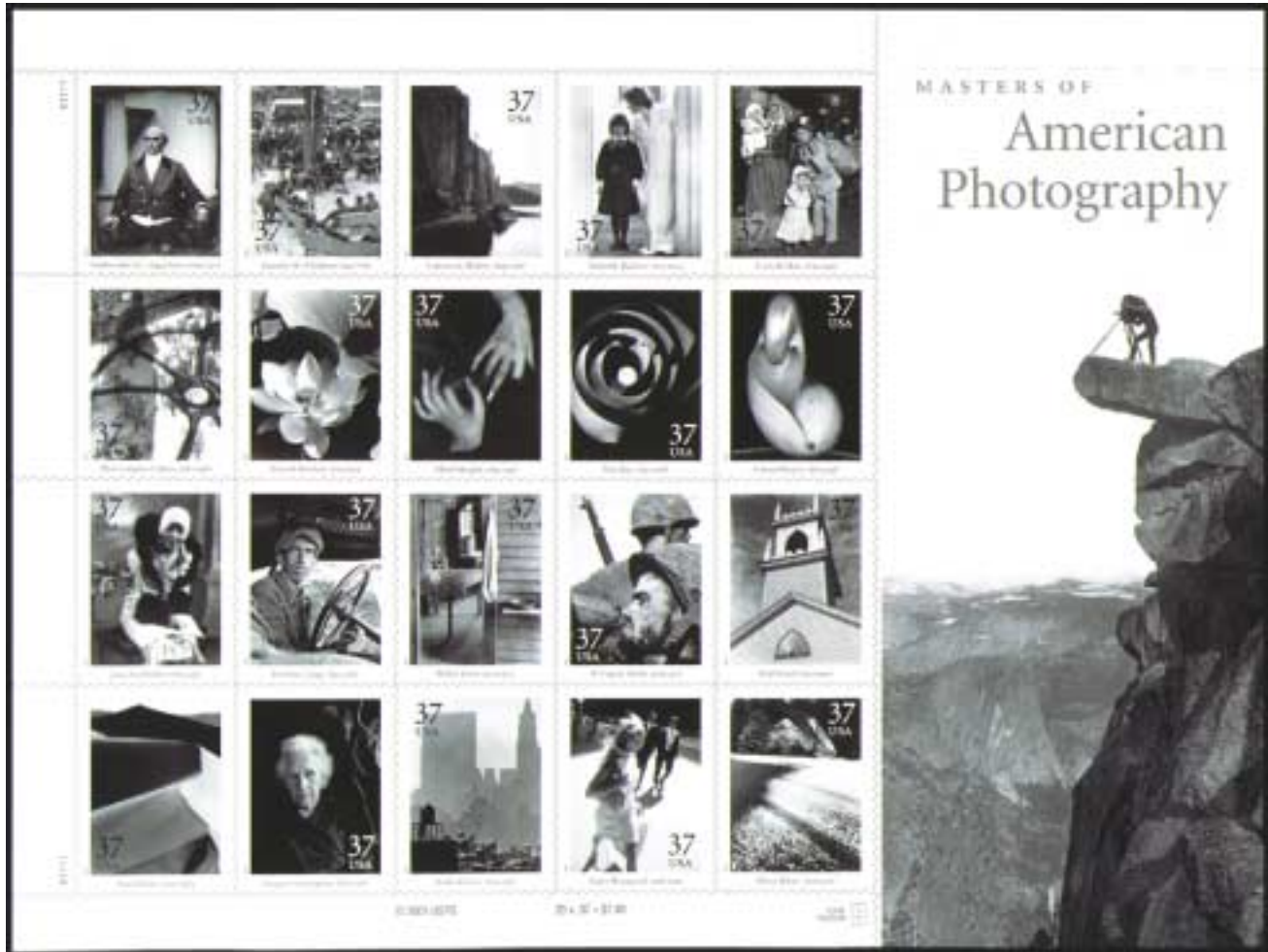

Copyright USPS 2001

The Postal Service will issue twenty 37-cent *Masters of American Photography* commemorative stamps (Item 562400) on June 13, 2002, in San Diego, California. The Classic Collection pane of 20 stamps designed by Derry Noyes, Washington, DC, goes on nationwide June 14, 2002. The stamps will be issued in a pressure-sensitive adhesive (PSA) pane of 20 with selvage and the pane may not be split and the stamps may not be sold individually.

The *Masters of American Photography* Classic Collection honors 20 of our country's most important and influential photographers and includes examples of portrait, documentary, landscape, and fine art photography. Many of the major themes and events in U.S. history, immigration, the Great Depression, and World War II, are captured in these compelling black-and-white stamp art images.

How to Order the First Day of Issue Postmark

Customers have 30 days to obtain the first day of issue postmark by mail. They may purchase new stamps at their local Post Office, by telephone at 800-STAMP-24, and at the Postal Store Web site at www.usps.com. They should affix the stamps to envelopes of their choice, address the envelopes (to themselves or others), and place them in a larger envelope addressed to:

MASTERS OF AMERICAN PHOTOGRAPHY
 POSTMASTER
 PO BOX 509505
 SAN DIEGO CA 92150-9505

After applying the first day of issue postmark, the Postal Service will return the envelopes through the mail. There is no charge for the postmark. All orders must be postmarked by July 13, 2002.

Stamp Fulfillment Services (SFS) also offers first day covers for new stamp issues and Postal Service stationery items postmarked with the official first day of issue cancellation. Each item has an individual catalog number and is offered in the quarterly *USA Philatelic* catalog. Customers may request a free catalog by telephoning 800-STAMP-24 or writing to:

INFORMATION FULFILLMENT
DEPT 6270
US POSTAL SERVICE
PO BOX 219014
KANSAS CITY MO 64121-9014

First day covers remain on sale for at least 1 year after the stamp's issuance.

Philatelic Products

There are no philatelic products for this stamp issue.

Distribution: Item 562400, Masters of American Photography, Classic Collection of 20, PSA

Stamp distribution offices (SDOs) will receive approximately one-half of their standard automatic distribution for a PSA sheet stamp. Distributions are rounded up to the nearest carton size (2,000 panes=40,000 stamps).

Initial Supply to Post Offices

SDOs will make a subsequent automatic distribution to Post Offices for one-half of their standard automatic distribution quantities using PS Form 3309, *Advice of Shipment/Stamp Invoice*, and PS Form 17, *Stamp Requisition*. SDOs must not distribute stamps to Post Offices before June 6, 2002.

Philatelic Requirement

SDOs *will not* receive a separate quantity of the *Masters of American Photography* pane for their authorized philatelic centers. Philatelic centers must be supplied needed quantities from the initial automatic distribution made to the SDO.

Additional Supply

Post Offices requiring additional stamps must requisition them from their designated SDO using PS Form 17.

The APDs *will not* have additional *Masters of American Photography* panes available for fulfilling supplemental ordering by SDOs.

Issue:	<i>Masters of American Photography</i>
Item Number:	562400
Denomination & Type of Issue:	37-cent Commemorative
Format:	Pane of 20 with selvage (20 designs)
Series:	Classic Collection
Issue Date & City:	June 13, 2002, San Diego, CA 92199
Designer:	Derry Noyes, Washington, DC
Art Director:	Derry Noyes, Washington, DC
Typographer:	Derry Noyes, Washington, DC
Photography:	Multiple photographers
Modeler:	Donald H. Woo
Manufacturing Process:	Gravure
Printer:	Sennett Security Products (SSP)
Printed at:	American Packaging Corporation, Columbus, WI
Press Type:	Rotomec, 3000
Engraver:	Arnotek Industries
Stamps per Pane:	20
Print Quantity:	60 million stamps
Paper Type:	Pre-phosphored, Type I
Adhesive Type:	Pressure Sensitive
Processed at:	Unique Binders, Fredericksburg, VA
Colors:	Black, Black, PMS 430
Stamp Orientation:	Vertical
Image Area (w x h):	1.075 x 1.40 in./27.31 x 35.56 mm
Overall Size (w x h):	1.225 x 1.55 in./31.12 x 39.37 mm
Pane Size (w x h):	9.563 x 7.125 in./242.90 x 180.98 mm
Plate Size:	120 stamps per revolution
Plate Numbers:	"S" followed by three (3) single digits
Marginal Markings:	"© 2001 USPS" • Price • Plate numbers in all four corners • Plate position diagram • Text on reverse side
Catalog Item Number(s):	562440 Full Pane of 20 w/plate no. — \$7.40 562462 First Day Cover — \$9.40 562484 Press Sheet — \$44.40

Sales Policy

All Post Offices must acquire and maintain a supply of each new commemorative stamp as long as customer demand exists, until inventory is depleted, or until the stamp is officially withdrawn from sale. If supplies run low, Post Offices must reorder additional quantities using their normal ordering procedures. **The *Masters of American Photography* Classic Collection may not be split and the stamps may not be sold individually.**

— Stamp Services,
Government Relations and Public Policy, 5-16-02

STAMP ANNOUNCEMENT 02-15

Ribbon Star Stamped Envelope

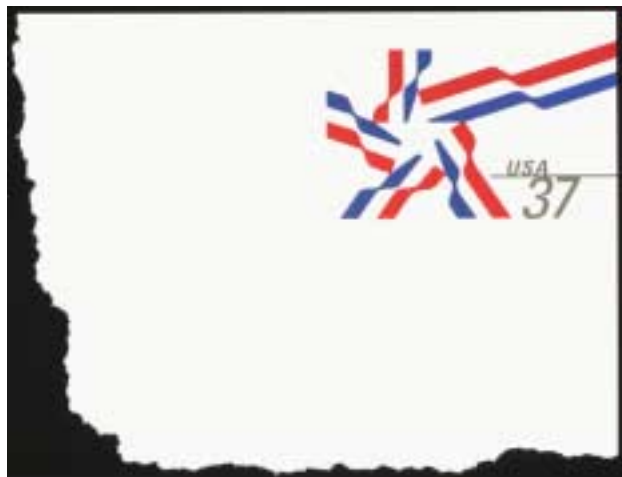

Copyright USPS 2002

The Postal Service will issue a 37-cent *Ribbon Star* stamped envelope on June 7, 2002, in Washington, DC. The envelope, designed by Terrence W. McCaffrey, U.S. Postal Service, Washington, DC, goes on sale nationwide June 7, 2002. The *Ribbon Star* envelope will be issued in a #10 regular envelope (Item 214100), #10 window envelope (Item 214200), 6-3/4 regular envelope (Item 264100), 6-3/4 window envelope (Item 264200), #9 security envelope (Item 214300), and a #9 security window envelope (Item 215400).

The *Ribbon Star* envelope features a patriotic star created from a red, white, and blue ribbon.

How to Order the First Day of Issue Postmark

Customers have 30 days to obtain the first day of issue postmark by mail. They may purchase new stamps at their local Post Office, by telephone at 800-STAMP-24, and at the Postal Store Web site at www.usps.com. They should address the envelopes of their choice (to themselves or others), and place them in a larger envelope addressed to:

RIBBON STAR STAMPED ENVELOPE
 POSTMASTER
 SPECIAL CANCELLATIONS
 PO BOX 92282
 WASHINGTON DC 20090-2282

After applying the first day of issue postmark, the Postal Service will return the envelopes through the mail. There is no charge for the postmark. All orders must be postmarked by July 8, 2002.

Issue:	<i>Ribbon Star</i>
Item Number:	214100
Denomination & Type of Issue:	37-cent Envelope
Format:	#10 Regular Envelope
Series:	N/A
Issue Date & City:	June 7, 2002, Washington, DC 20066
Designer:	Terrence W. McCaffrey, USPS, Washington, DC
Engraver:	N/A
Art Director:	Terrence W. McCaffrey, USPS, Washington, DC
Typographer:	Terrence W. McCaffrey, USPS, Washington, DC
Modeler:	N/A
Manufacturing Process:	Flexo, Phosphor Tagging
Printer:	MeadWestvaco
Printed at:	MeadWestvaco, Williamsburg, PA
Press Type:	VH-1
Stamps per Pane/Sheet:	N/A
Print Quantity:	55 million envelopes
Paper Type:	100% recycled paper, 30% post consumer
Adhesive Type:	Water-Activated
Processed at:	MeadWestvaco, Williamsburg, PA
Colors (PMS Colors):	PMS 186 (Red), PMS 286 (Blue), PMS 8 (Cool Gray)
Envelope Orientation:	Horizontal
Envelope Size (w x h):	9.50 x 4.125 in./241.30 x 104.77 mm
Image Size (w x h):	2 x 1.125 in./50.80 x 28.58 mm
Marginal Markings:	"© USPS 2002" • Recycle logo followed by "THIS ENVELOPE IS RECYCLABLE AND MADE WITH 100% RECYCLED PAPER, 30% POST-CONSUMER CONTENT"
Catalog Item Number(s)	214140 Single #10 Regular — \$0.45 214105 Packet of 5 — \$2.25 214180 Box of 500 — \$199.50 214161 First Day Cancellation — \$0.55

Stamp Fulfillment Services (SFS) also offers first day covers for new stamp issues and Postal Service stationery items postmarked with the official first day of issue cancellation. Each item has an individual catalog number and is offered in the quarterly *USA Philatelic* catalog. Customers may request a free catalog by telephoning 800-STAMP-24 or writing to:

INFORMATION FULFILLMENT
 DEPT 6270
 US POSTAL SERVICE
 PO BOX 219014
 KANSAS CITY MO 64121-9014

First day covers remain on sale for at least 1 year after the stamp's issuance.

Philatelic Products

There are no philatelic products for this stamped envelope issue.

Distribution: Ribbon Star Stamped Envelopes

Stamp distribution offices (SDOs) will receive an automatic distribution of the following *Ribbon Star* stamped envelope items: Item 224100, #10 regular; Item 224200, #10 window; Item 224300, #9 regular; Item 225400, #9 window; Item 264100, 6-3/4 regular; and, Item 264200, 6-3/4 window. Automatic distribution quantities will approximate the SDO's 60-day requirements for each item. Shipments began April 29, 2002, and will complete May 24, 2002. A second automatic distribution is scheduled *only* for Items 224100, #10 regular, and 264100, 6-3/4 regular. This second automatic distribution is scheduled to begin shipment June 17, 2002, will complete July 12, 2002, and will approximate an additional 30-day supply of both items.

Initial Supply to Post Offices

Post Offices *will not* receive an automatic distribution of these stamped envelopes, but should order sufficient quantities of Items 224100, 224200, 224300, 225400, 264100, or 264200 to meet the anticipated needs of mailers, and local philatelic demand. Post Offices must order these stamped envelopes from their designated SDO using a separate PS Form 17. SDOs must not distribute the stamped envelopes to Post Offices before May 28, 2002.

Philatelic Requirement

SDOs *will not* receive a separate quantity of these stamped envelopes for their authorized philatelic centers. Philatelic centers must be supplied needed quantities from the initial automatic distribution made to the SDO.

Additional Supply

Post Offices requiring additional stamped envelopes must requisition them from their designated SDO using PS Form 17.

SDOs requiring additional quantities of stamped envelope Items 224100, 224200, 224300, 225400, 264100 or 264200 must submit PS Form 3205, *Requisition for Plain Stamped Envelopes*, to Stamp Fulfillment Services (SFS).

Issue:	<i>Ribbon Star</i>
Item Number:	214200
Denomination & Type of Issue:	37-cent Envelope
Format:	# 10 Window Envelope
Series:	N/A
Issue Date & City:	June 7, 2002, Washington, DC 20066
Designer:	Terrence W. McCaffrey, USPS, Washington, DC
Engraver:	N/A
Art Director:	Terrence W. McCaffrey, USPS, Washington, DC
Typographer:	Terrence W. McCaffrey, USPS, Washington, DC
Modeler:	N/A
Manufacturing Process:	Flexo, Phosphor Tagging
Printer:	MeadWestvaco
Printed at:	MeadWestvaco, Williamsburg, PA
Press Type:	VH-1
Stamps per Pane/Sheet:	N/A
Print Quantity:	13 million envelopes
Paper Type:	100% recycled paper, 30% post consumer
Adhesive Type:	Water-Activated
Processed at:	MeadWestvaco, Williamsburg, PA
Colors (PMS Colors):	PMS 186 (Red), PMS 286 (Blue), PMS 8 (Cool Gray)
Envelope Orientation:	Horizontal
Envelope Size (w x h):	9.50 x 4.125 in./241.30 x 104.77 mm
Image Size (w x h):	2 x 1.125 in./50.80 x 28.58 mm
Marginal Markings:	"© USPS 2002" • Recycle logo followed by "THIS ENVELOPE IS RECYCLABLE AND MADE WITH 100% RECYCLED PAPER, 30% POST-CONSUMER CONTENT"
Catalog Item Number(s)	214240 #10 Window — \$0.45 214205 Packet of 5 — \$2.25 214280 Box of 500 — \$199.00 214261 Cancelled Envelope — \$0.55

Issue:	<i>Ribbon Star</i>
Item Number:	264100
Denomination & Type of Issue:	37-cent Envelope
Format:	6-3/4 Regular Envelope
Series:	N/A
Issue Date & City:	June 7, 2002, Washington, DC 20066
Designer:	Terrence W. McCaffrey, USPS, Washington, DC
Engraver:	N/A
Art Director:	Terrence W. McCaffrey, USPS, Washington, DC
Typographer:	Terrence W. McCaffrey, USPS, Washington, DC
Modeler:	N/A
Manufacturing Process:	Flexo, Phosphor Tagging
Printer:	MeadWestvaco
Printed at:	MeadWestvaco, Williamsburg, PA
Press Type:	VH-1
Stamps per Pane/Sheet:	N/A
Print Quantity:	17 million envelopes
Paper Type:	100% recycled paper, 30% post consumer
Adhesive Type:	Water-Activated
Processed at:	MeadWestvaco, Williamsburg, PA
Colors (PMS Colors):	PMS 186 (Red), PMS 286 (Blue), PMS 8 (Cool Gray)
Envelope Orientation:	Horizontal
Envelope Size (w x h):	6.50 x 3.625in./165.10 x 92.08 mm
Image Size (w x h):	2 x 1.125 in./50.80 x 28.58 mm
Marginal Markings:	“© USPS 2002” • Recycle logo followed by “ <i>THIS ENVELOPE IS RECYCLABLE AND MADE WITH 100% RECYCLED PAPER, 30% POST-CONSUMER CONTENT</i> ”
Catalog Item Number(s)	264140 #6 ¾ Regular — \$0.45 264105 Packet of 5 — \$2.25 264180 Box of 500 — \$197.00 264161 Cancelled Envelope — \$0.55

Issue:	<i>Ribbon Star</i>
Item Number:	264200
Denomination & Type of Issue:	37-cent Envelope
Format:	6-3/4 Window Envelope
Series:	N/A
Issue Date & City:	June 7, 2002, Washington, DC 20066
Designer:	Terrence W. McCaffrey, USPS, Washington, DC
Engraver:	N/A
Art Director:	Terrence W. McCaffrey, USPS, Washington, DC
Typographer:	Terrence W. McCaffrey, USPS, Washington, DC
Modeler:	N/A
Manufacturing Process:	Flexo, Phosphor Tagging
Printer:	MeadWestvaco
Printed at:	MeadWestvaco, Williamsburg, PA
Press Type:	VH-1
Stamps per Pane/Sheet:	N/A
Print Quantity:	5 million envelopes
Paper Type:	100% recycled paper, 30% post consumer
Adhesive Type:	Water-Activated
Processed at:	MeadWestvaco, Williamsburg, PA
Colors (PMS Colors):	PMS 186 (Red), PMS 286 (Blue), PMS 8 (Cool Grey)
Envelope Orientation:	Horizontal
Envelope Size (w x h):	6.50 x 3.625in./165.10 x 92.08 mm
Image Size (w x h):	2 x 1.125 in./50.80 x 28.58 mm
Marginal Markings:	“© USPS 2002” • Recycle logo followed by “ <i>THIS ENVELOPE IS RECYCLABLE AND MADE WITH 100% RECYCLED PAPER, 30% POST-CONSUMER CONTENT</i> ”
Catalog Item Number(s)	264240 #6 ¾ Window — \$0.45 264205 Packet of 5 — \$2.25 264280 Box of 500 — \$197.00 264261 Cancelled Envelope — \$0.55

Issue:	<i>Ribbon Star</i>
Item Number:	214300
Denomination & Type of Issue:	37-cent Envelope
Format:	#9 Security Envelope
Series:	N/A
Issue Date & City:	June 7, 2002, Washington, DC 20066
Designer:	Terrence W. McCaffrey, USPS, Washington, DC
Engraver:	N/A
Art Director:	Terrence W. McCaffrey, USPS, Washington, DC
Typographer:	Terrence W. McCaffrey, USPS, Washington, DC
Modeler:	N/A
Manufacturing Process:	Flexo, Phosphor Tagging
Printer:	MeadWestvaco
Printed at:	MeadWestvaco, Williamsburg, PA
Press Type:	VH-1
Stamps per Pane/Sheet:	N/A
Print Quantity:	1.2 million envelopes
Paper Type:	100% recycled paper, 30% post consumer
Adhesive Type:	Water-Activated
Processed at:	MeadWestvaco, Williamsburg, PA
Colors (PMS Colors):	PMS 186 (Red), PMS 286 (Blue), PMS 8 (Cool Gray)
Envelope Orientation:	Horizontal
Envelope Size (w x h):	8.875 x 3.875in./225.42 x 98.42 mm
Image Size (w x h):	2 x 1.125 in./50.80 x 28.58 mm
Marginal Markings:	“© USPS 2002” • Recycle logo followed by “ <i>THIS ENVELOPE IS RECYCLABLE AND MADE WITH 100% RECYCLED PAPER, 30% POST-CONSUMER CONTENT</i> ”
Catalog Item Number(s)	214340 #9 Regular— \$0.45 214305 Packet of 5 — \$2.25 214380 Box of 500 — \$199.00 214361 Cancelled Envelope — \$0.55

Issue:	<i>Ribbon Star</i>
Item Number:	215400
Denomination & Type of Issue:	37-cent Envelope
Format:	#9 Security Window Envelope
Series:	N/A
Issue Date & City:	June 7, 2002, Washington, DC 20066
Designer:	Terrence W. McCaffrey, USPS, Washington, DC
Engraver:	N/A
Art Director:	Terrence W. McCaffrey, USPS, Washington, DC
Typographer:	Terrence W. McCaffrey, USPS, Washington, DC
Modeler:	N/A
Manufacturing Process:	Flexo, Phosphor Tagging
Printer:	MeadWestvaco
Printed at:	MeadWestvaco, Williamsburg, PA
Press Type:	VH-1
Stamps per Pane/Sheet:	N/A
Print Quantity:	1 million envelopes
Paper Type:	100% recycled paper, 30% post consumer
Adhesive Type:	Water-Activated
Processed at:	MeadWestvaco, Williamsburg, PA
Colors (PMS Colors):	PMS 186 (Red), PMS 286 (Blue), PMS 8 (Cool Gray)
Envelope Orientation:	Horizontal
Envelope Size (w x h):	8.875 x 3.875in./225.42 x 98.42 mm
Image Size (w x h):	2 x 1.125 in./50.80 x 28.58 mm
Marginal Markings:	“© USPS 2002” • Recycle logo followed by “ <i>THIS ENVELOPE IS RECYCLABLE AND MADE WITH 100% RECYCLED PAPER, 30% POST-CONSUMER CONTENT</i> ”
Catalog Item Number(s)	205440 #9 Security Window — \$0.45 205405 Packet of 5 — \$2.25 205480 Box of 500 — \$199.00 205461 Cancelled Envelope — \$0.55

— Stamp Services,
Government Relations and Public Policy, 5-16-02

STAMP ANNOUNCEMENT 02-16

Carlsbad Caverns National Park Stamped Card

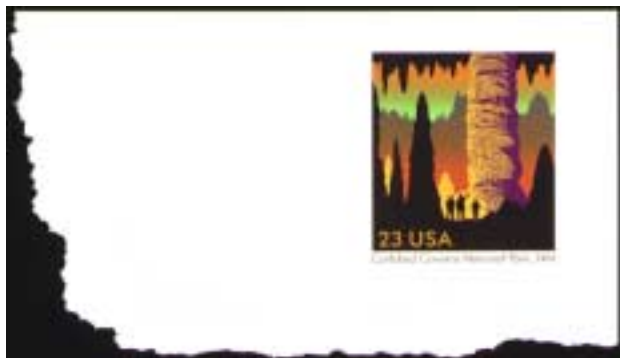

Copyright USPS 2002

The Postal Service will issue 23-cent *Carlsbad Caverns National Park* single-cut stamped card (Item 221100) on June 7, 2002, in Carlsbad, New Mexico. The card, designed by Carl Herrman, Carlsbad, California, and illustrated by Tom Engeman, Brunswick, Maryland, goes on sale nationwide June 7, 2002. The stamped card will also be produced in double-cut reply cards (Item 221200); sheet of 40 cards (Item 221300); and 5-card banded (Item 222000).

More than 1,000 years ago prehistoric Native Americans ventured into Carlsbad Cavern in New Mexico seeking shelter. Much later, in the 1800s, settlers discovered the cavern, drawn to it by the spectacle of hundreds of thousands of bats rising up out of the natural entrance in the evening. The natural wonders of this extraordinary place eventually spread to Washington, DC. In 1923, the U.S. Interior Department sent inspectors to investigate the cavern and determine whether it was truly an outstanding natural scenic wonder. Later that year, Carlsbad Cavern was proclaimed a national monument. On December 6, 1995, the cavern was designated a World Heritage Site. Finds in recent years include the Guadalupe Room in 1966, which is the second largest room in the cavern, the exceptionally colorful and much decorated Bifrost Room in 1982, and the Chocolate High in 1993. Research is slowly answering many questions about the complex creation of the cavern, the unfamiliar world of bats and other members of the cave community, and the effects of man's activities on the cave.

How to Order the First Day of Issue Postmark

Customers have 30 days to obtain the first day of issue postmark by mail. They may purchase new cards at their local Post Office, by telephone at 800-STAMP-24, and at the Postal Store Web site at www.usps.com. They should

address the cards (to themselves or others) and place them in a large envelope addressed to:

CARLSBAD CAVERNS NATIONAL PARK STAMPED CARD
 POSTMASTER
 301 N CANYON ST
 CARLSBAD NM 88220-9998

Issue:	<i>Carlsbad Caverns</i>
Item Number:	221100
Denomination & Type of Issue:	23-cent Stamped Card
Format:	Single Cut Cards
Series:	N/A
Issue Date & City:	June 7, 2002, Carlsbad, NM 88220
Illustrator:	Tom Engeman, Brunswick, MD
Designer:	Carl Herrman, Carlsbad, CA
Art Director:	Carl Herrman, Carlsbad, CA
Typographer:	Carl Herrman, Carlsbad, CA
Modeler:	N/A
Manufacturing Process:	Offset
Printer:	Government Printing Office (GPO)
Printed at:	GPO, Washington, DC
Press Type:	Offset
Print Quantity:	70 million stamped cards
Paper Type:	22-lb. bright white
Adhesive Type:	N/A
Processed at:	GPO, Washington, DC
Colors:	Yellow, Magenta, Cyan, Black
Image Orientation:	Vertical
Image Area (w x h):	1.25 x 1.40 in./31.78 x 35.56 mm
Card Size (w x h):	5.5 x 3.5 in./139.50 x 88.83 mm
Full Pane Size (w x h):	N/A
Plate Size:	N/A
Plate Numbers:	N/A
Marginal Markings:	"© USPS 2002" • Recycled logo followed by "recycled"
Catalog Item Number(s):	221140 Single Stamped Card — \$0.25 221161 First Day Cover — \$0.35

After applying the first day of issue postmark, the Postal Service will return the cards through the mail. There is no charge for the postmark. All orders must be postmarked by July 8, 2002.

Stamp Fulfillment Services (SFS) also offers first day covers for new stamp issues and Postal Service stationery items postmarked with the official first day of issue cancellation. Each item has an individual catalog number and is offered in the quarterly *USA Philatelic* catalog. Customers may request a free catalog by telephoning 800-STAMP-24 or writing to:

INFORMATION FULFILLMENT
 DEPT 6270
 US POSTAL SERVICE
 PO BOX 219014
 KANSAS CITY MO 64121-9014

First day covers remain on sale for at least 1 year after the stamped card's issuance.

Philatelic Products

There are no philatelic products for this stamp issue.

Distribution: Carlsbad Caverns National Park Stamped Cards

Stamp distribution offices (SDOs) will receive an automatic distribution of the following *Carlsbad Caverns National Park* stamped cards: Item 221100, Single-Cut Card; Item 221200, Double-Cut Reply Card; Item 221300, Sheet Cards; and Item 222000, Banded Cards (for vending use only). Automatic distribution quantities will approximate the SDO's 90-day requirements for each item. Stamped card items will be distributed in two waves with each wave approximating a 45-day supply. Wave one shipments began May 1, 2002, and will complete May 23, 2002. Wave two is scheduled to begin May 28, 2002, and will complete June 17, 2002.

Initial Supply to Post Offices

Post Offices *will not* receive an automatic distribution of these stamped cards, but should order sufficient quantities of items 221100, 221200, 221300, or 222000 to meet the anticipated needs of mailers, and local philatelic demand. Post Offices must order these stamped cards from their designated SDO using a separate PS Form 17. SDOs must not distribute the stamped cards to Post Offices before May 28, 2002.

Philatelic Requirement

SDOs will not receive a separate quantity of these stamped cards for their authorized philatelic centers. Philatelic centers must be supplied needed quantities from the initial automatic distribution made to the SDO.

Additional Supply

Post Offices requiring additional stamped cards must requisition them from their designated SDO using PS Form 17.

SDOs requiring additional quantities of stamped card items 221100, 221200, 221300, or 222000 must submit a PS Form 3216, *Requisition for Postal Cards — Bulk Quantities*, to the Government Printing Office (GPO).

Issue:	<i>Carlsbad Caverns</i>
Item Number:	221200
Denomination & Type of Issue:	23-cent Stamped Card
Format:	Double Cut Reply Cards
Series:	N/A
Issue Date & City:	June 7, 2002, Carlsbad, NM 88220
Illustrator:	Tom Engeman, Brunswick, MD
Designer:	Carl Herrman, Carlsbad, CA
Art Director:	Carl Herrman, Carlsbad, CA
Typographer:	Carl Herrman, Carlsbad, CA
Modeler:	N/A
Manufacturing Process:	Offset
Printer:	Government Printing Office (GPO)
Printed at:	GPO, Washington, DC
Press Type:	Offset
Print Quantity:	4 million stamped cards
Paper Type:	22-lb. bright white
Adhesive Type:	N/A
Processed at:	GPO, Washington, DC
Colors:	Yellow, Magenta, Cyan, Black
Image Orientation:	Vertical
Image Area (w x h):	1.25 x 1.40 in./31.78 x 35.56 mm
Card Size (w x h):	5.5 x 3.5 in./139.70 x 88.90 mm
Full Pane Size (w x h):	N/A
Plate Size:	N/A
Plate Numbers:	N/A
Marginal Markings:	"© USPS 2002" • Recycled logo followed by "recycled"
Catalog Item Number(s):	221240 Single Stamped Reply Card — \$0.50 221261 First Day Cover — \$0.60

Issue:	<i>Carlsbad Caverns</i>
Item Number:	221300
Denomination & Type of Issue:	23-cent Stamped Card
Format:	Sheet of 40 Cards
Series:	N/A
Issue Date & City:	June 7, 2002, Carlsbad, NM 88220
Illustrator:	Tom Engeman, Brunswick, MD
Designer:	Carl Herrman, Carlsbad, CA
Art Director:	Carl Herrman, Carlsbad, CA
Typographer:	Carl Herrman, Carlsbad, CA
Modeler:	N/A
Manufacturing Process:	Offset
Printer:	Government Printing Office (GPO)
Printed at:	GPO, Washington, DC
Press Type:	Offset
Print Quantity:	20 million stamped cards
Paper Type:	22-lb. bright white
Adhesive Type:	N/A
Processed at:	GPO, Washington, DC
Colors:	Yellow, Magenta, Cyan, Black
Image Orientation:	Vertical
Image Area (w x h):	1.25x 1.40 in./31.78 x 35.56 mm
Card Size (w x h):	5.5 x 3.5 in./139.70 x 88.90 mm
Full Pane Size (w x h):	N/A
Plate Size:	N/A
Plate Numbers:	N/A
Marginal Markings:	"© USPS 2002" • Recycled logo followed by "recycled"
Catalog Item Number(s):	N/A

Issue:	<i>Carlsbad Caverns</i>
Item Number:	222000
Denomination & Type of Issue:	23-cent Stamped Card
Format:	Banded Cards
Series:	N/A
Issue Date & City:	June 7, 2002, Carlsbad, NM 88220
Illustrator:	Tom Engeman, Brunswick, MD
Designer:	Carl Herrman, Carlsbad, CA
Art Director:	Carl Herrman, Carlsbad, CA
Typographer:	Carl Herrman, Carlsbad, CA
Modeler:	N/A
Manufacturing Process:	Offset
Printer:	Government Printing Office (GPO)
Printed at:	GPO, Washington, DC
Press Type:	Offset
Print Quantity:	4 million stamped cards
Paper Type:	22-lb. bright white
Adhesive Type:	N/A
Processed at:	GPO, Washington, DC
Colors:	Yellow, Magenta, Cyan, Black
Image Orientation:	Vertical
Image Area (w x h):	1.25 x 1.40 in./31.78 x 3.56 mm
Card Size (w x h):	5.5 x 3.5 in./139.70 x 88.90 mm
Full Pane Size (w x h):	N/A
Plate Size:	N/A
Plate Numbers:	N/A
Marginal Markings:	"© USPS 2002" • Recycled logo followed by "recycled"
Catalog Item Number(s):	N/A

— Stamp Services,
Government Relations and Public Policy, 5-16-02

STAMP ANNOUNCEMENT 02-17

Heroes of 2001 Semipostal Stamp

Copyright USPS 2002

The Postal Service will issue a nondenominated (45-cent value) *Heroes of 2001* semipostal, pressure-sensitive adhesive (PSA) pane of 20 stamps (Item 566000) on June 7, 2002, in New York, New York. The stamp, designed by Derry Noyes, Washington, DC, and photographed by Thomas E. Franklin, Bergen County, New Jersey, will be available for sale nationwide on June 7, 2002.

In honor of the American heroes who responded to the terrorist attacks of September 11, 2001, the *Heroes of 2001* semipostal stamps offers the public a way to provide assistance to the families of emergency relief personnel who died or were permanently disabled in the line of duty. The stamp is valid for postage at the First-Class Mail® rate, plus an 8-cent surcharge. The net proceeds from the surcharge will be transferred to the Federal Emergency Management Agency in accordance with the provisions of the 9/11 Heroes Stamp Act of 2001.

Issue:	<i>Heroes of 2001</i>
Item Number:	566000
Denomination & Type of Issue:	45-Cent First-Class Mail Rate Semipostal
Format:	Pane of 20 (1 design)
Series:	N/A
Issue Date & City:	May 29, 2002, New York, NY 10199
Designer:	Derry Noyes, Washington, DC
Photographer:	Thomas E. Franklin, Bergen County, NJ
Engraver:	N/A
Art Director:	Derry Noyes, Washington, DC
Modeler:	Joseph Sheeran
Manufacturing Process:	Offset
Printer:	Ashton Potter (USA) Ltd. (APU)
Printed at:	Williamsville, NY
Press Type:	Stevens, Security Press
Stamps per Pane:	20
Print Quantity:	205 million stamps
Paper Type:	Nonphosphored, Type III
Gum Type:	Self-adhesive
Processed at:	Ashton Potter (USA) Ltd.
Colors:	Black, Cyan, Magenta, Yellow
Stamp Orientation:	Vertical
Image Area (w x h):	1.44 x 1.105 in./36.576 x 28.067 mm
Overall Size (w x h):	1.56 x 1.225 in./39.624 x 31.115 mm
Pane Size (w x h):	7.26 x 7.13 in./184.40 x 181.102 mm
Plate Size:	120 stamps per revolution
Plate Numbers:	"P" followed by four (4) single digits
Marginal Markings:	"© 2002 USPS" • Plate lock (6 positions) • Plate numbers • Barcodes #566000 • Header "America Responds 20 stamps that help make a difference" • Bottom selvage text "The 9/11 Heroes Stamp Act of 2001 directs the Postal Service to transfer the net proceeds from the sale of these stamps to the Federal Emergency Management Agency to provide assistance to the families of emergency relief personnel who died or were permanently disabled in the line of duty in connection with the terrorist attacks of September 11, 2001. Each "Heroes" stamp is valid postage at the First Class, first-ounce rate in effect at the time of purchase." • Photo credit line "Photo © 2001 <i>The Record</i> (Bergen County, N.J.), Thomas E. Franklin, staff photographer."
Catalog Item Number(s):	566040 Full Pane of 20 w/plate no. — \$9.00 566030 Block of 10 — \$4.50 566020 Block of 4 — \$1.80 566061 First Day Cancellation — \$0.75

How to Order the First Day of Issue Postmark

Customers have 30 days to obtain the first day of issue postmark by mail. They may purchase new stamps at their local Post Office, by telephone at 800-STAMP-24, and at the Postal Store Web site at *www.usps.com*. They should affix the stamps to envelopes of their choice, address the envelopes (to themselves or others), and place them in a larger envelope addressed to:

HEROES OF 2001 SEMIPOSTAL
 POSTMASTER
 421 EIGHTH AVE RM 3006
 NEW YORK NY 10199-9991

After applying the first day of issue postmark, the Postal Service will return the envelopes through the mail. There is no charge for the postmark. All orders must be postmarked by July 8, 2002.

Stamp Fulfillment Services (SFS) also offers first day covers for new stamp issues and Postal Service stationery items postmarked with the official first day of issue cancellation. Each item has an individual catalog number and is offered in the quarterly *USA Philatelic* catalog. Customers may request a free catalog by telephoning 800-STAMP-24 or writing to:

INFORMATION FULFILLMENT
 DEPT 6270
 US POSTAL SERVICE
 PO BOX 219014
 KANSAS CITY MO 64121-9014

First day covers remain on sale for at least 1 year after the stamp's issuance.

Philatelic Products

There are no philatelic products for this stamp issue.

Distribution: Items 566000, Heroes of 2001 Semipostal PSA Pane of 20 Stamps

Stamp distribution offices (SDOs) and stamp service centers (SSCs) will receive two waves of three-fourths of their standard distribution in each wave of item 566000. Wave 1 shipments began March 19, 2002, and completed April 9, 2002. Wave 2 shipments began April 16, 2002, and completed May 9, 2002.

Initial Supply to Post Offices

SDOs and SSCs will make a subsequent automatic distribution to Post Offices for their full standard distribution, using PS Form 3309, *Advice of Shipment/Stamp Invoice*, and PS Form 17, *Stamp Requisition*. SDOs and SSCs must not distribute stamps to Post Offices before May 28, 2002.

Philatelic Requirement

SDOs with authorized philatelic centers will receive an automatic distribution of these stamps in six positions for subsequent distribution to each philatelic window.

SDOs That Serve This Many Philatelic Windows...	Will Receive This Quantity of the Nondenominated Heroes of 2001 Semipostal Stamp, Item 566000...
1	12,000
2	24,000
3	36,000
4	48,000
5	60,000
6	72,000
7	84,000
8	96,000
9	108,000
12	144,000
13	156,000
16	192,000
19	228,000

Additional Supply

Post Offices requiring additional stamps must requisition them from their designated SDO or SSC, using a separate PS Form 17.

The San Francisco, Chicago, and Memphis APDs will receive 4,000,000 additional stamps; the Denver APD will receive 2,000,000 additional stamps; and the New York APD will receive 6,000,000 additional stamps. For fulfilling supplemental orders, the Kansas City SSC will receive 5,000,000 additional stamps.

Sales Policy

All Post Offices must acquire and maintain a supply of these stamps as long as customer demand exists or until the stamp is officially withdrawn from sale. If supplies run low, Post Offices must reorder additional quantities through their normal order procedures. All sales of the *Heroes of 2001* semipostal must be tracked in **AIC 087**. There will be no exceptions to this policy.

— Stamp Services,
 Government Relations and Public Policy, 5-16-02

REVISION

2002 Stamps and Postal Stationery — Announcement 02-C (May 2002)

The *2002 Stamps and Postal Stationery* announcement in *Postal Bulletin 22075* (5-2-02, pages 107–108) has been revised to reflect changes for the denominated 37-cent *U.S. Flag*, 37-cent *Women in Journalism*, 37-cent *Irving Berlin*, and 45-cent *Heroes of 2001* semipostal stamp issues. The revised announcement appears on pages 115-116.

— *Stamp Services,
Government Relations and Public Policy, 5-16-02*



2002 STAMPS AND POSTAL STATIONERY

This schedule is subject to change.

Revised Announcement 02-C (May 2002)

This is a periodic announcement of new stamps and postal stationery items being issued during the calendar year. For additional information on stamps and stamp products visit our Postal Store Web site at www.usps.com.

NOTE	ISSUE	FIRST DAY OF ISSUE	FIRST DAY CITY/STATE	FORMAT	DEADLINE
P	34¢ Winter Sports	Jan 8	Park City, UT 84060	PSA pane of 20 with header, 4 designs	Feb 7
	34¢ Mentoring a Child	Jan 10	Annapolis, MD 21401	PSA pane of 20 with selvage	Feb 9
	34¢ Langston Hughes (Black Heritage)	Feb 1	New York, NY 10199	PSA pane of 20	Mar 4
	34¢ Happy Birthday	Feb 8	Riverside, CA 92507	PSA pane of 20	Mar 11
	34¢ Year of the Horse (Lunar New Year)	Feb 11	New York, NY 10199	PSA pane of 20	Mar 13
	34¢ U.S. Military Academy (Bicentennial)	Mar 16	West Point, NY 10996	PSA pane of 20	Apr 15
P	34¢ Greetings from America	Apr 4 (nationwide)	New York, NY 10199 (simultaneously issued in all 50 state capitals and New York City)	PSA pane of 50, special issue, 50 designs	Jun 3
	34¢ Longleaf Pine Forest (Nature of America)	Apr 26	Tallahassee, FL 32301	PSA souvenir sheet of 10, 10 designs	May 28
+	5¢ American Toleware (American Design)	May 31	McLean, VA 22101 (NAPEX Show)	Gummed coil of 10,000	Jul 1
C	45¢ Heroes of 2001 (Semipostal)	June 7 (nationwide)	New York, NY 10199	PSA pane of 20 with selvage	Jul 8
N	U.S. Flag (non-denominated, 37¢ First-Class, 1 oz.)	Jun 7 (nationwide)	Washington, DC 20066 (no ceremony)	PSA pane of 20; PSA convertible booklet of 20; PSA doublesided book of 20; PSA vending book of 20; PSA ATM sheetlet of 18; gummed pane of 100; PSA coil of 100	Jul 8
N	37¢ U.S. Flag	Jun 7 (nationwide)	Washington, DC 20066 (no ceremony)	PSA pane of 20*; PSA convertible booklets of 10* and 20*; PSA doublesided book of 20*; PSA vending book of 20*; PSA coils of 100*, 3,000*, and 10,000; gummed coils of 100*, 3,000, and 10,000* *available at a later date	Sep 5
N	Antique Toys (non-denominated, 37¢ First-Class, 1 oz.)	Jun 7 (nationwide)	Washington, DC 20066 (no ceremony)	PSA convertible booklet of 20; PSA vending book of 20, 4 designs	Jul 8
N	37¢ Ribbon Star Stamped Envelope	Jun 7 (nationwide)	Washington, DC 20066 (no ceremony)	Stamped envelopes — #6 3/4, #9, and #10	Jul 8
N	3¢ Star (make-up rate)	Jun 7 (nationwide)	Washington, DC 20066 (no ceremony)	PSA pane of 50; gummed coil of 10,000* *available at a later date	Jul 8
N	23¢ Carlsbad Caverns Stamped Card	Jun 7	Carlsbad, NM 88220	Stamped card; reply card	Jul 8
C	37¢ Masters of American Photography (Classic Collection)	Jun 13	San Diego, CA 92199	PSA pane of 20 with selvage, 20 designs	Jul 13
	37¢ John James Audubon (American Treasures)	Jun 27	Santa Clara, CA 95050	PSA pane of 20 with header	Jul 27
	37¢ Harry Houdini	Jul 3	New York, NY 10199	PSA pane of 20	Aug 2

NOTE	ISSUE	FIRST DAY OF ISSUE	FIRST DAY CITY/STATE	FORMAT	DEADLINE
N	60¢ Coverlet Eagle (2 oz.)	Jul 12	Oak Brook, IL 60523 (Americover Show)	PSA pane of 20	Aug 12
N	37¢ Antique Toys	Jul 22	Rochester, NY 14692	PSA convertible booklet of 20; PSA vending book of 20; PSA coil of 100, 4 designs	Aug 21
N	3.85 Jefferson Memorial (Priority Mail)	Jul (late)	Washington, DC 20066	PSA pane of 20	TBD
N	\$13.65 U.S. Capitol at Dusk (Express Mail)	Jul (late)	Washington, DC 20066	PSA pane of 20	TBD
N	83¢ Edna Ferber (3 oz.)	Jul (late)	Appleton, WI 54911	PSA pane of 20	TBD
	37¢ Andy Warhol	Aug 9	Pittsburgh, PA 15290	PSA pane of 20 with selvage	Sep 9
	37¢ Teddy Bears	Aug 15	Atlantic City, NJ 08401 (American Philatelic Society Stamp Show)	PSA pane of 20 with header, 4 designs	Sep 14
N	37¢ Love (1 oz.)	Aug 16	Atlantic City, NJ 08401 (American Philatelic Society Stamp Show)	PSA convertible booklet of 20	Sep 16
N	60¢ Love (2 oz.)	Aug 16	Atlantic City, NJ 08401 (American Philatelic Society Stamp Show)	PSA pane of 20	Sep 16
	37¢ Ogden Nash	Aug 19	Baltimore, MD 21229	PSA pane of 20	Sep 18
	37¢ Duke Kahanamoku	Aug 24	Honolulu, HI 96820	PSA pane of 20	Sep 23
	37¢ American Bats	Sep 13	Austin, TX 78710	PSA pane of 20 with header, 4 designs	Oct 14
C	37¢ Women in Journalism	Sep 14	Fort Worth, TX 76161	PSA pane of 20 with header, 4 designs	Oct 14
C	37¢ Neuter or Spay	Sep 20 (nationwide)	Denver, CO 80202	PSA pane of 20 with header, 2 designs	Oct 21
C	37¢ Cary Grant (Legends of Hollywood)	Sep/Oct	TBD	PSA pane of 20 with selvage	TBD
	37¢ Hawaiian Missionaries	Oct 24	New York, NY 10199 (American Stamp Dealers Association Stamp Show)	Gummed souvenir sheet of 4, 4 designs	Nov 23
	37¢ Holiday: Snowmen	Oct (mid)	TBD	PSA pane of 20; PSA vending booklet of 20; PSA doublesided book of 20; PSA linerless coil of 100, 4 designs	TBD
	37¢ Christmas: Gossaert	Oct (mid)	Chicago, IL 60607	PSA convertible booklet of 20	TBD
N	37¢ Kwanzaa (re-issue, new rate)	TBD	Washington, DC 20066 (no ceremony)	PSA pane of 20	TBD
N	37¢ Hanukkah (re-issue, new rate)	TBD	Washington, DC 20066 (no ceremony)	PSA pane of 20	TBD
N	37¢ Eid (re-issue, new rate)	TBD	Washington, DC 20066 (no ceremony)	PSA pane of 20	TBD
N	37¢ Official Mail	TBD	Washington, DC 20066 (no ceremony)	Gummed coil of 100; #10 stamped envelope	TBD
	37¢ Irving Berlin	TBD	TBD	PSA pane of 20	TBD

Note Descriptions

C: Change in previously announced date, site, and/or rate

N: New issue

P: Pictorial first day postmark

+ Customers must affix additional postage to bring total postage to at least the minimum First-Class Mail rate for an envelope or stamped card, depending on which is used. Also, the cost for a stamped envelope is the value of the postage plus 8 cents, and the cost for a stamped card is the value of the postage plus 2 cents.

Pictorial Cancellations Announcement

As a community service, the Postal Service offers pictorial cancellations to commemorate local events celebrated in communities throughout the nation. A list of events for which pictorial cancellations are authorized appears below. If available, the sponsor of the pictorial cancellation appears in italics under the date. Also provided, as space permits, are illustrations of those cancellations that were reproducible and available at press time.

People attending these local events may obtain the cancellation in person at the temporary Post Office station established there. Those who cannot attend the event, but who wish to obtain the cancellation, may submit a mail order request. Pictorial cancellations are available only for the dates indicated, and *requests must be post-marked no later than 30 days following the requested pictorial cancellation date.*

All requests must include a stamped envelope or postcard bearing at least the minimum First-Class Mail postage. Items submitted for cancellation may not include

postage issued after the date of the requested cancellation. Such items will be returned unserved.

Customers wishing to obtain a cancellation should affix stamps to any envelope or postcard of their choice, address the envelope or postcard to themselves or others, insert a card of postcard thickness in envelopes for sturdiness, and tuck in the flap. Place the envelope or postcard in a larger envelope and address it to: PICTORIAL CANCELLATIONS, followed by the NAME OF THE STATION, ADDRESS, CITY, STATE, ZIP + 4 CODE, exactly as listed below (using all capitals and no punctuation, except the hyphen in the ZIP + 4 code).

Customers can also send stamped envelopes and postcards without addresses for cancellation, as long as they supply a larger envelope with adequate postage and their return address. After applying the pictorial cancellation, the Postal Service returns the items (with or without addresses) under addressed protective cover.

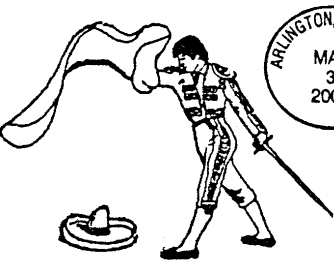

CINCO de MAYO STATION

May 3, 2002

Arlington Post Office
CINCO DE MAYO STATION
POSTMASTER
4108 SW GREEN OAKS BLVD
ARLINGTON TX 76017-9998

Childress Post Office
CINCO DE MAYO STATION
POSTMASTER
507 AVE F NW
CHILDRESS TX 79201-9998

Coleman Post Office
CINCO DE MAYO STATION
POSTMASTER
201 WEST PECAN ST
COLEMAN TX 76834-9998

Colorado City Post Office
CINCO DE MAYO STATION
POSTMASTER
116 WEST 3RD ST
COLORADO CITY TX 79512-9998

Comanche Post Office
CINCO DE MAYO STATION
POSTMASTER
110 EAST GRAND
COMANCHE TX 76442-9998

Lamesa Post Office
CINCO DE MAYO STATION
POSTMASTER
202 NORTH AVE G
LAMESA TX 79331-9998

Lubbock Post Office
CINCO DE MAYO STATION
POSTMASTER
1515 AVE G
LUBBOCK TX 79401-9998

Post Office
CINCO DE MAYO STATION
POSTMASTER
202 WEST MAIN
POST TX 79356-9998

Wichita Falls Post Office
CINCO DE MAYO STATION
POSTMASTER
1000 LAMAR ST
WICHITA FALLS TX 76307-9998

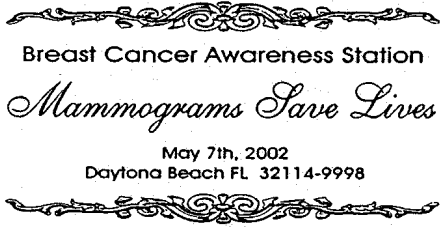

Breast Cancer Awareness Station
Mammograms Save Lives
May 7th, 2002
Daytona Beach FL 32114-9998

May 7, 2002

USPS
BREAST CANCER AWARENESS STATION
POSTMASTER
500 BILL FRANCE BLVD
DAYTONA BEACH FL 32114-9998

USPS
BREAST CANCER AWARENESS STATION
POSTMASTER
4800 SW 34TH ST
GAINESVILLE FL 32608-9998

USPS
BREAST CANCER AWARENESS STATION
POSTMASTER
1100 KINGS RD
JACKSONVILLE FL 32203-9998

USPS
BREAST CANCER AWARENESS STATION
POSTMASTER
400 SW 1ST AVE
OCALA FL 34478-9998

USPS
BREAST CANCER AWARENESS STATION
POSTMASTER
1336 SHERMAN AVE
PANAMA CITY FL 32401-9998

USPS
BREAST CANCER AWARENESS STATION
POSTMASTER
1400 WEST JORDAN ST
PENSACOLA FL 32501-9998

USPS
BREAST CANCER AWARENESS STATION
POSTMASTER
2800 SOUTH ADAMS ST
TALLAHASSEE FL 32301-9998



**SUMTER COUNTY
RELAY FOR LIFE STATION**
APRIL 19, 2002
SUMTERVILLE, FL 33585

April 19, 2002

SUMTER COUNTY RELAY FOR LIFE STATION
POSTMASTER
PO BOX 9998
SUMTERVILLE FL 33585-9998



Many Cultures. One World.
WORLD OF NATIONS
10TH ANNUARY CELEBRATION STATION
JACKSONVILLE FL 32203 APRIL 26, 2002

April 26-28, 2002

City of Jacksonville/Office of Mayor

WORLD OF NATIONS 10TH ANNIVERSARY CELEBRATION STATION
POSTMASTER
1100 KINGS RD
JACKSONVILLE FL 32203-9998



celebrate the
American spirit
VOLUNTEER!
Station
April 24, 2002
Omaha NE 68102

April 24, 2002

United Way

VOLUNTEER STATION
POSTMASTER
1124 PACIFIC ST
OMAHA NE 68108-9998

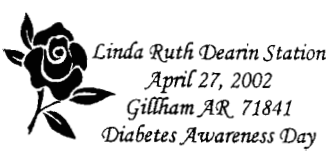

Linda Ruth Dearin Station
April 27, 2002
Gillham AR 71841
Diabetes Awareness Day

April 27, 2002

USPS
LINDA RUTH DEARIN STATION
POSTMASTER
PO BOX 9998
GILLHAM AR 71841-9998



Piano Reflections
ELLIS MARSALIS JR. STATION
APRIL 25, 2002
NEW ORLEANS, LA 70113

April 25-28, 2002

New Orleans Jazz & Heritage Foundation Inc

ELLIS MARSALIS JR STATION
POSTMASTER
PO BOX 58980
NEW ORLEANS LA 70158-8980



THIRD ANNUAL
COTTON PICKIN
FESTIVAL HERITAGE DAY
Station April 27, 2002
Taylor, TX 76754

April 27, 2002

Taylor Main Street Board

COT N PIC N STATION
POSTMASTER
PO BOX 9998
TAYLOR TX 78621-9998



**The California
ADVOCATE**
Station April 26, 2002 Fresno CA 93706

April 26, 2002

THE CALIFORNIA ADVOCATE STATION
POSTMASTER
PO BOX 9998
FRESNO CA 93706-9998



Greetings from
APR 27 2002
WICHITA FALLS, TX 76707
STATION
AMERICA

April 27, 2002

Wichita Falls Post Office

GREETINGS FROM AMERICA STATION
POSTMASTER
1000 LAMAR
WICHITA FALLS TX 76307-9989



April 27, 2002
Washington County 4-H
Youth Fair Station
Springfield, Ky 40069

April 27, 2002
Washington County 4-H
WASHINGTON COUNTY 4-H
YOUTH FAIR STATION
POSTMASTER
PO BOX 9998
SPRINGFIELD KY 40069-9998



May 3-4, 2002
Esperanza Bonanza Festival
ESPERANZA BONANZA
STATION
POSTMASTER
PO BOX 9998
MARION AR 72364-9998



April 29, 2002
Longleaf Pine Forest
NATURE OF AMERICA STATION
POSTMASTER
1302 INDUSTRIAL AVE
NORTH PLATTE NE 69101-9998



May 3, 2002
Churchill Downs
128TH KENTUCKY OAKS
STATION
POSTMASTER
PO BOX 9998
LOUISVILLE KY 40231-9998



VETERANS OF FOREIGN WARS
OF THE UNITED STATES
AND ITS LADIES AUXILIARY
DEPARTMENT OF
ARKANSAS
LOYALTY DAY
CELEBRATION STATION
ROGERS AR 72756
MAY 1, 2002

May 1, 2002
VFW Post 3031
LOYALTY DAY CELEBRATION
STATION
POSTMASTER
PO BOX 9998
ROGERS AR 72756-9998

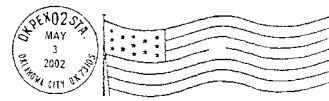

May 3-5, 2002
Okpex Stamp Club
OKPEX 02 STATION
POSTMASTER
320 SW 5TH ST
OKLAHOMA CITY OK
73125-9998



May 2-5, 2002
New Orleans Jazz and Heritage Foundation Inc
JAZZ FEST STATION
POSTMASTER
PO BOX 58980
NEW ORLEANS LA 70158-8980

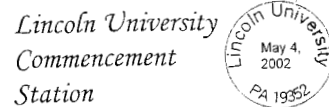

May 4, 2002
Lincoln University
LINCOLN UNIVERSITY
COMMENCEMENT STATION
301 ASHMUN AVE
LINCOLN UNIVERSITY PA
19352-9998

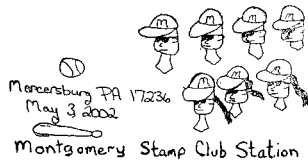

May 3, 2002
Montgomery Elementary School Stamp Club
MONTGOMERY STAMP CLUB
STATION
POSTMASTER
PO BOX 9998
MERCERSBURG PA
17236-9998

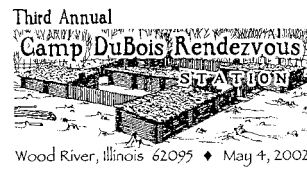

May 4, 2002
Wood River Museum and Visitor Center Committee
3RD ANNUAL CAMP DUBOIS
RENDEZVOUS STATION
POSTMASTER
161 EAST FERGUSON AVE
WOOD RIVER IL 62095-9998



May 3, 2002
USPS
BREAST CANCER RESEARCH
STATION
POSTMASTER
PO BOX 9998
SHERIDAN AR 72150-9998



May 4, 2002
Conestoga District, Cradle of Liberty Council, Boy Scouts of America
CAMPOREE STATION
POSTMASTER
PO BOX 9998
GREEN LANE PA 18054-9998



May 3, 2002
Iris Festival
IRIS FESTIVAL STATION
POSTMASTER
PO BOX 9998
PONCA CITY OK 74601-9998

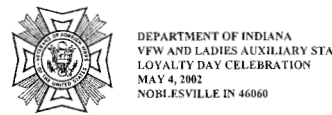

May 4, 2002
VFW AND LADIES AUXILIARY STATION
POSTMASTER
1900 PLEASANT RD
NOBLESVILLE IN 46060-9998



May 4, 2002
 Churchill Downs
 128TH KENTUCKY DERBY STATION
 POSTMASTER
 PO BOX 9998
 LOUISVILLE KY 40231-9998

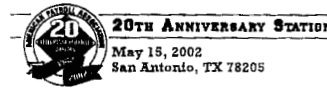

May 15, 2002
 20TH ANNIVERSARY STATION
 POSTMASTER
 PO BOX 9998
 SAN ANTONIO TX 78205-9998



May 4, 2002
 Professional Wrestling Hall of Fame
 PROFESSIONAL WRESTLING HALL OF FAME STATION
 POSTMASTER
 29 JAY ST
 SCHENECTADY NY 12305-9998



May 17, 2002
 USPS
 GEORGIA PUBLIC SAFETY MEMORIAL STATION
 POSTMASTER
 165 WEST JOHNSTON ST
 FORSYTH GA 31029-9998

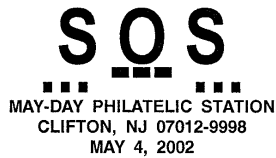

May 4-5, 2002
 MAY-DAY PHILATELIC STATION
 POSTMASTER
 45 WASHINGTON AVE
 CLIFTON NJ 07011-9998



May 17, 2002
 Colorado NALC State Convention
 FORT COLLINS CENTENNIAL CELEBRATION STATION
 POSTMASTER
 301 EAST BOARDWALK DR
 FORT COLLINS CO 80525-9998



May 4-5, 2002
 Toad Suck Daze Festival
 TOAD SUCK DAZE STATION
 POSTMASTER
 PO BOX 9998
 CONWAY AR 72032-9998



May 17, 2002
 Armagh Elementary School Stamp Club
 STAMP CLUB STATION
 POSTMASTER
 PO BOX 9998
 MILROY PA 17063-9998



May 4-5, 2002
 Nevada Hispanic Services
 CINCO DE MAYO STATION
 POSTMASTER
 2000 VASSAR ST
 RENO NV 89510-9998



May 17-18, 2002
 Wilton Arts Association
 ARTS AND FILM FESTIVAL STATION
 OFFICER IN CHARGE
 79 MAIN ST
 WILTON NH 03086-9998

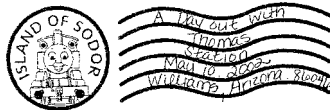

May 10, 2002
 USPS
 A DAY OUT WITH THOMAS STATION
 POSTMASTER
 PO BOX 9998
 WILLIAMS AZ 86046-9998

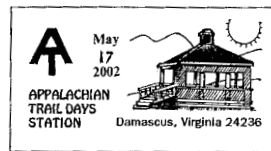

May 17-19, 2002
 Appalachian Trail Days Comm
 APPALACHIAN TRAIL DAYS STATION
 POSTMASTER
 211 NORTH REYNOLDS ST
 DAMASCUS VA 24236-9998



May 14, 2002
 Unicolor Corporation
 OLD GLORY STATION
 POSTMASTER
 2970 MARKET ST ROOM 525
 PHILADELPHIA PA 19104-9611

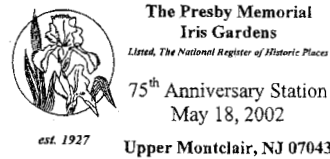

May 18, 2002
 THE PRESBY MEMORIAL IRIS GARDEN 75TH ANNIVERSARY STATION
 POSTMASTER
 125 GLENRINGE AVE
 MONTCLAIR NJ 07042-9998

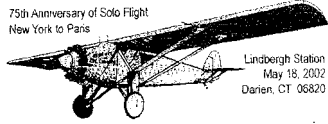

May 18, 2002
 USPS Darien CT Public Library
 LINDBERGH STATION
 POSTMASTER
 30 CORBIN DR
 DARIEN CT 06820-9998



INDIANA TOWNSHIP
 6TH ANNUAL YOUTH DAY STA
 Saturday, May 18th, 2002
 Emmerling Community Park
 INDIANOLA, PA 15051

May 18, 2002
Indiana Twp
 INDIANA TOWNSHIP 6TH
 ANNUAL YOUTH DAY STATION
 POSTMASTER
 PO BOX 9998
 INDIANOLA PA 15051-9998



MAY 18, 2002
 Celebrating a
 Quarter of a Century of
 Pender Pride
 Burgaw NC 28425

May 18, 2002
 USPS
 PENDERSPRINGFEST STATION
 POSTMASTER
 100 EAST SATCHWELL ST
 BURGAW NC 28425-9998



OSCODA COUNTY STATION
 MAY 18, 2002
 MIO MI 48647

May 18, 2002
 OSCODA COUNTY STATION
 POSTMASTER
 PO BOX 9998
 MIO MI 48647-9998

ARMED FORCES DAY STATION

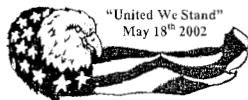

Hawthorne Nevada 89415

May 18, 2002
 USPS
 ARMED FORCES DAY STATION
 POSTMASTER
 PO BOX 9998
 HAWTHORNE NV 89415-9998

UNION CANAL
 TUNNEL STATION
 LEBANON PA.17048
 MAY18, 2002



May 18, 2002
New Image QWL/EI Workteam
 UNION CANAL TUNNEL
 STATION
 POSTMASTER
 PO BOX 9998
 LEBANON PA 17042-9998



SOUTH CHARLESTON, WV 25303

May 18, 2002
 City of South Charleston
 BRANCH MANAGER STATION
 POSTMASTER
 400 D ST
 SOUTH CHARLESTON WV
 25303-9998

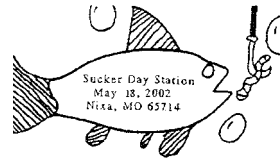

Sucker Day Station
 May 18, 2002
 Nixa, MO 65714

May 18, 2002
Sucker Day Committee
 SUCKER DAY STATION
 POSTMASTER
 PO BOX 9998
 NIXA MO 65714-9998



Friends of the Library
 LAWN SALE STATION
 May 18, 2002
 Kingsville Public Library
 Kingsville OH 44048

May 18, 2002
 Kingsville Public Library
 LAWN SALE STATION
 POSTMASTER
 3110 WEST MAIN ST
 KINGSVILLE OH 44048-9998



Jerome Home Tour Station
 May 18, 2002
 Jerome, AZ 86331

May 18, 2002
 USPS
 JEROME HOME TOUR STATION
 POSTMASTER
 PO BOX 9998
 JEROME AZ 86331-9998



Honoring
 America's
 Heroes

Erie Town Fair 572

May 18, 2002
 USPS Erie Co
 ERIE TOWN FAIR STATION
 POSTMASTER
 150 WELLS ST
 ERIE CO 80516-9998



Ola and Per
 Come Home
 Station
 May 18 2002
 Spring Grove MN
 55974



May 18, 2002
Ola and Per Committee
 OLA AND PER COME HOME
 STATION
 POSTMASTER
 PO BOX 9998
 SPRING GROVE MN
 55974-9998

RACE FOR THE CURE
 RELAY FOR LIFE
 STATION
 18 MAY 2002
 WARREN OH 44482



May 18, 2002
 Warren Stamp Club
 RACE FOR THE CURE RELAY
 FOR LIFE STATION
 POSTMASTER
 PO BOX 9998
 WARREN OH 44481-9998

Picklefest Station
 May 18, 2002
 Atkins AR 72823



May 18, 2002
People for a Better Atkins Inc
 PICKLEFEST STATION
 POSTMASTER
 PO BOX 9998
 ATKINS AR 72823-9998

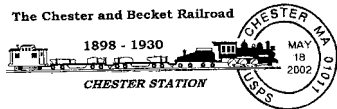

May 18, 2002
 The Chester Foundation
 CHESTER STATION
 POSTMASTER
 PO BOX 9998
 CHESTER MA 01011-9998



May 18-19, 2002
 SYTTENDE MAI STATION
 POSTMASTER
 PO BOX 9998
 STOUGHTON WI 53589-9998



May 18, 2002
 D.C. Booth National Historic Fish Hatchery
 CONSERVING AMERICAS FISHERIES SPEARFISH STATION
 POSTMASTER
 PO BOX 9998
 SPEARFISH SD 57783-9998



May 18-19, 2002
 Coffeyville Stamp Club
 CSC STATION
 POSTMASTER
 232 WEST 8TH ST
 COFFEYVILLE KS 67337-9998



May 18, 2002
 Old Colony Council
 OLD COLONY COUNCIL STATION
 POSTMASTER
 124 MAIN ST
 CARVER MA 02330-9998

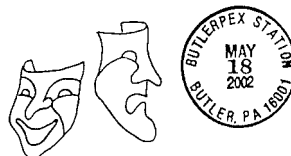

May 18-19, 2002
 Butler County Philatelic Society
 BUTLERPEX STATION
 POSTMASTER
 345 SOUTH MAIN ST
 BUTLER PA 16001-9998

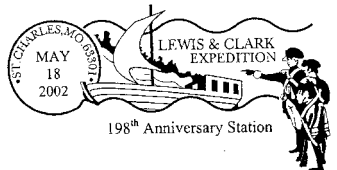

May 18-19, 2002
 Lewis and Clark Heritage Day Committee
 LEWIS AND CLARK 198TH ANNIVERSARY STATION
 POSTMASTER
 112 SOUTH 5TH ST
 ST CHARLES MO 63301-9998



May 20, 2002
 USPS
 MENTORING PARTNERSHIP STATION
 POSTMASTER
 11 ELMWOOD AVE
 BURLINGTON VT 05401-9711

Colchester Chamber of Commerce
 Covered Bridge Festival
 May 18, 2002



Celebrating the Fourth Annual Downsville Covered Bridge Festival
 Covered Bridge Station, Downsville, NY 13755

May 18-19, 2002
 Colchester Chamber of Commerce
 COVERED BRIDGE STATION
 POSTMASTER
 15126 STATE HIGHWAY 30
 DOWNSVILLE NY 13755-9998



May 20, 2002
 American Topical Assoc Masonic Study Unit
 ATA MASONIC STUDY UNIT STATION
 POSTMASTER
 PO BOX 9998
 GARDEN CITY NY 11530-9998



May 18-19, 2002
 USPS
 ANNIVERSARY STATION
 POSTMASTER
 312 WEST CHURCH ST
 WAKEFIELD VA 23888-9998



May 20, 2002
 Unicover Corporation
 NEW ORLEANS STATION
 POSTMASTER
 701 LOYOLA AVE
 NEW ORLEANS LA 70113-9998

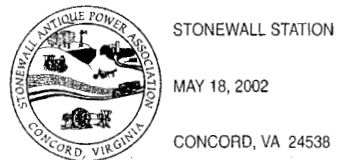

May 18-19, 2002
 Stonewall Antique Power
 STONEWALL STATION
 POSTMASTER
 PO BOX 9998
 CONCORD VA 24538-9998

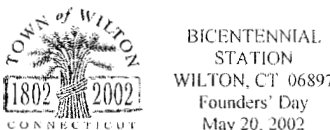

May 20, 2002
 Town of Wilton
 BICENTENNIAL STATION
 POSTMASTER
 15 HUBBARD RD
 WILTON CT 06897-9998



May 20-26, 2002
 Webster County Woodchopping Assoc
 WEBSTER SPRINGS STATION
 POSTMASTER
 100 BANK FOLK ST
 WEBSTER SPRINGS WV
 26288-9998

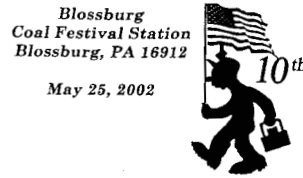

May 25, 2002
 Coal Festival Committee
 BLOSSBURG COAL FESTIVAL STATION
 POSTMASTER
 PO BOX 9998
 BLOSSBURG PA 16912-9998

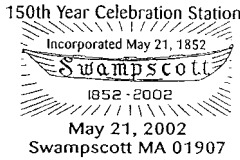

May 21, 2002
 Town of Swampscott
 150TH YEAR CELEBRATION STATION
 STATION MANAGER
 49 ELMWOOD RD
 SWAMPSCOTT MA 01907-9998



May 25, 2002
 COMPLEX STATION
 POSTMASTER
 909 WEST EUCLID AVE
 ARLINGTON HEIGHTS IL
 60004-9998



May 22, 2002
 Crater Lake National Park
 CENTENNIAL STATION
 POSTMASTER/PHILATELIC SERVICES
 317 7TH ST
 KLAMATH FALLS OR
 97601-9998

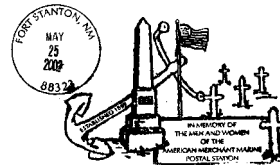

May 25, 2002
 American Merchant Marine
 AMERICAN MERCHANT MARINE POSTAL STATION
 POSTMASTER
 PO BOX 9998
 FORT STANTON NM
 88323-9998



May 23-27, 2002
 Koniag Inc
 CRAB FESTIVAL STATION
 POSTMASTER
 PO BOX 9998
 KODIAK AK 99615-9998



May 25, 2002
 Protection High School Alumni Weekend
 ALUMNI STATION
 POSTMASTER
 PO BOX 9998
 PROTECTION KS 67127-9998



May 24, 2002
 Third Grade Students
 Little Egg Harbor Intermediate School
 Little Egg Harbor NJ 08087
 THESE COLORS DONT RUN STATION
 POSTMASTER
 200 MATHISTOWN RD
 MYSTIC ISLAND NJ 08087-9998



25th Annual
 Irish Festival Station
 May 25, 2002
 East Durham, NY 12423

May 25, 2002
 IRISH FESTIVAL STATION
 POSTMASTER
 PO BOX 9998
 EAST DURHAM NY 12423-9998



May 24, 2002
 Thomas Chamber of Commerce
 THOMAS CENTENNIAL STATION
 POSTMASTER
 108 N MAIN
 THOMAS OK 73669-9998

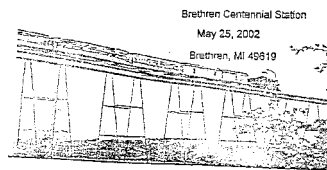

May 25, 2002
 Brethren Heritage Brethren Boosters
 BRETHREN CENTENNIAL STATION
 POSTMASTER
 PO BOX 9998
 BRETHREN MI 49619-9998



May 24, 2002
 COMPLEX STATION
 POSTMASTER
 909 WEST EUCLID AVE
 ARLINGTON HEIGHTS IL
 60006-9998

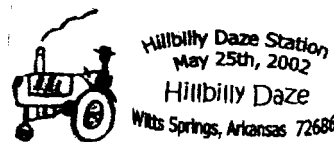

May 25, 2002
 Extension Homemakers Club
 Wits Springs EH Club
 HILLBILLY DAZE STATION
 POSTMASTER
 PO BOX 9998
 WITTS SPRINGS AR
 72686-9998



May 25, 2002
Prince of Wales International
 MARATHON STATION
 POSTMASTER
 PO BOX 9998
 CRAIG AK 99921-9998



IDLEWILD PARK
 125TH ANNIVERSARY STATION
 MAY 26, 2002
 LIGONIER PA 15658

May 26, 2002
Idlewild Park
 IDLEWILD 125TH
 ANNIVERSARY STATION
 POSTMASTER
 PO BOX 9998
 LIGONIER PA 15658-9998

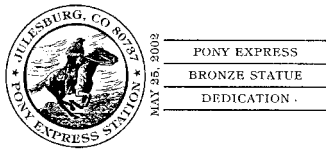

May 25, 2002
NPEA Colorado Division
 PONY EXPRESS STATION
 POSTMASTER
 319 PINE
 JULESBURG CO 80737-9998



BOLDER-BOLDER
 BOLDER BOULDER STATION
 MAY 27, 2002 • BOLDER, COLORADO 80309

May 27, 2002
Bolder Boulder
 BOLDER BOULDER STATION
 PHILATELIC CLERK
 1905 15TH ST
 BOULDER CO 80302-9998

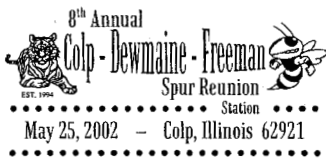

May 25-27, 2002
Community Reunion Members
 8TH ANNUAL COLP DEWMAIME
 FREEMAN SPUR REUNION
 STATION
 POSTMASTER
 PO BOX 9998
 COLP IL 62921-9998



May 27, 2002
Henderson School Alumni
 70TH ANNIVERSARY
 HENDERSON SCHOOL
 STATION
 POSTMASTER
 8872 STATE RT 178
 HENDERSON NY 13650-9998



May 25-27, 2002
NOJEX Stamp Show
 NOJEX STATION
 POSTMASTER
 310 NORTH BROAD ST
 ELIZABETH NJ 07207-9998



May 27, 2002
 135th MEMORIAL DAY PARADE
 STATION
 PARMA HEIGHTS, OH 44130

May 27, 2002
 135TH MEMORIAL DAY PARADE
 STATION
 MIDPARK POST OFFICE
 13301 SMITH RD
 CLEVELAND OH 44130-9998



May 26, 2002
 INDIANAPOLIS 500 STATION
 POSTMASTER
 125 WEST SOUTH ST
 INDIANAPOLIS IN 46206-9998

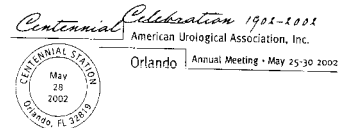

May 26-28, 2002
American Urological Association Inc
 CENTENNIAL STATION
 POSTMASTER
 10401 POST OFFICE BLVD
 ORLANDO FL 32862-9998



May 26, 2002
City of St Clair Shores
 MEMORIAL DAY PARADE
 STATION
 POSTMASTER
 23125 GREATER MACK AVE
 ST CLAIR SHORES MI
 48080-9998

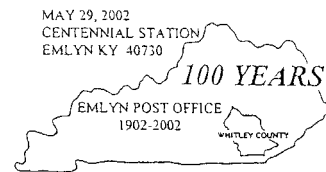

May 27, 2002
Emlyn Church of God
 CENTENNIAL STATION
 POSTMASTER
 PO BOX 9998
 EMLYN KY 40730-9998



May 26, 2002
 COMPEX STATION
 POSTMASTER
 909 WEST EUCLID AVE
 ARLINGTON HEIGHTS IL
 60004-9998

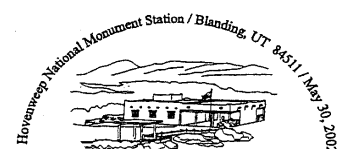

May 30, 2002
USPS Blanding
 HOVENWEEP NATIONAL
 MONUMENT STATION
 POSTMASTER
 90 NORTH MAIN
 BLANDING UT 84511-9998



May 30, 2002
 Malden Booster Club
 JOHN WAYNE PIONEER
 WAGONS & RIDERS STATION
 POSTMASTER
 1 SOUTH MAIN ST
 MALDEN WA 99149-9998

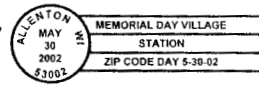

May 30, 2002
 MEMORIAL DAY VILLAGE
 STATION
 POSTMASTER
 PO BOX 9998
 ALLENTON WI 53002-9998

— Stamp Services,
 Government Relations and Public Policy, 5-16-02

Special Cancellation Die Hubs

Postmasters and plant managers who have any of the special cancellation die hubs listed below may use them for the periods designated. At the end of the period, these die

hubs must be withdrawn and stored. Postmasters and plant managers who do not have these special die hubs may not request them from the sponsors.

Cancellation	Period of Use
Only You Can Prevent Forest Fires	April 1–Oct. 31
National Salvation Army Week, 4 th Week in May	May 1–May 31
Support Research for “NF,” Neurofibromatosis	May 1–May 31
Support Your Mental Health Association	May 1–May 31
National Flag Day, June 14, Pause for the Pledge	May 1–June 14
Goodwill Industries — Our Business Works So People Can	May 1–June 30
National Transportation Week	May 14–May 20
Fight Disease, Support City of Hope Pilot Medical Center	May 15–June 15
Defeat Muscular Dystrophy, Support MDAA	May 15–June 17
Conquer Multiple Sclerosis	May 17–June 17
Conquer Cystic Fibrosis	Sept. 1–Sept. 30
Peace Corps Anniversary, Making a Difference	Sept. 1–Oct. 31
Employ People With Disabilities	Sept. 1–Nov. 30
Give to the United Way	Sept. 15–Nov. 15
Learn About Lupus, October Is Lupus Awareness Month	Oct. 1–Oct. 31
Radon Action Week, Protect Your Family, Test Your Home	Oct. 1–Oct. 31
Support Infection Control Week	Oct. 1–Nov. 30
Help Retarded Children	Nov. 1–Nov. 30
Military Families Recognition Day	Nov. 1–Nov. 30
National Adoption Month	Nov. 1–Nov. 30
National Philanthropy Day, Love of Humankind	Nov. 1–Nov. 30
Use Christmas Seals, Support Your Lung Association	Nov. 8–Dec. 31
Support American Education Week	Nov. 10–Nov. 30
Autistic Children, Hope Through Research and Education	Dec. 1–Dec. 31

— Mail Preparation and Standards,
 Pricing and Classification, 5-16-02

Post Offices

Post Office Changes

Old/ New	Finance No.	ZIP Code	State	P.O. Name	County/ Parish	Station/Branch/ Unit	Unit Type	Effective Date	Comments
Old	10-5000	20007	DC	Washington	District of Columbia	Georgetown	Classified Station	05/07/2002	Establish a new ZIP Code for Post Office boxes. Use Washington DC 20027 as last line of address for 923 Post Office boxes previously in ZIP Code 20007.
New	10-5000	20027	DC	Washington	District of Columbia	Georgetown	Classified Station	05/07/2002	
Old	10-5000	20002	DC	Washington	District of Columbia	Northeast	Classified Station	05/07/2002	Establish a new ZIP Code for Post Office boxes. Use Washington DC 20022 as last line of address for 748 Post Office boxes previously in ZIP Code 20002.
New	10-5000	20022	DC	Washington	District of Columbia	Northeast	Classified Station	05/07/2002	
Old	10-5000	20003	DC	Washington	District of Columbia	Southeast	Classified Station	05/07/2002	Establish a new ZIP Code for Post Office boxes. Use Washington DC 20023 as last line of address for 832 Post Office boxes previously in ZIP Code 20003.
New	10-5000	20023	DC	Washington	District of Columbia	Southeast	Classified Station	05/07/2002	
Old	11-5925	32030	FL	Orange Park	Clay	Doctors Inlet	Community Post Office	11/16/2001	Community Post Office discontinued. Retain ZIP Code and place name. Continue to use Doctors Inlet FL 32030 as last line of address.
New	11-6885	32030	FL	Orange Park	Clay	Doctors Inlet	Place Name	11/16/2001	
Old	11-1290	33439	FL	Canal Point	Palm Beach	Bryant	Community Post Office	06/19/1999	Community Post Office discontinued. Retain ZIP Code and place name. Continue to use Bryant FL 33439 as last line of address.
New	11-1290	33439	FL	Canal Point	Palm Beach	Bryant	Place Name	06/19/1999	
Old	11-2385	34431	FL	Dunnellon	Marion	Rainbow Lakes	Community Post Office	07/01/2001	Community Post Office and place name discontinued. Continue to use Dunnellon FL 34431 as last line of address.
New	11-2385	34431	FL	Dunnellon	Marion	Main Office	Post Office	07/01/2001	
Old	11-3750	32563	FL	Holt	Santa Rosa	Harold	Community Post Office	07/01/2001	Community Post Office discontinued. Continue to use Gulf Breeze FL 32563 as last line of address.
New	11-3660	32563	FL	Gulf Breeze	Santa Rosa	Main Office	Post Office	07/01/2001	
Old	11-5250	33547	FL	Lithia	Hillsborough	Main Office	Post Office	08/10/2002	This ZIP Code realignment has been cancelled. This amends <i>Postal Bulletin</i> 22075.
New	11-9600	33598	FL	Wimauma	Hillsborough	Main Office	Post Office	08/10/2002	

Old/ New	Finance No.	ZIP Code	State	P.O. Name	County/ Parish	Station/Branch/ Unit	Unit Type	Effective Date	Comments
Old	18-5058	51017	IA	Lemars	Plymouth	Craig	Community Post Office	03/09/2002	Community Post Office and ZIP Code discontinued. Establish a place name. Craig IA becomes an acceptable last line for use with ZIP Code 51031.
New	18-5058	51031	IA	Lemars	Plymouth	Craig	Place Name	03/09/2002	
Old	25-8990	49813	MI	Stephenson	Menominee	Cedar River	Community Post Office	12/11/2001	Community Post Office and ZIP Code discontinued. Establish a place name. Cedar River becomes an acceptable last line for use with ZIP Code 49887.
New	25-8990	49887	MI	Stephenson	Menominee	Cedar River	Place Name	12/11/2001	
Old	36-1392	28211	NC	Charlotte	Mecklenburg	Southpark	Classified Station	04/13/2002	Classified Station discontinued. Continue to use Charlotte NC 28211 as last line of address.
New	36-1392	28211	NC	Charlotte	Mecklenburg	Randolph	Classified Station	04/13/2002	
Old	37-8304	58553	ND	Sterling	Burleigh	McKenzie	Community Post Office	11/24/2001	Community Post Office and ZIP Code discontinued. Establish a place name. McKenzie ND becomes an acceptable last line for use with ZIP Code 58572.
New	37-8304	58572	ND	Sterling	Burleigh	McKenzie	Place Name	11/24/2001	
Old	48-2030	78350	TX	Corpus Christi	Live Oak	Dinero	Community Post Office	05/01/2002	This announcement changes the administrative office for this ZIP Code from Corpus Christi TX to Mathis TX. Continue to use Dinero TX 78350 as last line for addresses.
New	48-5725	78350	TX	Mathis	Live Oak	Dinero	Community Post Office	05/01/2002	
Old	56-3040	54851	WI	Frederic	Polk	Lewis	Community Post Office	12/15/2001	Community Post Office and ZIP Code discontinued. Establish a place name. Lewis WI becomes an acceptable last line for use with ZIP Code 54837.
New	56-3040	54837	WI	Frederic	Polk	Lewis	Place Name	12/15/2001	

Postal Employees

NEW PERFORMANCE TOOL

LEAD — Leadership Excellence at the Desktop

Employee Development, in partnership with the Center for Creative Leadership and PBS The Business and Technology Network, offers Postal Service leaders a real-time performance support tool called LEAD — Leadership Excellence at the Desktop.

LEAD is designed for high-potential and seasoned managers, executives, and anyone else who manages or supervises.

LEAD's features include:

- Interactive exercises.
- Audio and video-streamed role-plays.
- E-mail links.
- Frequently asked questions.
- Notebook that enables personalized comments to assist in continuous improvement.

LEAD's programs include:

- Developing Effective Interpersonal Relationships.
- Adapting to Change.
- Building and Leading a Team.
- Meeting Business Objectives.
- Developing a Broad Organizational Perspective.

LEAD is based on management and leadership research conducted by the Center for Creative Leadership — the research base used to support the Postal Service's Advanced Leadership Program. **Note:** Because LEAD is a support tool, not a training course, the Postal Service cannot provide training hours for LEAD.

You can order LEAD from the Material Distribution Center (MDC) by one of the following means:

- **Touch tone order entry:** Call the MDC at 800-332-0317, choose option 1, then option 2.
- **E-mail:** Complete PS Form 7380, *MDC Supply Requisition* (manually or by F3 Fill), and send it as an attachment to the e-mail address *MDC Customer Service*.
- **Mail:** Complete and mail PS Form 7380 to the MDC at the following address:

SUPPLY REQUISITIONS
MATERIAL DISTRIBUTION CENTER
500 SW GARY ORMSBY DR
TOPEKA KS 66624-9702

The relevant ordering information for LEAD is as follows:

PSN: 7025-05-000-4902
Unit of Issue: Each
Price: \$5.00

— *Employee Development,
Employee Resource Management, 5-16-02*

HANDBOOK EL-806 REVISION

Seizures/Epilepsy — New-Hire Applicants

Effective May 16, 2002, Handbook EL-806, *Health and Medical Service*, is revised. The new language about seizures, seizure disorders, and epilepsy applies to applicants for Postal Service employment.

We will incorporate this revision into the next printed edition of Handbook EL-806.

Handbook EL-806, Health and Medical Service

1	Administrative Procedures	*	*	*	*	*
150	Unsuitability Policy Provisions	*	*	*	*	*
153	Seizures/Epilepsy	*	*	*	*	*

[Revise heading and text of 153.4 to read as follows:]

153.4 New-Hire Candidates

Any applicant for Postal Service employment who has a history of or presently has seizures, a seizure disorder, or epilepsy must present documentation to the Postal contract physician, medical director, or occupational health nurse administrator that fully describes the extent of the disorder, treatment program, prognosis, and any other relevant information. This documentation must contain information addressing the applicant's level of seizure control such as medication levels and/or period of time seizure free and will be introduced as part of the documentation considered during the medical assessment/suitability process. The medical director or occupational health nurse administrator may request additional information from the applicant if deemed necessary. Special emphasis will be placed upon the ability of the individual to work safely.

* * * * *

— *Health and Resource Management,
Employee Resource Management, 5-16-02*

USPS-APWU NATIONAL AGREEMENT

Changes to Regular Uniform and Work Clothes Programs Allowances 2000–2003

Employees covered under the 2000–2003 USPS–APWU National Agreement who are eligible to receive annual clothing allowances, as specified in *Employee and Labor Relations Manual* (ELM) 932.1, are entitled to an annual allowance increase of 4.5 percent, effective on allowance anniversary dates occurring on or after November 21, 2001, as follows.

Regular Uniform Program

See ELM 932.11, Regular Uniforms, for additional information.

Current Amount	New Amount
\$291	\$304
\$358 (first-year employee)	\$374
\$125	\$131
\$140 (first-year employee)	\$147

Work Clothes Program

See ELM 932.13, Work Clothes, for additional information.

Current Amount	New Amount
\$57	\$60
\$113 (Contract Program – Custodial Maintenance, BMEU)	\$118
\$142 (Contract Program – Vehicle Maintenance)	\$148

Anniversary dates from November 21, 2001, have been updated to reflect the increase. All other allowances will be updated as anniversary dates are due. The next scheduled increase, in accordance with the agreement, will be on November 21, 2002. Applicable allowance increases will be detailed in a future *Postal Bulletin* article.

— *Contract Administration, APWU,
Labor Relations, 5-16-02*

REMINDER

MI EL 410-2002-1, Process for Completing EAS Merit Performance Evaluations and Setting Objectives

Management Instruction (MI) EL 410-2002-1, *Process for Completing EAS Merit Performance Evaluations and Setting Objectives*, dated March 22, 2002, provides guidance on setting objectives and assessing the performance of executive and administrative schedule (EAS) employees. Specifically, the instructions in the MI:

- Acquaint all EAS employees, full- and part-time, with the Postal Service's performance management objectives and philosophy.
- Provide the framework and guidance for managers and their staffs to establish performance objectives at the beginning of each year.
- Emphasize the manager's role in motivating EAS employees on an ongoing basis to achieve an optimum performance level in support of the work unit's mission.
- Clarify the manager's obligation to take constructive action in improving unsatisfactory performance.
- Provide direction for preparing the Midyear Review and the Narrative of Work Accomplishments.

Managers and supervisors with EAS employees have the option of developing a Success Improvement Plan. Jointly developed by the manager and employee, the plan is structured to help employees overcome performance issues.

MI EL-410-2002-1 is available on the Postal Service PolicyNet page at <http://blue.usps.gov/cpim>; click on *MIs*. PS Form 8220, *EAS Merit Performance Evaluation*, which is used for administering and tracking the performance evaluation process, is also available on the Postal Service PolicyNet page at <http://blue.usps.gov/cpim>; click on *Postal Forms*.

More information about Selection, Evaluation, and Recognition's program is available online at <http://blue.usps.gov/hrisp/ser/welcome.htm>.

— *Selection, Evaluation, and Recognition, Employee Resource Management, 5-16-02*

NOTICE TO ALL EMPLOYEES

THRIFT SAVINGS PLAN FACT SHEET

Percentage returns released May 3, 2002, by the Federal Retirement Thrift Investment Board

ANNUAL RETURNS	G Fund	F Fund	LBA Bond Index	C Fund	S&P 500 Stock Index	S * Fund	Wilshire 4500 Stock Index	I * Fund	EAFE Stock Index
1992	7.23	7.20	7.40	7.70	7.62	—	11.87	—	-12.22
1993	6.14	9.52	9.75	10.13	10.08	—	14.57	—	32.68
1994	7.22	-2.96	-2.92	1.33	1.32	—	-2.66	—	7.75
1995	7.03	18.31	18.47	37.41	37.58	—	33.48	—	11.27
1996	6.76	3.66	3.63	22.85	22.96	18.52	17.18	6.27	6.14
1997	6.77	9.60	9.65	33.17	33.36	26.61	25.69	1.46	1.55
1998	5.74	8.70	8.69	28.44	28.58	7.51	8.63	20.46	20.09
1999	5.99	-0.85	-0.82	20.95	21.04	32.70	35.49	26.81	26.72
2000	6.42	11.67	11.63	-9.14	-9.10	-8.76	-15.77	-14.11	-14.17
2001	5.39	8.61	8.44	-11.94	-11.89	-2.22*	-2.52*	-15.42*	-14.88*

*Rates of return for May (inception of S and I Funds) through December 2001.

2001 MONTHLY RETURNS	G Fund	F Fund	LBA Bond Index	C Fund	S&P 500 Stock Index	S Fund	Wilshire 4500 Stock Index	I Fund	EAFE Stock Index
May	0.47	0.61	0.60	0.65	0.67	1.42	2.37	-4.13	-3.53
June	0.47	0.39	0.38	-2.42	-2.43	0.66	0.81	-3.99	-4.09
July	0.48	2.22	2.24	-0.98	-0.98	-4.13	-4.56	-1.79	-1.82
Aug.	0.45	1.20	1.15	-6.27	-6.26	-4.32	-4.77	-2.58	-2.53
Sept.	0.43	1.15	1.16	-8.05	-8.08	-12.50	-12.86	-9.95	-10.13
Oct.	0.41	2.12	2.09	1.85	1.91	5.09	5.24	2.47	2.56
Nov.	0.37	-1.37	-1.38	7.62	7.67	7.84	7.77	3.56	3.69
Dec.	0.42	-0.61	-0.64	0.88	0.88	5.31	5.36	0.52	0.54

2002 MONTHLY RETURNS	G Fund	F Fund	LBA Bond Index	C Fund	S&P 500 Stock Index	S Fund	Wilshire 4500 Stock Index	I Fund	EAFE Stock Index
Jan.	0.45	0.79	0.81	-1.47	-1.46	-2.02	-1.95	-5.33	-5.31
Feb.	0.40	0.98	0.97	-1.92	-1.93	-2.64	-2.83	0.66	0.70
March	0.44	-1.66	-1.66	3.73	3.76	6.83	6.78	5.82	5.41
April	0.46	1.89	1.94	-6.06	-6.06	-1.06	-0.98	0.25	0.66
LAST 12 MONTHS	5.38	7.90	7.84	-12.73	-12.63	-1.42	-1.75	-14.50	-13.88

Fund	Invested In	Index Tracked
G — Government Securities Investment Fund	Special issues of U.S. Treasury securities	N/A
F — Fixed Income Index Investment Fund	Barclays U.S. Debt Index Fund	Lehman Brothers U.S. Aggregate bond index
C — Common Stock Index Investment Fund	Barclays Equity Index Fund	S&P 500 stock index
S — Small Capitalization Stock Index Investment Fund	Barclays Extended Market Index Fund	Wilshire 4500 stock index
I — International Stock Index Investment Fund	Barclays EAFE Index Fund	Europe, Australasia, and Far East stock index

Future performance of the funds will vary and may be significantly different from the returns shown above. See the *Summary of the Thrift Savings Plan* for detailed information about the funds and their investment risks. The monthly returns of the TSP Funds represent net earnings for the month after deduction of accrued administrative

expenses and, except for the G Fund, after deduction of trading costs and accrued investment management fees as well. The returns for the four indexes shown do not include any of these deductions.

* Implemented May 2001.

Please post on bulletin boards. Recycle all previous notices.

CUT ALONG DOTTED LINE



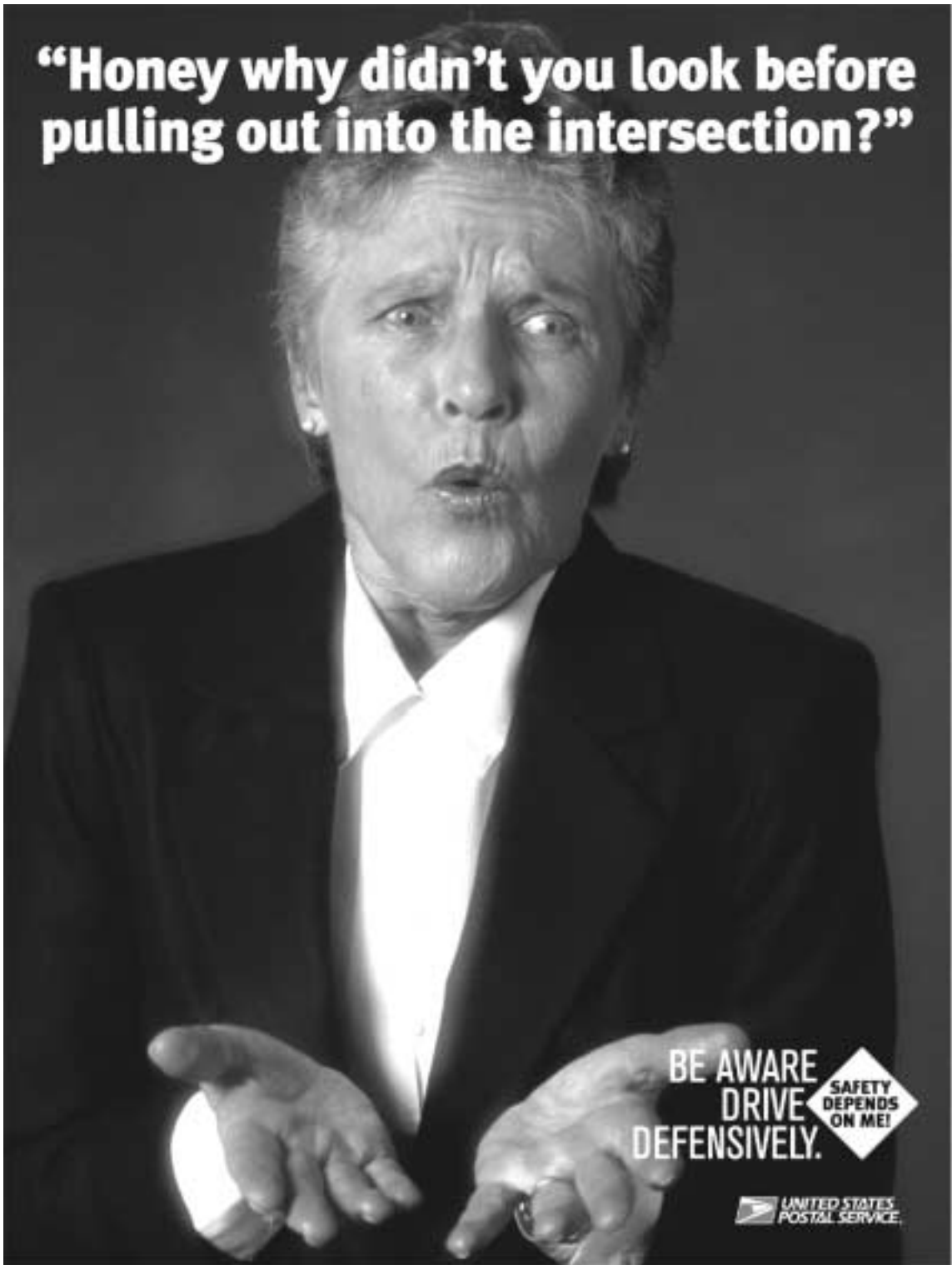

Retail

FIELD NOTIFICATION

E-Mail Notification for Resetting Electronic Manually Reset Meters

Effective May 1, 2002, postal employees stopped resetting meters for customers unless the customer had an original meter resetting authorization letter as described in *Postal Bulletin 22072* (3-21-02, page 108). Unfortunately, errors occurred and some customers did not receive reset authorization letters. Many of those errors were brought to our attention as customers received follow-up letters.

When manufacturers were notified of a problem, they sent information to Postage Technology Management (PTM) requesting that new letters be issued; however, some customers needed immediate assistance. In order to minimize any disruption to those mailer's businesses, PTM sent an emergency e-mail message to the customer. The message authorized local postal employees to reset the meter(s), described by manufacturer, model, and serial number, for a specific date range that never exceeded seven (7) calendar days. After the expiration date, as

stated in the e-mail, the customer needs an original, valid authorization letter printed on the special security paper. The e-mail provided names and telephone numbers of Headquarters employees to contact in case of questions.

If customers do not have the original meter resetting authorization letter, please instruct them to contact their meter manufacturer at the corporate level, and not to contact their local meter representative. We published the appropriate contacts in *Postal Bulletin 22075* (5-2-02, page 132), *Postal Bulletin 22074* (4-18-02, page 110), and *Postal Bulletin 22073* (4-4-02, page 74–75). PTM will send an e-mail to customers if the manufacturer provides supporting justification.

— *Postage Technology Management,
Product Development, 5-16-02*

Postal Bulletin Distribution

The GPO distributes the *Postal Bulletin* for the Postal Service to all postal facilities except classified stations and branches, contract postal units, and detached mail units, which receive copies from their administrative post office. The *Postal Bulletin* is also available online at <http://www.usps.com> (click on *Info*, then *Postal Periodicals and Publications*).

If your postal facility has access to cc:Mail, you may send a request for a new subscription order, an address and/or quantity change, or a subscription query to the

cc:Mail address POSTAL BULLETIN. If you are using another email product, you can use the Internet email address pbulleti@email.usps.gov.

If you do not have access to email, you may complete the order form and mail it to:

ATTN POSTAL BULLETIN
 US POSTAL SERVICE
 475 L'ENFANT PLZ SW RM 5540
 WASHINGTON DC 20260-5540

Either way you send it, please include the "PO0" subscription number from your address label.

Postal Service Orders for Postal Bulletin

- New Order Change of Address/Quantity
(Include *Postal Bulletin* mailing label.)

Attention Line _____

Postal Facility Name _____

Delivery Address _____

City _____ State _____ ZIP+4 _____

Person to Contact
 () _____

Daytime Telephone _____

Current Quantity _____ New Quantity _____

Missing Issues: If postal facilities that receive the *Bulletin* from GPO do not receive their order, they should call the *Postal Bulletin* editor at 202-268-2836. All other facilities should contact their administrative post office.

Address and Quantity Changes and Subscription Problems: Postal facilities may send address and quantity changes and subscription queries via cc:Mail to POSTAL BULLETIN or via the Internet to pbulleti@email.usps.gov. Please include old and new address and quantities, and the "PO0" subscription number from your address label. Postal facilities may also complete this form and mail it to:

ATTN POSTAL BULLETIN
 US POSTAL SERVICE
 475 L'ENFANT PLZ SW RM 5540
 WASHINGTON DC 20260-5540

All other facilities should contact their administrative post office.

Single Copies (back to 1 year): To order extra copies or back issues (see Table of Contents for specific PSN), use MDC Touch Tone Order Entry by calling 800-332-0317 (option 1, then option 2) or send PS Form 7380, *MDC Supply Requisition*, to:

MATERIAL DISTRIBUTION CENTER
 ATTN SUPPLY REQUISITIONS
 500 SW GARY ORMSBY DR
 TOPEKA KS 66624-9702

Public Orders for Postal Bulletin

- New Order Change of Address
(Include *Postal Bulletin* mailing label.)

Attention Line _____

Company Name _____

Delivery Address _____

City _____ State _____ ZIP+4 _____
 ()

Daytime Telephone _____

Subscription: Domestic - \$155.00 per year; International - \$193.75 per year

Subscription Orders: 202-512-1800

Subscription Inquiries: 202-512-1806 Fax: 202-512-2250

Single Copies (back to 16 issues): Domestic - \$12.00; International - \$15.00

Enter _____ Annual Subscription(s).
 Total Amount \$ _____

Send _____ additional copies of *Bulletin* # _____
 Total Amount \$ _____

GPO deposit account [] [] [] [] [] [] [] [] - []

Check/money order payable to: Superintendent of Documents

VISA  MasterCard 

Credit Card Number _____ Expiration Date _____

Signature _____

Mail Completed Form and Payment To:
 SUPERINTENDENT OF DOCUMENTS
 US GOVERNMENT PRINTING OFFICE
 PO BOX 371954
 PITTSBURGH PA 15250-7954

**“Mom, why didn’t you wear
your work shoes?”**



**ALWAYS
WEAR PROPER
FOOTWEAR.**



 **UNITED STATES
POSTAL SERVICE**



475 L'ENFANT PLAZA SW
WASHINGTON DC 20260-5540

First-Class Mail
Postage & Fees Paid
USPS
Permit No. G-10

Thank you, postal employees!



Neither snow, nor rain, nor a nation challenged ...

Once again, we were challenged. And once again, we delivered for America.
The right stuff. We have it. We kept our commitment to universal service for every American.
No matter who, no matter where. It's what we do. Every day.
And I thank you for helping us do it.

— Jack Potter, Postmaster General